

PTEN

PROFESSIONAL TOOL & EQUIPMENT NEWS

\$15.00 • May 2023
Volume 34, Number 4

ENDEAVOR
BUSINESS MEDIA

TOOL BRIEFING

SERVICING TODAY'S
WHEELS AND TIRES
PAGE 26

CATEGORY SPOTLIGHT

SCAN TOOLS
PAGE 38

CARLYLE INSULATED HAND TOOLS

DESIGNED FOR ELECTRIC
VEHICLE TECHNICIANS



DETAILS ON THE COVER PRODUCTS
AND OTHER NEW TOOLS [PAGE 10](#)



▲ Displays remaining
charge time



▲ Reaches up
to 2,400 rpms



▲ Remote
monitoring
available

A powerhouse lineup of repair solutions from the global leader in diagnostics



Professional Diagnostics

The next generation of scan tools with the most advanced OE level vehicle coverage supporting scanning, live data access and complete bi-directional functions.

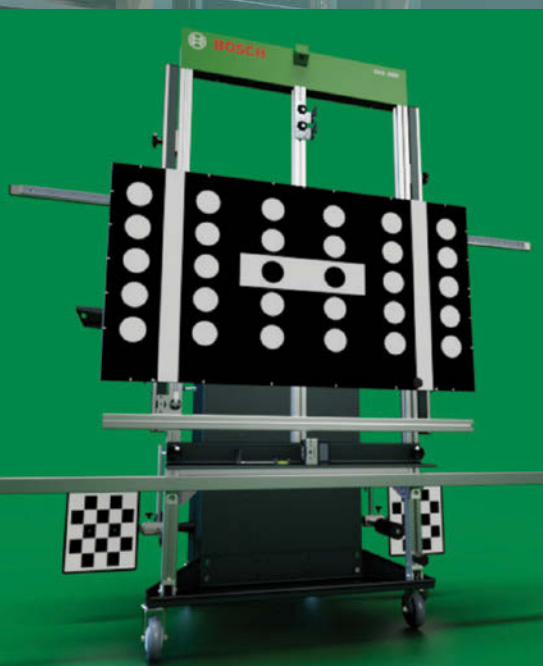

ADAS Recalibration

A seamless, full-system solution that guides you from setup through calibration in half the time.



Heavy Duty Diagnostics

Heavy duty solutions to help you get the repair done right and the vehicle back in operation.



Test, Tune and Analyze

Test, analyze and diagnose your vehicle electrical and mechanical systems.

FEEL THE CHILL

CONTROL YOUR CLIMATE. JUST ADD WATER.™

BEAT THE
HEAT
SALE
GOING ON NOW



LEARN MORE 



Bring Indoor Comfort Outdoors



26° F Cooling*



Easy-to-use Control Panel



Large Cooling Area



Auto-refill



Energy Efficient Warehouse Cooling

At Cool Boss, we focus on innovations that deliver incredible comfort and value. Every one of our COOLBREEZE™ and COOLBLAST™ evaporative coolers use tap water to instantly chill areas at a fraction of the cost of traditional air-cooling methods. Just plug them into a standard wall outlet, fill them with water, and instantly lower the surrounding temperature by as much as 26 degrees. It's that simple!

Learn more at COOLBOSS.COM or call 1-855-2BE-COOL

WWW.COOLBOSS.COM • 1-855-223-2665

©2023 BendPak Inc. All rights reserved. BendPak® is a registered trademark. *Your specific location may require a combination of multiple models and/or sizes to provide the most effective cooling experience.

Circle 2 on card or click "PTEN e-inquiry" on VehicleServicePros.com



A Division of BendPak Inc.

CONTENTS

Published by Endeavor Business Media, LLC

ENDEAVOR 30 Burton Hills Blvd, Ste 185
BUSINESS MEDIA Nashville, TN 37215
800-547-7377

Printed in the U.S. Volume 34, Number 4; May 2023

EXECUTIVE VICE PRESIDENT – TRANSPORTATION
Kylie Hirko 630-253-4034 Kylie@VehicleServicePros.com

VP/GROUP PUBLISHER, ENDEAVOR VEHICLE REPAIR GROUP
Chris Messer 651-206-3168 CMesser@EndeavorB2B.com

EDITOR Emily Markham
920-234-6359 Emily@VehicleServicePros.com

ASSOCIATE EDITOR Kayla Nadler
920-563-1764 Kayla@VehicleServicePros.com

ASSOCIATE SALES DIRECTOR Mattie Gorman-Greuel
920-563-1636 MGorman@EndeavorB2B.com

DIRECTOR OF BUSINESS DEVELOPMENT Cortni Jones
920-568-8391 CJones@EndeavorB2B.com

MULTIMEDIA ACCOUNT EXECUTIVE Diane Braden
920-568-8364 DBraden@EndeavorB2B.com

MULTIMEDIA ACCOUNT EXECUTIVE Lisa Mend
949-259-5654 LMend@EndeavorB2B.com

MULTIMEDIA ACCOUNT EXECUTIVE Michael Parra
925-307-8779 MParra@EndeavorB2B.com

MULTIMEDIA ACCOUNT EXECUTIVE Sean Thornton
269-449-0257 SThornton@EndeavorB2B.com

INSIDE SALES Mackenzie Verschoor
651-846-9472 MVerschoor@EndeavorB2B.com

PRODUCTION MANAGER Jane Pothlanski
224-324-8507 JPothlanski@EndeavorB2B.com

AD SERVICES MANAGER Carmen Seeber
920-568-8373 CSeeber@EndeavorB2B.com

ART DIRECTOR Tim Schafer

LIST RENTAL REP Michael Costantino
402-836-6266 Michael.Costantino@infogroup.com

LIST RENTAL REP Kevin Collopy
402-836-6265 Kevin.Collopy@infogroup.com

AUDIENCE DEVELOPMENT MANAGER Debbie Dumke

ENDEAVOR BUSINESS MEDIA, LLC

CEO – Chris Ferrell

President – June Griffin

CFO – Mark Zadell

COO – Patrick Rains

CRO – Reggie Lawrence

Chief Administrative and Legal Officer – Tracy Kane

EVP Marketing Solutions & Data – Jacquie Niemiec

Subscription Customer Service

877-382-9187; 847-559-759

Circ.ProfDistmag@omeda.com

PO Box 3257 • Northbrook IL 60065-3257

Article reprints reprints@endeavorb2b.com

Professional Tool & Equipment News (USPS 012-426, ISSN 1081-4485 print; ISSN 2150-2072) is published ten times a year in February, March, April, May, June, July, August, September, October, and December by Endeavor Business Media, LLC, 1233 Janesville Avenue, Fort Atkinson, WI 53538. Periodicals postage paid at Fort Atkinson, WI 53538 and additional mailing offices. POSTMASTER: Send address changes to *Professional Tool & Equipment News*, PO Box 3257, Northbrook, IL 60065-3257. Canada Post PM40612608. Return undeliverable Canadian addresses to: *Professional Tool & Equipment News*, PO Box 25542, London, ON N6C 6B2.

Subscriptions: Individual subscriptions are available without charge in the U.S. to qualified subscribers. Publisher reserves the right to reject non-qualified subscriptions. Subscription prices: U.S. \$50 per year, \$93 two year; Canada/Mexico \$72 per year, \$131 two year; All other countries \$105 per year, \$195 two year. All subscriptions payable in U.S. funds, drawn on U.S. bank. Canadian GST#842773848. Back issue \$10 prepaid, if available. Printed in the USA. Copyright 2022 Endeavor Business Media, LLC.

All rights reserved. No part of this publication may be reproduced or transmitted in any form or by any means, electronic or mechanical, including photocopy, recordings or any information storage or retrieval system, without permission from the publisher.

Endeavor Business Media, LLC does not assume and hereby disclaims any liability to any person or company for any loss or damage caused by errors or omissions in the material herein, regardless of whether such errors result from negligence, accident or any other cause whatsoever. The views and opinions in the articles herein are not to be taken as official expressions of the publishers, unless so stated. The publishers do not warrant, either expressly or by implication, the factual accuracy of the articles herein, nor do they so warrant any views or opinions offered by the authors of said articles.



34

ON OUR COVER

Insulated Hand Tools by Carlyle

Details on page 10



41

EXCLUSIVE

36 INNOVATION AWARDS PROFILE

We speak with Kent Automotive about their award-winning Torrent Parts Washer.

PRODUCTS

10 NEW PRODUCTS

Check out the latest offerings from AutoMeter, Martins Industries, Rotary, and more.

32 TOOL REVIEWS

Our review panel tests out four different tools and gives their feedback.

38 CATEGORY SPOTLIGHT

Scan Tools

COLUMNS

8 EDITOR'S NOTE

The future of the automotive industry

18 DIAGNOSTIC TECH

In this two-part series, Scott Brown starts off by taking an in-depth look at ADAS sensors.

26 TOOL BRIEFING

Ross Colket dives into tire and wheel service—providing proper service requires investing in the right equipment.

42 BIG-TIME BOXES

Tiffany Morgan, Midas in Troy, Michigan



42

AUTEL[®] MX-sensor 1 SENSOR

1 SKU SENSOR INVENTORY: 314.9MHZ, 315MHZ & 433MHZ

FAST INSTALLATION
PRESS RELEASE
INTERCHANGEABLE
VALVE STEMS



◀ ALUMINUM
RUBBER ▶

99% VEHICLE
COVERAGE
ORIGINAL EQUIPMENT
FIT FORM & FUNCTION



PROGRAMMABLE
UNIVERSAL TPMS



MAX SIGNAL
STRENGTH



**THE BEST SELLING
AFTERMARKET SENSOR**
IN NORTH AMERICA

COMPLETE
OE QUALITY SENSORS



SOLUTION
POWERFUL SCAN TOOLS



ITS600
TPMS DIAGNOSTICS & SERVICE

- Print/Email/Text TPMS Health Report
- OLS, BMS, SAS, EPB Service Resets
- **FREE** TPMS Updates for the Life of the Tool

TS508WF
TPMS SERVICE TOOL

- Perform OBDII Relearns
- Four 1-Sensor Programming Methods
- **FREE** Updates for the Life of the Tool



UPDATE
VIA WI-FI
NO PC
NEEDED

Circle 3 on card or click "PTEN e-inquiry" on VehicleServicePros.com

WEB: AUTEL.COM | SUPPORT: 1.855.288.3587
EMAIL: USSUPPORT@AUTEL.COM

FOLLOW US @AUTELTOOLS
f t o YouTube



AUTEL[®]

NOW ONLINE AT **VEHICLESERVICEPROS**.com

PHOTO GALLERY



The 2023 Equipment and Tool Institute (ETI) ToolTech event was held April 17-19 at the Hyatt Regency Tamaya in Santa Ana Pueblo, New Mexico. The event focuses solely on automotive related tool and equipment companies and the individuals at the forefront of the industry.
VehicleServicePros.com/53058342

TECHNICIAN PROFILE



Shortly after completing basic technician training from Universal Technical Institute, Brandon Ludwikowski was first hired as a porter, but it didn't take long for the shop owner to notice his strong work ethic and desire to learn. Today, Ludwikowski is the shop's senior Porsche technician.

VehicleServicePros.com/53026716

DIAGNOSTICS



Is your shop looking to upgrade its diagnostic tools and equipment? As Q1 comes to an end, here are the topmost clicked-on diagnostic tools and updates added to VehicleServicePros.com from 2023 so far.

VehicleServicePros.com/53056247

TECH TIPS



A customer brought in his 2002 Oldsmobile Bravada overheating and blowing white smoke. The water pump was locked up, so the technician replaced it, as well as the thermostat, radiator, and radiator cap. But on the test drive, the SUV started to overheat.

VehicleServicePros.com/53028378

TECH TRAINING



With the continual rise in the adoption of ADAS technology and the upcoming wave of EVs, technical training is not only an excellent tool to keep technicians and shops in the know of changing equipment and technology – but can act as an excellent tool in employee recruitment and retention.

VehicleServicePros.com/53042928

FEATURED PRODUCTS



CAT Footwear

Striver Steel Toe Work Boot

VehicleServicePros.com/53057121



Performance Tool

18-pc Brake Caliper Wind Back Kit, No. W89202

VehicleServicePros.com/53056957



Matco Tools

Maximus Diagnostic Thermal Imager

VehicleServicePros.com/53056849



ATD Tools

Exhaust Pipe Cutter Pliers, No. ATD-5721

VehicleServicePros.com/53057120



**EVERY TOOL
YOU NEED**

OEM TOOLS[®]
MADE FOR MECHANICS



- 37377: A/C Flush Kit
- 68989: R134a Professional A/C Kit
- 24609: Rechargeable Diagnostic Work Light
- 37150: A/C Clutch Hub Puller and Installer Set
- 25245: Infrared Thermometer

**ALL THE A/C REPAIR AND COOLANT TOOLS
YOU'LL EVER NEED FROM OEMTOOLS[®]**

Scan for Deals on OEMTOOLS A/C Repair and Coolant Tools or go to this link: BIT.LY/STAYCOOL



Circle 4 on card or click "PTEN e-inquiry" on VehicleServicePros.com



The future of the automotive industry

Some key takeaways from this year's ETI ToolTech conference.

By **Emily Markham**, Editor
EMarkham@EndeavorB2B.com

I'm sure it'll come as no surprise when I say the automotive industry is changing. Actually, according to Steve Greenfield, founder and CEO of Automotive Ventures, "The automotive industry is going to see more change in the next 10 years than it's experienced in the past 100."

Greenfield was the day one keynote speaker at this year's ETI (Equipment & Tool Institute) ToolTech conference. His presentation along with many others discussed some of the changes we can expect to see in the coming years.

1. Electric vehicles are coming

Over the past few years, we've seen many statements from vehicle manufacturers saying that by 2035 or so, they'll have a fully electric vehicle line-up. With all these new EV offerings on the way, Greenfield notes that EVs will overtake internal combustion engine (ICE) vehicles in less than 10 years. He cites a study done by S&P Global Mobility that predicts by 2027 EVs will overtake hybrid vehicles, by 2029 EVs will overtake ICE vehicles, and by 2032 EVs will overtake both hybrid and ICE vehicles.

More interesting though, was Greenfield discussing how EVs are less complex and need less maintenance than an ICE vehicle. Software updates will handle many vehicle "repairs" without the need for a technician to even touch the vehicle.

2. The impact of AI

AI has become an increasingly large part of all our everyday lives. But what impact does AI have in the automotive industry? More than you'd think if utilized in the right way.

Mark Seng, vice president of business development for Predii, discussed how AI can be used to "unlock your historical data." This means that when a vehicle comes into your shop, AI can look up records from similar vehicles with similar issues to give you an idea of what parts may need to be ordered or how to fix the vehicle based on past repairs. No person can remember everything, but with AI you won't have to.

3. Challenges in today's shops

The technician shortage remains one of the biggest challenges plaguing today's shops. Mike Allen, owner of Carfix Auto Repair & Tires in Raleigh, North Carolina, had

an interesting take on the root of the tech shortage, saying that the skilled labor shortage was created by the auto industry itself through not paying well enough or providing benefits. Future technicians are being lost to other industries, not other shops.

To counteract this issue and bring new workers into his shop, John Firm, owner of Firm Automotive in Fort Worth, Texas, notes he gets creative with pay and benefits, tries to stay connected with peers in the industry, and works with a business coach to stay up-to-date with industry trends. ❌

PTEN EDITORIAL ADVISORY BOARD

TECHNICIANS

ERIC MOORE,
DeMary Trucks, Columbus, OH
LOU FORT,
K.A.R.S. Inc., Huntingburg, IN

SHOP OWNERS

KIM AUERNHEIMER,
Cool Springs Automotive, Brentwood, TN
TANNER BRANDT,
Autodiag Clinic, Welford, SC
PHIL FOURNIER,
Phil's Auto Clinic, Hemet, CA
JD GOAD,
Goad's Body Shop, Lexington, VA
EDWIN HAZZARD,
Southeast Mobile Tech, Goose Creek, SC
PETE RUDLOFF,
Pete's Garage Inc., Newark, DE
MICHELLE TANSEY,
Dubclinic, Santa Clara, CA

EQUIPMENT MANUFACTURERS

KIMBERLY COTTE
Associated Equipment
JIM O'HARA,
Clore Automotive



FACEBOOK
facebook.com/
ptenmagazine



LINKEDIN
linkedin.com/company/
professional-equipment-tool-news



INSTAGRAM
@ptenmagazine



YOUTUBE
PTEN (Professional Tool
& Equipment News)



RCCS3

DIGITAL INNOVATION

LASER ACCURATE ADAS CALIBRATION &
HD 4K Target Representation That Meets OE Specification



BLUETOOTH LASER

DISTANCE MEASURE

ACCURATE CENTERING & SQUARING
OF CALIBRATION FRAME TO VEHICLE

75" MONITOR 4K

HD TARGET DISPLAY

AUTOMATIC VEHICLE TARGET SELECTION
DOES NOT DEFORM OR RESIZE TARGETS
SOFTWARE UPDATES NEW PATTERNS

VIRTUAL POSITIONING

GUIDED PROCEDURE

IDC5 SOFTWARE CONFIRMS STEP-BY-STEP
BLUETOOTH LASER DISTANCE MEASURE &
CALIBRATION FRAME MICRO ADJUSTMENTS

DIAG REPORT

POSTSCAN
CALIBRATION
ACCURACY

Circle 5 on card or click "PTEN e-inquiry" on VehicleServicePros.com

409 JOYCE KILMER AVENUE
NEW BRUNSWICK, NJ 08901

NORTHAMERICA@TEXA.COM

WWW.TEXAUSA.COM



FEATURED NEW PRODUCTS



CHARGES BATTERY PACKS OF UP TO EIGHT BATTERIES AT ONCE

The **AutoMeter Fully Automatic Heavy Duty Smart Charger**, No. BPC-100, features a switching power supply design that allows for high-efficiency charging of a single battery or battery packs of up to eight batteries at once without the need to separate the pack. With fast charge and full charge options, users can safely charge both standard/flooded and AGM batteries. The BPC-100 can accept input voltages ranging from 100V to 240V AC and has a charging output of up to 100A. The counter feature displaying remaining charge time and automatic shut off facilitate optimal utilization of shop labor. It includes a carrying handle, two gauge cables with heavy duty clamps, and an audible charge completion alert.

Circle 6 on card or click "PTEN e-inquiry" on VehicleServicePros.com

MAXIMUM SPEED OF 2,400 RPMS

The **Martins Industries Impulse 1/2" Cordless Impact Wrench**, No. MX-P1, features a maximum breakaway torque of 796.6 ft.-lbs for a maximum speed of up to 2,400, 1,900, and 1,500 rpms. The MX-P1 utilizes a forward/reverse button and a three-speed push button switch to easily increase speeds for optimal mounting. It has a built-in LED worklight and an ergonomic handle for comfort. With a brushless motor, the impact wrench provides ideal performance with less maintenance. The tool is operated by a 21V - 4000 mAh Li-ion battery and comes with a charger and an additional battery.

Circle 7 on card or click "PTEN e-inquiry" on VehicleServicePros.com



AVAILABLE IN THREE MODELS

The **Rotary R3AC Series A/C Recharging Machines** are designed to automatically service the refrigerant in vehicle air conditioning systems. The product line provides professionals with a quick, efficient, and cost-effective way to recover, recycle, and recharge R-134a and R-1234yf refrigerant gases. Powered by TEXA, the A/C machines are available in three models: single-gas R3AC50-A (R-134a compatible), single-gas R3AC60-YF (R-1234yf compatible), and dual-gas R3AC80-AYF (both R-134a and R-1234yf compatible). Each machine is Wi-Fi enabled, updates automatically, and can connect to peripheral devices, such as smartphones and printers. Remote monitoring is also available through a mobile app.

Circle 8 on card or click "PTEN e-inquiry" on VehicleServicePros.com



FOR MORE INFORMATION ON THESE PRODUCTS, CLICK ON "PTEN E-INQUIRY" at VehicleServicePros.com OR CIRCLE THE NUMBER ON THE CARD.

Kicking off the New Products section each May, our Featured New Products page includes brand new products showcased on the cover that are available to the automotive market.



DESIGNED FOR EV TECHNICIANS

The **Carlyle Insulated Hand Tools** range has been developed specifically for electric vehicle service in the automotive aftermarket and offers a full line of tools. Every Carlyle Insulated Hand Tool is individually tested and certified to meet VDE, GS, IEC60900, and ASTM F1505 standards and rated to 1,000V AC/DC. Simply put, these tools are designed to minimize the threat of severe injury to technicians, to prevent damage to customers' cars, and to mitigate the risk of fire inside the repair shops and garages. The Carlyle Insulated Hand Tools carry the same lifetime warranty as all Carlyle hand tools do.

Circle 9 on card or click "PTEN e-inquiry" on VehicleServicePros.com

SPONSORED BY CARLYLE TOOLS



DURABLE STAINLESS-STEEL WORKSPACE

The **Homak Manufacturing 44 RS Pro 9-Drawer Power Service Cart** features an electric-powered tool drawer with slotted slides to efficiently store, organize, and charge power tools in one place. The top till includes a lockable security compartment with an additional electric outlet to store laptops, phones, or other electronics. The heavy duty rubber-coated steel push handle allows the product to maneuver easily around the shop, and the lift latch drawer pulls prevent drawers from accidentally opening. Each drawer is fully extendable, can hold up to 100 lbs, and is lined with PVC foam. A high gloss UV protective powder coat finish prevents rusting.

Circle 10 on card or click "PTEN e-inquiry" on VehicleServicePros.com



IMPROVED WEAR AND TEAR ENHANCEMENTS

The **Danmar Updated Swing-Arm Tire Changers**, Nos. DT-50 and DT-50A, now include enhancements to improve wear and tear. The bead breaker blade received a rubber bump-stop to ensure a smooth arm return, reducing shock loading. The stainless steel and aluminum pneumatic cylinders received internal end-of-stroke cushions that protect the seals, wear band, and piston rod. Both tire changers feature a swing-arm design that facilitates quick loading, with steel clamps to efficiently handle 12" to 26" wheels, including low-profile and run-flat beads. For stiff sidewalls, the DT-50A adds a power-assist tower. The Danmar tire changers' high-torque turntable with reverse-direction control enables fast tire swaps.

Circle 11 on card or click "PTEN e-inquiry" on VehicleServicePros.com



STRAIGHTENS TUBING UP TO 3/8"

The **AGS EZ Fit Adjustable Tubing Straightener** is designed to straighten tubing including NiCopp, copper, aluminum, stainless steel, and plastics up to 3/8" in diameter. It can be used by hand or in a vice. It also has a wheel, allowing users to run it along a workbench or floor surface. Constructed of a corrosion-resistant plated steel body and eight stainless-steel rollers with nylon bearings to ensure smooth tube rolling. The adjustable open side entrance allows users to straighten lines that are already flared. Simply open the jaws, insert the line, use the hand lever to adjust to the tube diameter, and squeeze the handle.

Circle 12 on card or click "PTEN e-inquiry" on VehicleServicePros.com

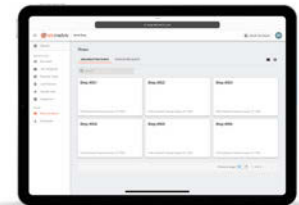

PROVIDES REAL-TIME DATA REPORTS

Tekmetric Multi-Shop offers auto repair shops access to real-time data reports from all locations in a central reporting suite. The plan provides shop owners the tools to monitor shop performance across all locations through key features, such as custom shop comparison, organization-level reports, centralized data management, and employee tracking capabilities. Shop owners can track real-time metrics in one location and access analysis at all organizational levels. Additionally, the plan offers a custom side-by-side report, so shop owners can drive key business decisions and replicate processes from high-performing shops.

Circle 14 on card or click "PTEN e-inquiry" on VehicleServicePros.com

DOES NOT USE ANY SLIDING PARTS

The **ARI-Hetra Heavy-Duty Platform Lifts (HDPL)** do not use any sliding parts thanks to their unique geometric configuration. Not only does this avoid wear on wheels or slide blocks but also eliminates the need for lubrication. Their maintenance-free joints are also designed to reduce machine downtime and there are no structural elements between lifting platforms, providing maximum accessibility in the working area. The lifts feature a mechanical locking device with automatic engagement and pneumatic release on each piston as well as electronic sensors that synchronize the pistons with auto-leveling and independent load distribution. Additionally, with an electronic control system and LCD screen, height per leg and the adjustable maximum height limit are displayed.



Circle 13 on card or click "PTEN e-inquiry" on VehicleServicePros.com



PRYBARS CAN ATTACH HORIZONTALLY OR VERTICALLY

The **Snap-on Flexible Magnetic Prybar Holder**, No. FLEXPBARHLDR, helps ease work for technicians by saving on space and keeping tools close-by but safely out of the way. The prybar holder is made of non-marring silicone polymer and features front magnets to allow attachment of pry-bars either horizontally or vertically and a modular, interlocking design for multiple prybar holders to be connected. Rear magnets secure the holder to the user's toolbox or other metallic surfaces while their pull tabs make removing easy and damage free.

Circle 15 on card or click "PTEN e-inquiry" on VehicleServicePros.com



AVAILABLE IN TWO SIZES

The **Portasol-Patch** from **Portasol** is an instant, multi-purpose repair patch available in two sizes: 3" by 6" and 6" by 9". It's easy to use, is self-adhesive, and is a long-lasting solution for a wide variety of applications, including automotive repairs from bumpers, radiators, exhaust leaks, fuel tanks and lines, headlights, and more. The Portasol-Patch is a durable fiberglass-reinforced polyester that can be sanded, grinded, drilled, tapped, and painted. It's waterproof, weather-proof, rot, rust, fire and impact-proof, while also being chemical and temperature resistant from -40 to 392 degrees F. The non-toxic patch will work on almost any hard surface and will not shrink or expand during application, or when cured.

Circle 18 on card or click "PTEN e-inquiry" on VehicleServicePros.com



DISPLAYS OVER 40 MESSAGES DURING DIAGNOSTIC OPERATIONS

The **TEXA TXT Multihub** is a VCI designed to easily adapt to any vehicle connection in the shop or in the field. It features a built-in backlit display to visually confirm connection status, new protocols (including RP1210 for heavy duty vehicles) and connection options for versatile modular vehicle diagnostics, a standalone Linux operating system for adaptable vehicle connection and greater security, as well as new certified durability for rugged environment use. The TXT Multihub confirms constant control by displaying more than 40 messages during diagnostic operations, like connection status as standard, Wi-Fi, DoIP ethernet, and Pass-Thru.

Circle 16 on card or click "PTEN e-inquiry" on VehicleServicePros.com



WEIGHING IN AT JUST 5.11 LBS

The **Getac Technology Corporation B360 and B360 Pro Fully Rugged Laptops** are designed to deliver connectivity, reliability, and computing performance to professionals working in challenging environments. Key features include an upgraded Intel Core 12th generation i5/i7 processor with integrated Intel Iris Xe graphics, an upgraded USB 3.2 port, a Thunderbolt 4 Type-C port, an upgraded HDMI 2.0 port, as well as the addition of a mini-SIM card slot. The B360 Pro takes it even further, with optional NVIDIA GeForce GTX1650 4GB discrete graphics controller, plus an optional media bay that can accommodate a third SATA SSD (for up to 6TB storage capacity), third battery, or a DVD drive as required. Both laptops weigh just 5.11 lbs.

Circle 17 on card or click "PTEN e-inquiry" on VehicleServicePros.com

COMPATIBLE WITH ALL DEWALT 20V MAX TOOLS

The **DeWalt POWERSTACK 20V Max 5Ah Compact Battery** is lightweight, weighing in at 1.5 lbs, to provide tool maneuverability, high precision, and reduced fatigue when used in tight workspaces. It features an impact-resistant, rubber over molded base and includes a charge indicator with three LEDs. The POWERSTACK 20V Max 5Ah Compact Battery offers 50 percent more power than DeWalt's previous 20V Max 5Ah Battery (DCB205). Battery is compatible to work with all DeWalt 20V Max tools and chargers.



Circle 19 on card or click "PTEN e-inquiry" on VehicleServicePros.com

FEATURES A PATENTED SPIRAL-FLUTED STEPPED-TIP DESIGN

The **Astro Tools ONYX 29-pc TurboStep HSS Reduced Shank Mechanics Length Drill Bit Set**, No. TS29, features a patented spiral-fluted stepped-tip design that outperforms every conventional drill bit design on nearly all materials, says the company. These drill bits range in size from 1/16" - 1/2" and are precision ground from heat-treated quality M2 high-speed steel. They are also onyx oxide coated to prevent chip build-up. The design eliminates bit walk and saves time, eliminating the need for pilot holes. They also feature three-flat shanks, reduced shanks above 3/8", and are mechanic's length in order to access cramped spaces. They excel on hard alloys, sheet metal, and imperfect parts that are difficult to start drilling into.

Circle 20 on card or click "PTEN e-inquiry" on VehicleServicePros.com





FOR MORE INFORMATION ON THESE PRODUCTS,
CLICK ON "PTEN E-INQUIRY"
at VehicleServicePros.com
OR CIRCLE THE NUMBER ON THE CARD.

NEW PRODUCTS 



HAS A LIFTING RANGE FROM 3" TO 21"

The **OTC 2-Ton Low Profile Long Reach Service Jack**, No. LDJ2, is ideal for general service and high-volume service shops looking to lift midsize cars, trucks, SUVs, and compact cars and SUVs. The safety-tested design provides lifting with an extended reach to accommodate OE lifting points, and a low profile for vehicles with low-to-ground aerodynamic treatments. The LDJ2 has a lifting range from 3" to 21", a reach of 69", four casters (two front fixed, two rear swivel), a frame height of 2.75", and a 4" diameter round rubberized saddle. The handle measures 50" in length.

Circle 21 on card or click "PTEN e-inquiry" on VehicleServicePros.com



PERFORMS EV BATTERY PACK ANALYSIS

The **Autel EV Diagnostics Upgrade Kit** adds EV and hybrid vehicle diagnostics without the need of having to purchase a new tablet. It performs a state of charge and state of health analysis for true battery condition. The kit includes the EVDiag Box, testing software, and adapters for specific EVs to enable testing of battery packs. The Upgrade Kit connects with existing MaxiFlash VCI or VCMI, and is compatible with the MaxiSYS Ultra, Ultra ADAS, MS919, and MS909.

Circle 22 on card or click "PTEN e-inquiry" on VehicleServicePros.com



Watch this product in action here:
VehicleServicePros.com/53056737



PUSH BUTTON FOR EASY ADJUSTMENTS

Designed to meet the ever-changing demands of America's trades pros, **Channellock SpeedGrip Tongue & Groove Pliers** combine the dependability of the company's original Tongue & Groove Pliers with an innovative push button for fast and easy adjustments that lock into place. Forged from high-carbon U.S. steel and featuring laser heat-treated crosshatch teeth, SpeedGrip Pliers are built for maximum strength and grip 2.5 times better than traditional tongue and groove-style pliers, says the company.

Circle 23 on card or click "PTEN e-inquiry" on VehicleServicePros.com

STREAMLIGHT
BEARTRAP[®]

The Ultra-Positionable Worklight.

When your job takes you to some dark places, reach for the powerful BearTrap[®]. No matter where you go, you can clamp it, hang it or stand it and keep it charging while you're working. Light your way all day and know you won't leave any scratches behind.

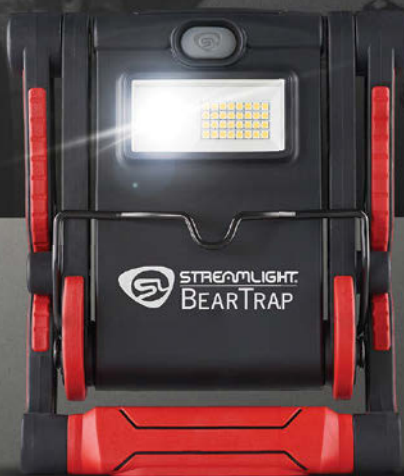

2,000 LUMENS

CLAMPS VIRTUALLY ANYWHERE

SPOT/FLOOD

RECHARGEABLE



[STREAMLIGHT.COM/BEARTRAP](https://Streamlight.com/BearTrap)

© 2022 STREAMLIGHT, INC. ALL RIGHTS RESERVED.

STREAMLIGHT
50 YEAR
ANNIVERSARY
SINCE 1973

Circle 24 on card or click "PTEN e-inquiry" on VehicleServicePros.com

NEW PRODUCTS



WORKS IN TIGHT SPOTS

The **Lisle Corporation Electrical Disconnect Pliers**, No. 37960, are designed to easily remove locking push tab style electrical connectors found on mass air flow sensors, fuel injectors, ignition coils, and other applications. Simply use the hook on the end of the pliers to pull the tab out to unlock and then use the point to engage the tab. Squeeze the tabs together and lift to separate the connector from sensor without damage. The pliers allow technicians to use the tool with one hand, and to work on sensors in tight spots. The tool measures 8" in length and has dual durometer grips for comfort.

Circle 25 on card or click "PTEN e-inquiry" on VehicleServicePros.com



Watch this product in action here:
VehicleServicePros.com/53042202



BUILT-IN HUMAN BODY SENSOR

The **SABER 2,000 Lumen LED Corded/Cordless Underhood Light**, No. ATD-80365, features a human body sensor (HBS), which is a 360-degree microwave radar sensor that automatically activates the light when a human body is within 10' to 15' and turns off when out of range. The sensor saves on both battery power and lifecycle. The 40" light bar emits up to 2,000 lm, offers two modes (high and low), and has large, padded covered hooks that extend from 55" to 83", capable of fitting new SUVs and light trucks. The light comes with a 25' removeable cord that remains flexible in cold weather and is oil and grease resistant.

Circle 28 on card or click "PTEN e-inquiry" on VehicleServicePros.com



REMOVES DAMAGED AND FROZEN FASTENERS

The **ARES Tool 18-pc Combo Turbo Socket Set**, No. 29022, comes with 16 1/4" drive turbo sockets with SAE and metric size markings, a 1/4" drive hex adapter, a knockout pin, and a storage case. Socket sizes include 3/16", 7/32", 1/4", 9/32", 5/16", 11/32", 3/8", 4.5mm, 5mm, 5.5mm, 6mm, 6.5mm, 7mm, 7.5mm, 8mm, 8.5mm, 9mm, 9.5mm, and 10mm. Made of premium hardened steel, the impact grade turbo sockets feature a helical teeth design that offers a secure grip and reduces slippage when removing damaged, tapered, rounded, or frozen fasteners. The set is ideal for automotive repair involving rusted and damaged fasteners, and small engine care.

Circle 26 on card or click "PTEN e-inquiry" on VehicleServicePros.com



HAS BUILT-IN OBD-II

The **Matco Tools Maximus TPMS 3.0 Diagnostic Tool**, No. MDMAXTPMS3G, provides functions like suspension diagnostics, fuel economy, oil life, and more. The pocket-sized TPMS tool features an icon-based touchscreen, one-touch wireless Wi-Fi updates, built-in OBD-II, and a customizable background color interface. Additionally, it's able to read all vehicles equipped with TPMS through 2022, offers upgrades and software updates, and keeps customer records including stored history and record storage.

Circle 29 on card or click "PTEN e-inquiry" on VehicleServicePros.com



5 DEGREE INCREMENTAL MOVEMENT

The **Mac Tools SAE and Metric XL Fixed/Flex Head Ratcheting Wrench Sets**, Nos. SRDBL1012PT and SRDBL1212PT, feature a fixed, 12-pt zero degree offset for straight-on access to remove fasteners and for high torque as well as a 12-pt ring end that is flexible through 180 degrees. The ratcheting side also has a 72-tooth gear design for 5 degree incremental movement. The ratcheting side also has a 72-tooth gear design for 5 degree incremental movement. The ring profile is designed to maximize contact surface with the nut for a longer lifetime. Available in two sets: 10-pc SAE XL Fixed/Flex Head Ratcheting Wrench Set (No. SRDBL1012PT) and 12-pc Metric XL Fixed/Flex Head Ratcheting Wrench Set (No. SRDBL1212PT). The SAE set includes sizes 5/16" to 7/8". The metric set includes sizes 8mm to 19mm.

Circle 27 on card or click "PTEN e-inquiry" on VehicleServicePros.com

CAN ALSO MEASURE RESISTANCE UP TO 5K OHMS

The **12V/24V Sensor Voltage Probe** by **Prologics** can emulate signals generated by different types of sensors in a vehicle. Simply set the output voltage to the correct value and activate it with either 3A or 150mA on a permanent output or with a switch. Whether checking the component independently or using a diagnostic scanner, this voltage probe is designed to make it easy to identify if the fault lies in the sensor or its connection. The Sensor Voltage Probe can also be used to measure resistance up to 5K Ohms.

Circle 30 on card or click "PTEN e-inquiry" on VehicleServicePros.com





FOR MORE INFORMATION ON THESE PRODUCTS,
CLICK ON "PTEN E-INQUIRY"
at VehicleServicePros.com
OR CIRCLE THE NUMBER ON THE CARD.

NEW PRODUCTS



ERGONOMIC, TWO-COMPONENT HANDLE

The **Mueller-Kueps Mini Pry Bar Set**, No. 276 100, is a universal use set ideal for any application that requires lifting or prying. The pry bars have a black oxide finish to help protect the tools against corrosion, are made from hardened and tempered steel to provide maximum durability, and feature a six-sided shaft for strength. With an ergonomic, two-component handle, the pry bars offer a comfortable and secure grip through all applications. The set includes two different tip widths and an angled design to give the user maximum leverage and options.

Circle 31 on card or click "PTEN e-inquiry" on VehicleServicePros.com



SHATTER-RESISTANT POLYCARBONATE LENSES

The **Coxreels Industrial Duty LED Lights for PC10 Series** feature a 50,000 hour rating, internal light diffusers, and shatter-resistant polycarbonate lenses. Designed for PC10 Series reels, the LED lights are available in three models to compliment a variety of applications and include adjustable steel hooks for handsfree placement. The line includes: a compact LED (-M), an LED with additional power source (-K), and an industrial-duty, UL-listed LED (-H).

Circle 32 on card or click "PTEN e-inquiry" on VehicleServicePros.com



SAFELY RELEASES ROOF PANELS

The **CTA Manufacturing 2-pc VW Roof Grab Release Tool Kit**, No. 3033, is designed to help Volkswagen technicians easily and safely release the roof panels. The kit includes CTA's VW Roof Grab Release Tool (v2), No.1464, and VW Roof Grab Release Tool (v1), No. 8061. These tools are specifically designed to fit Volkswagen vehicles and are made with high-quality materials to ensure durability. The v2 tool features an updated design with a different angle and shank dimensions, as well as a more secure grip. The tool is also made with hardened steel for added strength and durability.

Circle 33 on card or click "PTEN e-inquiry" on VehicleServicePros.com

Beta

Italian design. European quality.

1148

AUTOMATIC WIRE STRIPPER

The **Beta 1148** wire strippers automatically adjust to the conductor type: stranded or solid. The integrated wire cutter and wire stop adjust for precision insulation removal. The unique design incorporates a fine adjustment without damaging the conductor and stripping blade replacement to ensure quality and performance.

1148A-Series SAE/Metric 34 to 8 AWG

Cutting capacity:
10 Mm² (8 AWG) flexible wires
1,5 Mm² (16 AWG) wires



1148B-Series SAE/Metric 12 to 6 AWG

Cutting capacity:
10 Mm² (8 AWG) flexible wires
1,5 Mm² (16 AWG) wires



#011480100



#011480202

betatoolsusa.com

1.717.449.5044

Beta Tools USA is a subsidiary of BETA UTENSILI S.P.A. Sovico (MB) - Italy

Circle 34 on card or click "PTEN e-inquiry" on VehicleServicePros.com



PROTECTS AGAINST CRACKLING OR SHREDDING

The **Milwaukee Tool SHOCKWAVE Impact Duty 1/2 Drive Lug Nut Wheel Sockets** are designed for tire installations and removals. The sockets feature a durable, non-marring sleeve to protect rims during tire changes while ensuring the durability of the sleeve. With this Armor-Guard sleeve, each socket protects against crackling or shredding. The lasting-protection sleeves are color-coded gray and red to distinguish between metric and SAE sizing and include stamped, ink-filled markings on the socket for easy size identification. The sockets also have a plastic insert, preventing the lug nut from marring while being used. Constructed with thin walls, the sockets are optimized for users to access the tight spaces around lug nuts.

Circle 35 on card or click "PTEN e-inquiry" on VehicleServicePros.com



IDEAL FOR WORKING IN INTRICATE SPACES

The **Ingersoll Rand 320PG Pencil Grinder** features a slim profile, making it ideal for working in intricate spaces. Created with a molded custom TPU grip for easy handling and an oversized speed control knob, the 320PG provides maximum comfort for extended use. Ideal for jobs from precise grinding, to final cleaning and polishing dies, to mold finishing, light deburring, and flash removal.

Circle 38 on card or click "PTEN e-inquiry" on VehicleServicePros.com



OFFERS THREE-POSITION RATCHETING TEMPLES

The **Thraxus Elite Safety Eyewear** from **Radians** are available with or without IQuity, Radians' intelligent anti-scratch, anti-fog technology. The Elite eyewear are engineered with the same patented edge design and cyclonic venting of the original high-performance Thraxus safety glasses. To provide a custom fit on a variety of head shapes and sizes, Elite also features three-position ratcheting temples with a wire core that allows for more adjustability. A soft brow further boosts the comfort level. Thraxus Elite IQuity incorporates even more features to offer ANSI Z87.1+ high impact protection, D4 dust and D3 liquid splash protection, as well as X anti-fog performance.

Circle 36 on card or click "PTEN e-inquiry" on VehicleServicePros.com



VERSATILE CLAMPING HANDLE

The **Streamlight Vulcan Clutch Lantern** is a multi-function, rechargeable lantern that features a swivel neck and a 340-degree rotating head. The light includes a versatile clamping handle, enabling users to attach it virtually anywhere to provide light in multiple directions. The lantern uses three white high-power LEDs for brightness. On high, it delivers 1,700 lm and 67,500 candelas over 520m; on low it offers 380 lm and 15,000 candelas over a 245m beam distance. Run-times are 6.5 hours on high and 18 hours on low. The Vulcan Clutch is waterproof, impact resistant, and available in safety orange and safety yellow.

Circle 39 on card or click "PTEN e-inquiry" on VehicleServicePros.com



AVAILABLE IN VARIOUS COLORS

The **Cornwell Quality Tools ARCA Tool Storage** lineup consists of a 57" 8-Drawer Double Bank Roller Cabinet and a 79" 13-Drawer Triple Bank Roller Cabinet, along with canopies and lockers. The ARCA tool storage features dual roll cage construction, Accuride drawer slides, a lock mechanism, 6" by 2" glass-reinforced casters, and a textured mid-gloss finish. The drawer slides operate well under load and reduce drawer droop when the drawer is at full extension. Latching also works well even if the box is on an uneven floor. Available in various colors: ignition orange, lighting yellow, torch blue, vapor, smoke, storm, and shadow.

Circle 37 on card or click "PTEN e-inquiry" on VehicleServicePros.com

PORTABLE AND EASY TO USE

The WD-40 Specialist Degreaser and Cleaner

EZ-Pods are ideal for greasy wheels, gears, floors, and surfaces, including concrete and stainless steel. Made from a concentrated, industrial-strength formula, the pods are portable, easy to store, and easy to use. Simply drop one EZ-Pod in 32 oz of water for a ready to mix-and-go solution that dissolves in minutes. The pods work in any temperature water but dissolve best in warm water and can be used in a variety of applications like spray bottles, buckets, and power washers. The EZ-Pods can be used on sensitive surfaces like plastics, rubber, neoprene, carbon fiber, copper, aluminum, chrome, and painted areas.

Circle 40 on card or click "PTEN e-inquiry" on VehicleServicePros.com



REV UP YOUR SAVINGS!



ALL-IN-1 SHOPPING



Call Now for a **FREE** catalog!

1-800-261-7729

Ask about our price promise guarantee.

WRENCHERS.com

© 2023 Wrenchers LLC. All Rights Reserved.

Circle 41 on card or click "PTEN e-inquiry" on VehicleServicePros.com

Sensors for current and future vehicle systems: **Understanding ADAS sensors, part 1**

Diving into the technology behind cameras, lidar, infrared cameras, radar sensors, acoustic sensors, and others used in advanced driver assistance systems.

By Scott Brown, Technical Editor

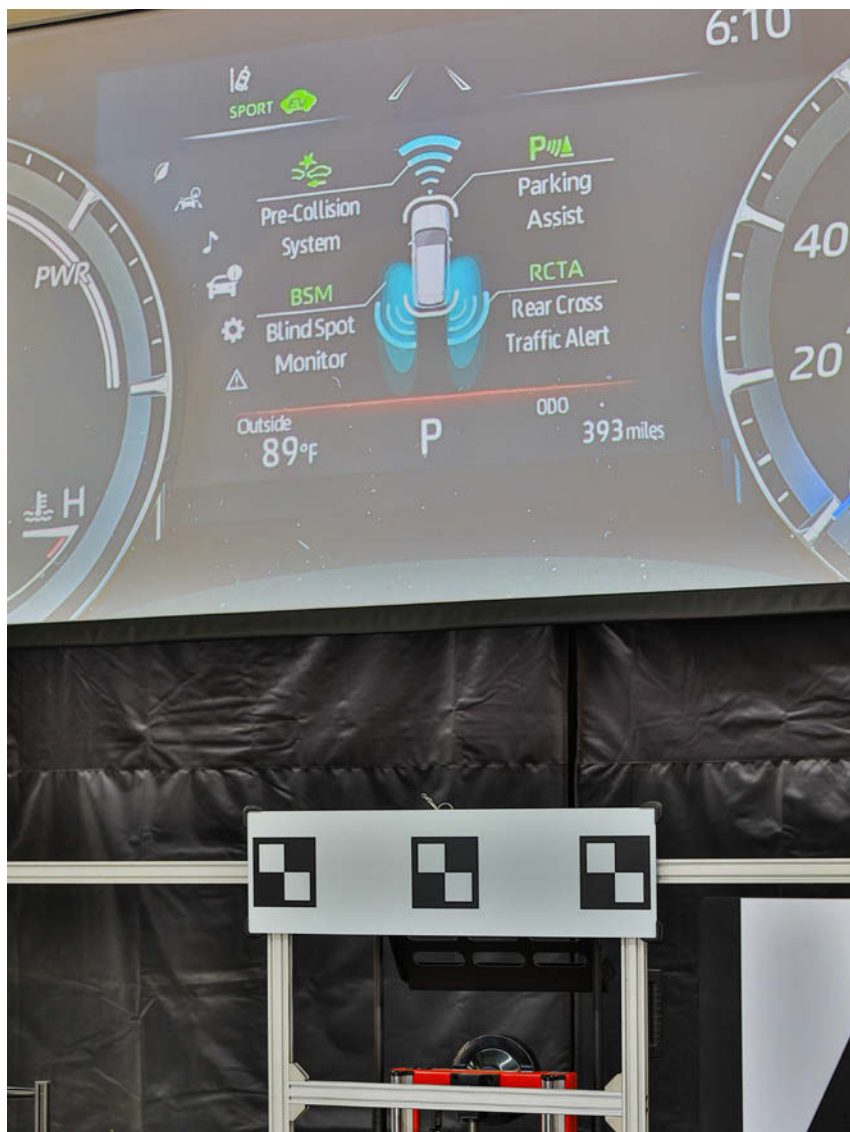

Today's advanced driver assistance systems (ADAS) are supported by various sensors and are paving the way toward future automation in next-generation vehicles.

The advanced driver assistance systems (ADAS) of today are supported by various sensors and are paving the way toward future automation in next-generation vehicles. You've likely encountered these systems where service operations required you to perform additional operations to maintain system integrity to support proper operation. These sensors could include cameras, infrared cameras, lidar (light, detection, and ranging), radar, and ultrasonic sensors. In this two-part article, we will take a closer look at different types of ADAS sensors and discuss how they are used to support ADAS and ultimately, SAE J3016 Level-5, fully autonomous vehicles.

CAMERAS

For at least the last decade we've seen most manufacturers deploy forward-facing cameras on some of their vehicles. The very early systems classified as SAE J3016 Level-0, mainly provided warnings for lane departure and potential collision events with vulnerable road users (VRUs). As computer vision (CV) technology advanced, ADAS became far more capable. CV and artificial 

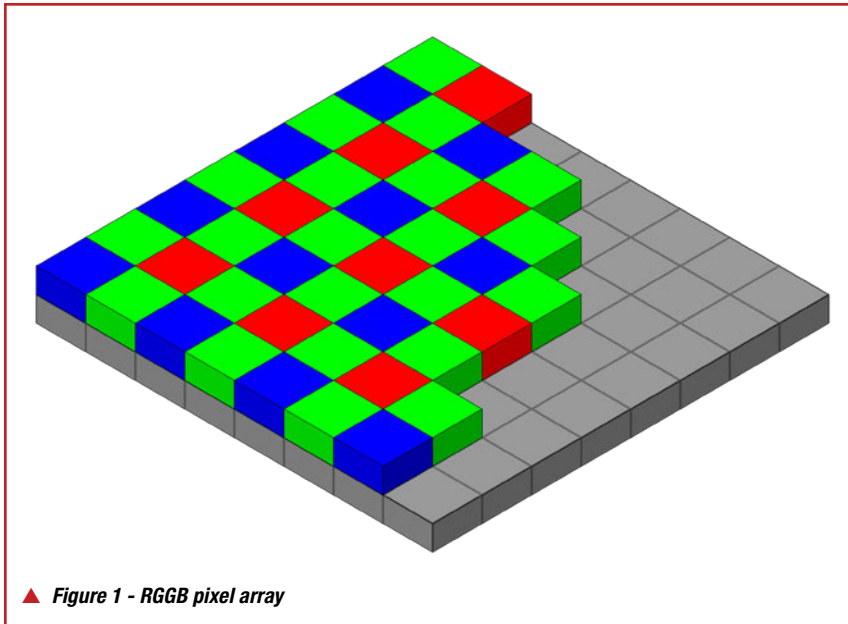

▲ Figure 1 - RGGB pixel array

intelligence (AI) brought forward artificial neural networks (ANNs) capable of identifying the environment around the vehicle with object detection, classification, body pose detection, semantic segmentation, character recognition, and more, typically based upon industry standard “common objects in context” (COCO) datasets used for training perception networks.

DIGITAL CAMERA BASICS

A digital camera collects the light rays reflected from objects within the camera’s field of view (FOV) which are passed through a series of concave and convex glass elements that make up the lens. Light rays passing through each layer are deformed in a way so that they are translated onto a flat plane. The flat plane hosts the digital sensor made up of receptor pixels. The light is first passed to the receptors via an array of red, green, and blue filters which are arranged in an out-of-balanced manner where 25 percent are red, 25 percent are blue, and 50 percent are green (Figure 1). Red, green, and blue are typically the primary colors used in digital photography because they are additive colors and the mix of adding these together at various levels allows for the closest

reproduction of the images for display.

If the imager has a resolution of 1920x1080, there would be an array of color receptors in the arrangement of about 500,000 red and blue filters and about 1.5 million green filters. From there, each pixel “borrows” the color information from each adjacent color receptor to fill in the other colors. This process is referred to as “bayering.”

The lens elements help to capture the desired field of view (FOV) by the design engineer. This could be an extremely wide area such as required by a single backup camera sweeping up to 180 degrees (Figure 2). This can be classified as the extreme where straight lines are clearly distorted. This is where one level of calibration comes into play which we’ll go into later in the calibration section of this article.

For automotive use, cameras are typically designed differently by eliminating the green filters and replacing them with clear ones. You may see this denoted as RCCB. The reason for this is that the clear pixels allow for better low-light sensitivity and lower noise because the sensor gain doesn’t have to increase as much in such conditions. CV supporting ADAS doesn’t need to see pretty pictures, they just need the

AIRCAT
PNEUMATIC TOOLS®

TOOL LINEUP

SPECIALTY TOOLS

6350 6355-A 6390



SANDERS

6320 6700-6-336 6315-K



GRINDERS

6260 6265 6340-A



CUT-OFF TOOLS

6505 6525-A 6275-A



HAMMERS

5250-A-T 5300-B-T



instagram.com/aircatusa/

facebook.com/aircat.pneumatictools/



AIRCAT.COM

(888) 4-AIRCAT

Circle 42 on card or click “PTEN e-inquiry”
on VehicleServicePros.com



▲ **Figure 2 - Wide-angle back-up camera**



▲ **Figure 3 - Lidar sensor**

appropriate information leading to superior perception of the environment around the vehicle.

TOF CAMERAS — LIDAR

Time of flight (ToF) cameras typically work by emitting light pulses, typically in the infrared (IR) spectrum which we humans cannot see without special instruments, (see my video covering lidar here: youtu.be/K7NRdwpqaAI) and measuring the time it takes for the light to reflect from an object and return to the camera sensors. With this measurement, along with the speed-of-light time constant, the system can calculate the distance to the object. ToF cameras can be used for a variety of ADAS applications, such as ACC, AEB, and PAEB. They are particularly useful in low-light environments where other sensors may struggle to provide useful information. ToF cameras are becoming increasingly popular in the automotive



FOR MORE INFORMATION ON THESE PRODUCTS,
CLICK ON “PTEN E-INQUIRY”
at VehicleServicePros.com
OR CIRCLE THE NUMBER ON THE CARD.

industry as they provide an efficient and accurate way of providing CV perception. However, these technologies are still rather expensive, but as their costs come down, we're likely to see more of them in the future. You may have already seen a lidar system on a vehicle passing through your shop. See **Figure 3** to see if this looks familiar.

MONO CAMERAS

Mono cameras consist of a single camera that captures images of the environment. The camera's image sensor can detect light, and the camera's processor is able to interpret the data to produce an image. These images are then analyzed by the ADAS system to detect objects, such as other vehicles, pedestrians, and traffic signs. The technology of mono cameras has advanced over the years, which has improved their performance and capabilities for ADAS applications.

“Returning a vehicle to service in proper operating order is an essential step today, especially with all the active safety systems being deployed on vehicles.”

For example, early mono cameras used CCD image sensors that provided low-resolution images with poor low-light performance. Nowadays, most mono cameras use CMOS image sensors which provide higher-resolution images and better low-light performance. Additionally, the processing power of mono cameras has also increased, which allows them to perform more advanced image analysis in real time.

Moreover, the use of deep learning techniques within cameras is continuously advancing. This has improved their ability to detect pedestrians, bicycles, and other objects, which is important for ADAS safety features such as AEB, PAEB, and LKS.

Most recently, Honda has been able to remove the radar sensor on some of their vehicles and still achieve the same or better ADAS functionality for ACC, AEB, PAEB, LKS, and more.

STEREO CAMERAS

A stereo camera system consists of two cameras mounted side-by-side, typically forward facing, that capture images at the same time. By comparing the images captured, the stereo camera system can calculate the distance to objects in the scene providing depth perception. This is accomplished by using epipolar geometry. The known distance between the

Just add techs.

Clear, onscreen step-by-step instructions make the ADASLink[®] diagnostic scan tool your gateway to ADAS calibrations.



Scan or visit
hunter.com/adas



HUNTER
Engineering Company



Circle 43 on card or click “PTEN e-inquiry” on VehicleServicePros.com

www.VehicleServicePros.com © MAY 2023 © PROFESSIONAL TOOL & EQUIPMENT NEWS 21



▲ Figure 4 - 2022 Toyota Mirai – ADAS sensor suite including a stereo camera

“Performing ADAS sensor calibration is crucial for ensuring the safety of the driver.”

two sensors within the camera mounted on the same plane within the camera module can be used to triangulate the distance to the object being observed. Therefore, it is important to properly calibrate the camera following service events calling for those procedures. This information can be used for a variety of ADAS applications, such as ACC without the need for radar, obstacle avoid-

ance, and pedestrian detection. The stereo camera system can also be used to create a 3-D map or sometimes referred to as a point cloud of the environment within its FOV, which can be used for navigation and localization. This 3-D mapping capability is particularly useful for autonomous vehicles, as it allows the vehicle to understand its surroundings and navigate accordingly. Stereo camer-

as are becoming increasingly popular in the automotive industry as they provide an efficient and accurate way of measuring distance, which is important for the safe operation of ADAS-equipped vehicles. See Figure 4 showing a 2022 Toyota Mirai equipped with a stereo camera and an array of other sensors.

Sensor calibration is an essential step in ensuring the proper functioning of these ADAS features. Sensor calibration involves adjusting and configuring the sensors to ensure they are providing accurate and reliable data to the vehicle’s control systems.

Here are some reasons why ADAS sensor calibration is important:

- **Safety:** Accurate sensor calibration is crucial for the safety of both the driver and VRUs. Mis-calibrated sensors can lead to deficient system operation.
- **Legal compliance:** In many countries, sensor calibration is a legal requirement.
- **Performance:** Properly calibrated sensors can lead to improved ADAS performance.

In summary, performing ADAS sensor calibration is crucial for ensuring the safety of the driver and VRUs. It is important to have the calibration operations carried out by a trained service professional to ensure that it is performed properly.

CAMERA CALIBRATION

Cameras have two basic forms of calibration. The first (intrinsic) involves transforming three dimensions onto a flat plane with accurate representation. One of the challenges is the distortion that occurs as the light rays are passed through each lens element. The easiest way to visualize this, as mentioned earlier, is the viewing of straight lines on the flat image plane. This calibration operation is typically a “one and done” calibration performed at the time of camera manufacturing since it should not change. However, it is possible that there could be corrections applied dur-

ADAS Acronyms

- **ACC**
Adaptive cruise control
- **AEB**
Automated emergency braking
- **BSW**
Blind spot warning
- **CTA**
Cross-traffic alert
- **LCA**
Lane change assist
- **LDW**
Lane departure warning
- **LKA**
Lane keeping assistance
- **PAEB**
Pedestrian automated emergency braking
- **RAEB**
Rear automated emergency braking
- **RCTA**
Rear cross-traffic alert
- **TSR**
Traffic sign recognition

ing field calibration. In photography, higher-end cameras with interchangeable lenses carry calibration data that is then transferred to the camera body when mounted and operated. The calibration information is used to transform the image properly onto the flat plane of the sensor image with little to no distortion. Keep in mind that what you see being displayed may not be the exact data the imaging system is using to accomplish its job as mentioned earlier.

The second type of calibration is called extrinsic. Extrinsic basically means external and how the camera placement on the vehicle is in relation to a known datum point (usually vehicle centerline) to its field of view. If the calibration routine is classified

as static, this means that there will be a requirement for a special target(s) to be placed in specific coordinates within the camera's FOV (**Figure 5**). Many of the modern tools today provide efficiency gains with target placement operations as they relate to specific vehicle data points.

This is very important to understand because if the system does not have a

solid relationship between the camera view and the known datum point on the vehicle, then any of the warnings or corrective actions issued on an ADAS-equipped vehicle could have negative consequences. What this comes down to is that if there are changes to the vehicle ride height, steering/suspension geometry, or body-to-chassis changes,

TOPDON®

ULTRADIAG

Step Beyond The Basics With This
2-In-1 Scan Tool & Key Programmer



DIAGNOSTICS

- Bidirectional Control
- Full System Diagnostics
- 8 Reset Functions And More!

KEY PROGRAMMING

- PIN Reading
- Key Learning
- All Keys Lost And More!

TOPDON®
WWW.TOPDON.US
400 Commons Way, Suite A
Rockaway, NJ 07866-2030

TOPDON USA SUPPORT
SCHEDULE A DEMO 833-629-4832
SUPPORT@TOPDON.US



RELATED PRODUCTS



QuickADAS
OPUS IVS

Circle 45 on card or click "PTEN e-inquiry" on VehicleServicePros.com



RCCS3 Digital Innovations
TEXA

Circle 46 on card or click "PTEN e-inquiry" on VehicleServicePros.com

Phoenix ADAS Mobile
TOPDON
Circle 47 on card or click "PTEN e-inquiry" on VehicleServicePros.com



Tru-Point ADAS Calibration System
Software Update
JOHN BEAN
Circle 48 on card or click "PTEN e-inquiry" on VehicleServicePros.com



Intelligent ADAS IA900WA
Wheel Alignment and ADAS
Calibration System
Autel
Circle 49 on card or click "PTEN e-inquiry" on VehicleServicePros.com

TOOL AID® TOOLS FOR THE PROFESSIONAL

FIRST TO MARKET



Clamp Probe Set
Cat. No. 21200

Originally designed to allow a lone technician to test for voltage drop on top battery posts; its handsfree operation is a useful diagnostic tool when a third hand is needed.

- Works with standard 4mm banana plugs
- Probe swivels and adjusts in height to test where you need it
- Works great for testing recessed connections
- Clamp tips for added grip
- Available individually as the 21215 (black) and 21216 (red)

43-53 East Alpine Street, Newark, NJ 07114
973-824-7730
TOLL FREE 800-886-2080 FAX 973-621-7132
www.toolaid.com

Circle 50 on card or click "PTEN e-inquiry" on VehicleServicePros.com

then calibration operations should be considered by referencing the appropriate service information (SI). In some cases, you may not find direct statements within SI telling you that if you perform operation 'X' then you must do 'Y'. However, you may want to adopt a policy of your own. It all comes down to liability, and if you look from the courtroom perspective where the judge is looking at an owner's manual statement claiming that the AEB system may not work if the wheels are misaligned on a vehicle you aligned, and asks you why you didn't perform a recalibration on the camera when you, as the automotive service professional, knew that there is a relationship between the vehicle geometry and camera, you may be found at fault if you did not carry out the procedure. To date, I haven't been made aware of any such events I described above but they cannot be ruled out from happening.

CONCLUSION

Many service operations carried out today may require additional opera-



▲ Figure 5 - Subaru stereo camera calibration target-7810

tions to be performed that relate to ADAS. Be sure to reference up-to-date service information to ensure that complete repairs are being performed on your client's vehicles. Returning a vehicle to service in proper operating order is an essential step today, especially with all the active safety systems being deployed on vehicles.

In part two of this series, we'll dive into infrared cameras, radar, and ultrasonic sensors and some of the lessons learned during the service and repair of these systems. ❌



SCOTT BROWN is an ASE Master Certified L1 Technician and has over 37 years of professional service industry experience. He is an independent shop owner in Southern California and is engaged at various levels within the industry. He has a deep understanding of the challenges technicians experience at the service level and is continuously striving to move the industry forward through education and networking. Brown founded Diagnostic Network (diag.net) after 22 years of service at iATN, where he retired as company president in 2018.

SBrown@VehicleServicePros.com

**H&S
AUTOSHOT™**

Pull-PRO™

Portable Dent Pulling Tower

- ✓ Quickly setup and pull aluminum or steel dents with over 1,300 pounds of pulling force
- ✓ Adjustable height allows for precision pulls
- ✓ Vacuum seal allows for ultimate portability and wheels on tower for quick storage
- ✓ Optional accessories:
 - Low pull base kit (UNI-1097)
 - High pull extension kit (UNI-1098)

UNI-1096

WATCH VIDEO

HSAUTOSHOT.COM

FOLLOW US @HSAUTOSHOT

Servicing today's wheels and tires

Having the right equipment is key to properly servicing today's wheels and tires.

By Ross Colket, Contributing Editor

When it comes to providing proper service for your customer's tire and wheel needs, you'll need to invest in the right equipment. You are going to need a tire machine, a wheel balancer, wheel weights, TPMS sensors, and a triggering device.

Unfortunately, you're not going to be able to service all makes and models with just one tire machine (unless you spend a large sum of money on equipment). When deciding on the equipment to purchase, you need to look at the types of vehicles that make up your fleet. For example, a high-end piece of equipment may not be needed for luxury brand vehicles and after-market rims.

For most of our fleet, we can service with just our rim clamp, but as part of our business model, we do quite a bit of work for local body shops where our Hunter unit comes in handy.

TIRE/WHEEL EQUIPMENT

When I purchased the Atlas TC755 Tilt-Back Rim-Clamp Tire Changer (Figure 1), I also purchased the two add-on accessory arms. The tire machine has been a great purchase for us, especially with the add-ons. The arms have made mounting low-profile tires so much easier. The tire machine we had prior to the Atlas did not have provisions for adding accessory arms which was a major reason for upgrading. Prior to the new machine, I used to dread handling low-profile tires. We do about 80 percent of all our tires on that machine and



▲ **Figure 1 – Atlas TC755 Tilt-Back Rim-Clamp Tire Changer**

How do you plan to service **EV battery** packs?

BendPak's revolutionary **Mobi-EVS™** is a full-rise battery powered mobile scissor lift table that is perfectly suited for Electric Vehicle Service and EV Battery Pack replacement. With its compact design, this space-saving scissor lift can be easily transported anywhere in the workplace, making it ideal for multi-bay facilities or workplaces with confined areas.

To learn more visit www.bendpak.com/mobi-evs

Mobi-EVS™ • EV4000SL
EV Battery Pack and
Powertrain Lifting System

**4,000 lb.
CAPACITY**

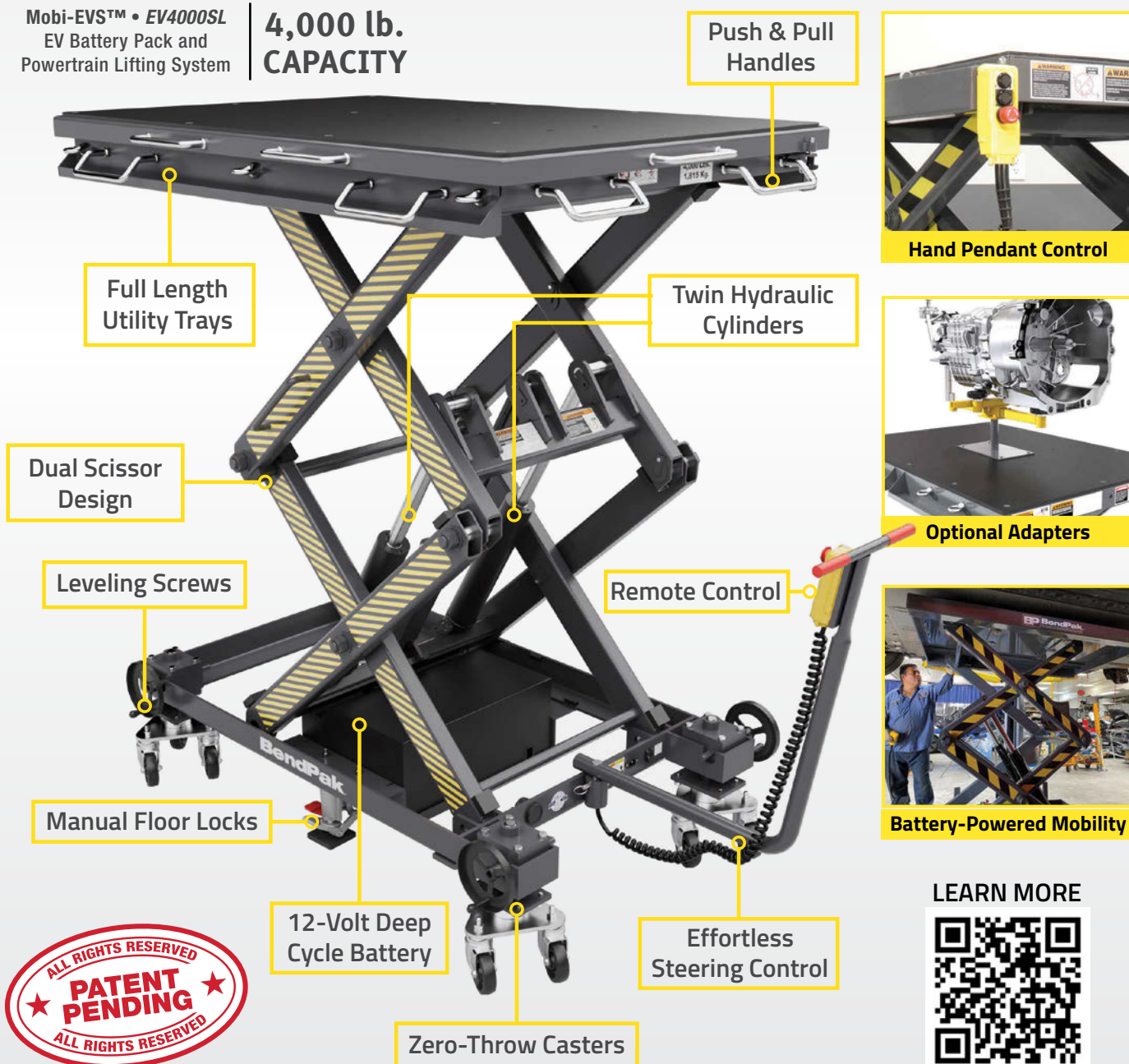

LEARN MORE



1-800-253-2363 ■ www.bendpak.com

BendPak®

© 2023 BendPak Inc. All rights reserved.

Circle 52 on card or click "PTEN e-inquiry" on VehicleServicePros.com



▲ Figure 2 – Hunter TCA28 Tire Changer

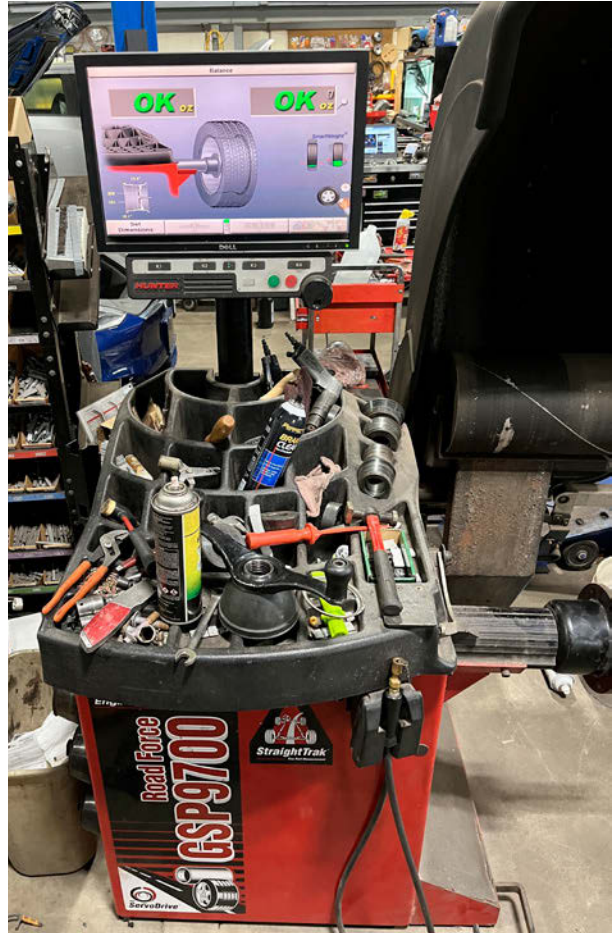

▲ Figure 3 – Hunter GSP9700 Wheel Balancer



▲ Figure 4 – NAPA wheel weight organizer

have been very pleased with the ROI. We prefer to use the rim clamp as it does tend to be quicker than the Hunter unit. It's also more forgiving to work with. My technicians take to the machine quicker as there are fewer features than our other machine.

We purchased the Hunter TCA28 Tire Changer (Figure 2) used approximately a year ago. We needed a better alternative for the higher-end rims than just our rim clamp. The unit is a bit older, but it's in good shape, which is typically the case for Hunter equipment. It can be a little challenging to get used to, but as with any Hunter machines, they have refined it in the subsequent generations. General maintenance, such as lubricating all the moving points and making sure the air dryer is empty, has been key to the longevity of this machine.

Our wheel balancer of choice is the Hunter GSP9700 (Figure 3). This was one of my first purchases when I opened

»» TOOLS USED:

- Atlas TC755 Tilt-Back Rim-Clamp Tire Changer
- Hunter TCA28 Tire Changer
- Hunter GSP9700 Wheel Balancer
- Autel MaxiSYS MS906TS
- Hunter HawkEye Elite Alignment System
- Autel IA900WA Wheel Alignment and ADAS System

the shop. It has been a great piece of equipment over the years. We have found many bent wheels with the Road Force Variation balancing. It's always comforting to know that you're able to diagnose a bent rim on the spot when servicing a vehicle. I much prefer to be able to give a customer a heads-up when they pick up the vehicle or even contact them throughout the course of the repair to keep them informed of anything out of the ordinary. It's also a great machine for luxury brands for finding potential vibration concerns. You can quickly eliminate whether it's a tire or rim issue with confidence.

ADDITIONAL PARTS AND TOOLS

It always amazes me all the ancillary items you need for complete tire service. For example, you'll need:

- Valve stems
- TPMS sensors
- TPMS service kits
- Wheel weights
- Tire lube
- Tire repair supplies

It's funny that I often think of tire service as "simple," but there's really quite a bit to it. From the evolution of plugging tires to replacing them with patch plugs and the number of different valve stem designs to the selection of wheel weights, there's a lot more to it than first meets the eye.

Because there are so many wheel weights, we chose a wheel weight assortment from NAPA that the company comes out to stock at our shop (Figure 4). On this monthly sales call, they also check our

tire repair supplies to make sure that we don't run out.

One of my frustrations for years has been TPMS systems. There wasn't one company that could do all manufacturers. These were simple systems that were forced on the industry in a relatively short period of time. Everyone, including manu-

facturers, had their own way of doing it and as a result, the industry was a mess.

One of the big things that I respect Autel for is their complete solution to TPMS. As with any aftermarket scanner, I am sure there are holes, but I have yet to run into any of them. We use the Autel MaxiSYS MS906TS (Figure 5) which has a great



asTech®

Driven by Repairify™

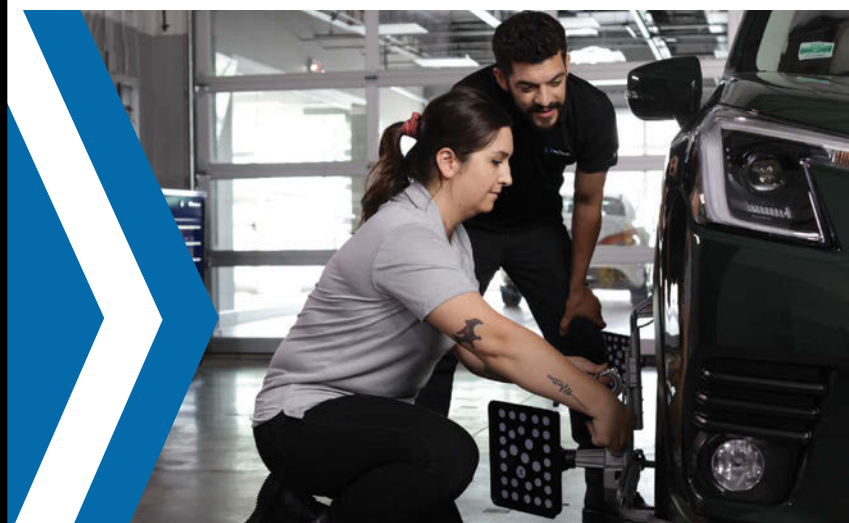

YOUR PARTNER FOR ADAS CALIBRATIONS

asTech provides the tools and training to perform calibrations at your shop.

1-888-486-1166
www.astechn.com



Circle 53 on card or click "PTEN e-inquiry" on VehicleServicePros.com

www.VehicleServicePros.com © MAY 2023 © PROFESSIONAL TOOL & EQUIPMENT NEWS 29

“It’s funny that I often think of tire service as ‘simple,’ but there’s really quite a bit to it.”

to service the tires. It’s always better to identify a problem with a sensor ahead of time.

WHEEL ALIGNMENT

Our next step is wheel alignment. I am lucky that I am in Pennsylvania, and we still have a safety inspection program. My technicians are used to inspecting vehicle suspension systems. They are trained to do that before going on the alignment rack and catching problems ahead of time. If you have a chassis component that you just can’t quite pinpoint, try doing a “dry steer test.” By having the vehicle on the ground and having

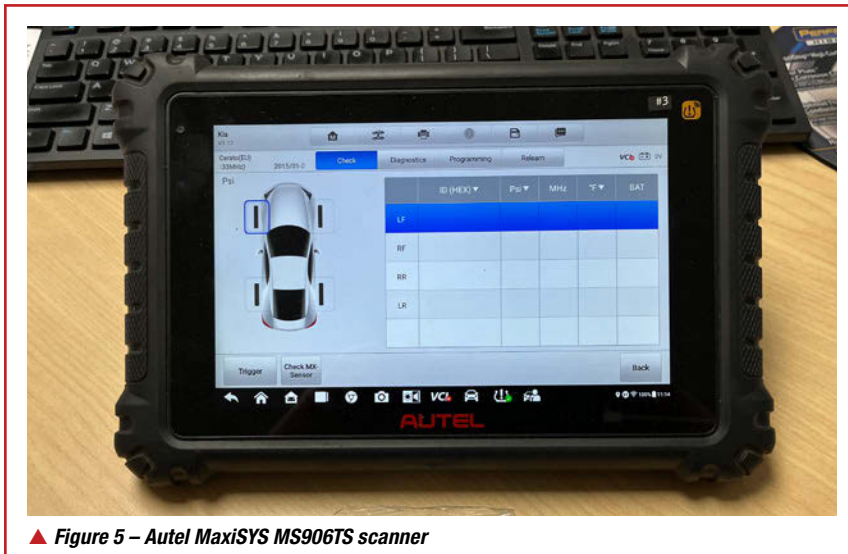

▲ Figure 5 – Autel MaxiSYS MS906TS scanner

report feature that can be printed out to show the customers ahead of time to alert them to any issues. Autel also makes one sensor for all vehicles. I can now stock just one part with my scanner, and I have

100 percent coverage. The valve stems are changeable with the click of a button. Both aluminum and rubber valve stems are available. Don’t forget to check the sensors on the vehicle before you begin

»» RELATED TOOLS



**90C Center Clamp
Tire Changer**
Coats

Circle 54 on card or click “PTEN e-inquiry” on VehicleServicePros.com



**R1090 Pro 3D
Alignment System**
Rotary Lift

Circle 55 on card or click “PTEN e-inquiry” on VehicleServicePros.com

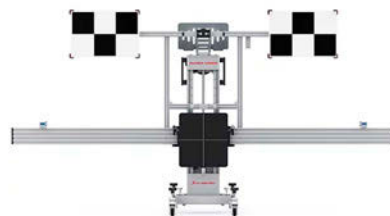

X-431 ADAS Pro Plus
Launch Tech

Circle 56 on card or click “PTEN e-inquiry” on VehicleServicePros.com



**Air Operated Tire
Spreader**

Tire Mechanics Resource

Circle 57 on card or click “PTEN e-inquiry” on VehicleServicePros.com



FOR MORE INFORMATION ON THESE PRODUCTS, CLICK ON “PTEN E-INQUIRY” at VehicleServicePros.com OR CIRCLE THE NUMBER ON THE CARD.



▲ **Figure 6 – Hunter HawkEye Elite aligner with Autel MaxiSYS MS908 ADAS**

another technician rock the steering wheel back and forth, you are more likely to find a loose component on the ground than while hanging it in the air. We use a Hunter HawkEye Elite aligner for our alignments. One of the great features of the machine is the tire clamp tar-

gets which have taken out all anxiety of potentially damaging an expensive rim.

Let's not forget the white elephant in the room, ADAS. Part of proper wheel and tire services these days should not only include a four-wheel alignment, but also any required ADAS calibrations. Where can you find out which calibrations the vehicle needs? Well, more and more we are seeing the Hunter alignment machine alert us that the vehicle is going to need a calibration before the alignment is started.

We also have a subscription to Mitchell's ProDemand and have found ALLDATA to have a great area to identify ADAS systems on vehicles and when they will need calibration.

As you can see from **Figure 6**, we have an Autel IA900WA Wheel Alignment and ADAS System next to the aligner. We do so many alignments and ADAS calibrations that we really need both

machines. By not performing the required calibrations, you are setting yourself up for potential legal problems. I have had several conversations with my insurance agent on this topic and we cannot get a good answer as to how it would be treated. Not doing a calibration is no different than not tightening caliper bolts on a brake job.

Remember if you are in the tire business, you are in the ADAS business. ❌



ROSS COLKET is the owner of Colket Automotive Technical Services in Lansdale, Pennsylvania. He is an ASE Certified Master

Technician with over 30 years of experience as both a technician and educator. As a former CTI instructor, he believes in the importance of training and giving back to the industry. Colket fully supports and believes in Motor Age's mission to "advance the automotive professional."

Ross@ColketTech.com



ARCTIC COMMANDER

RECOVERY / RECYCLE / RECHARGE MACHINES

- 🖱️ 8" COLOR TOUCH SCREEN to navigate all features and functions with ease
- 📶 WIFI CAPABILITY allows for real time, interactive communication and troubleshooting
- 💡 VISUAL INDICATOR LIGHT provides visual confirmation of machine progress
- 🕒 4" ANALOG GAUGES are class 1 rated and color coded

2 IS ALWAYS BETTER THAN 1...

COMD-RRR-KIT-2 R/R/R COMBO KIT INCLUDES:

- (1) COMMANDER2000 FULLY AUTOMATIC R134A R/R/R MACHINE
- (1) COMMANDER4000 AUTOMATIC & HYBRID R1234YF R/R/R MACHINE
- (2) FREE REFILLABLE R1234YF OIL INJECTORS (53123-YF)



WWW.MASTERCOOL.COM

PHONE: 973-252-9119 • FAX: 973-252-2455

Circle 58 on card or click "PTEN e-inquiry" on VehicleServicePros.com

www.VehicleServicePros.com © MAY 2023 © PROFESSIONAL TOOL & EQUIPMENT NEWS **31**

Matco Tools Ratcheting Hose Clamp Pliers

Reviewed by Randy Kaiser, service manager at Rost Motor Inc. in Manson, Iowa.



Q: How did the tool function as far as saving you time?

A: The Ratcheting Hose Clamp Pliers do a great job of grabbing and holding onto those pesky spring hose clamps that manufacturers seem to be very fond of using. Without this tool, those clamps can be very tough, and time-consuming to grab and compress to release them, and just as time-consuming to reinstall. This tool cuts that time down considerably.

Q: How easy was it to use?

A: The hose clamp pliers are very easy to use. You select which side of the clamping head will best fit your hose clamp (there are two different grip ranges), slide it over the clamp, and squeeze the handles together. It has a locking ratchet mechanism to

hold the clamp open, and a quick-release lever to release the tension on the clamp to reinstall it.

Q: Was there a manual included?

A: There was no manual with the pliers, just some information printed on the cardboard piece that it was attached to. It's very self-explanatory, and no manual is needed.

Q: What features did you like?

A: The pliers have two different size clamping jaws so that they can accommodate clamps from 11/16" through 3-1/8". The grip handles have a nice, rubberized coating, making them easy to grip, and very comfortable to use. There is also a quick-release handle to make it very easy to release the tension on the clamp.

Q: What types of jobs/repairs did you use this tool for?

A: I used the pliers to release spring hose clamps on heater hoses and radiator hoses during radiator replacement, water pump

replacement, and various other operations involving the cooling system.

Q: Have you used a previous version of this tool?

A: I have, but they weren't nearly as nice. The handles weren't padded at all, and the latch release didn't work nearly as well.

Q: Is there anything you had questions or concerns about in regard to the tool?

A: No, the pliers are well designed, well made, and do the job that they're designed to do. ⊗



RANDY KAISER started working at Rost Motor, Inc. shortly after graduating high school, and he is still working there 48 years later. Through the years, he has been a lube tech, line tech, paint and body tech, parts department head, service manager, and is currently in charge of the parts and service departments. Kaiser is ASE Master Certified and a Ford Master Certified Technician, as well as a Ford certified Service Manager and Service Advisor.

PRODUCT DESCRIPTION

The **Matco Tools Ratcheting Hose Clamp Pliers** are ideal for removing plastic and/or metal self-tensioning hose clamps, adjusting from 11/16" to 3-1/8". Matco's dual jaw head features one side for small and standard size hose clamps and another side for larger clamps. The ratcheting design allows the pliers to lock in place with the component, freeing up the user's hands during repairs. The pliers include a heavy duty braided cable, a clip position adjuster, and a 360-degree swivel cable assembly.

Circle 59 on card or click "PTEN e-inquiry" on VehicleServicePros.com

This product was given to the reviewer free of charge from the manufacturer.



FOR MORE INFORMATION ON THESE PRODUCTS, CLICK ON "PTEN E-INQUIRY" at VehicleServicePros.com OR CIRCLE THE NUMBER ON THE CARD.

Electronic Specialties Super Relay Buddy Pro Kit

Reviewed by Mario Rojas, lead diagnostic tech at Autobahn Performance in Oakland Park, Florida.



Q: How did the tool function as far as saving you time?

A: It saves time by bypassing any setup of independent wires. It's designed with built-in relay receptacles, which makes it convenient for efficient relay testing.

Q: How has using this tool impacted your shop's profitability?

A: It made short work of multiple relay testing, which can have a tech fumbling for leads and wires—this tool prevents that.

Q: Did it come with any accessories?

A: It came with adapters for times when you must test shielded relays.

Q: Was there a manual included? If so, did you use the manual, and was the manual easy to understand?

A: Yes, a manual is included. It's easy to read and understand. I did use it to see if they mentioned any limitations, which it did. I'll explain further below.

Q: What features did you like?

A: I like the automatic 10-cycle testing with an easy red or green pass/fail result. I also like its ability to test four- and five-pin relays, and I love that it applies a load to the circuit of 7A.

Q: Is there any way you could think to improve or add to this tool?

A: The only drawback that I see is that you cannot test relays that are not designed in the conventional format. For example, BMW/MINI utilize a green-colored relay. The diagram reflects that of a convention-

al relay, but unlike traditional relays, the BMW/MINI relays have pins 85 and 30 parallel to each other and pins 86 and 87 perpendicular to each other. The receptacle of the tool is fixed and there is no way to test these relays using the tool.

Q: On a scale of 1 to 10, how would you rate this tool overall? Why?

A: I'm going to rate this tool a nine. It's so close to perfection. Maybe its successor will be the ultimate relay testing tool and the golden standard for relay testing in the automotive industry. ❌



MARIO ROJAS is an L1 ASE Master certified Diagnostic Technician from Miami, Florida. He first began working on cars as a way to supplement his income until finally stepping into the industry full-time in 2013. He's now working at Autobahn Performance, a shop that specializes in European vehicles. Rojas also shares some of his work on his YouTube channel, **Super Mario Diagnostics**, in the hopes that his audience will appreciate what it takes to troubleshoot and repair the modern automobile, and to steer everyone into continued training.

This product was given to the reviewer free of charge from the manufacturer.

PRODUCT DESCRIPTION

The **Electronic Specialties Super Relay Buddy Pro Kit**, No. 195, includes the Super Relay Buddy tester, plus three different adapters, which increases the test coverage to ten different 12V relays. The Super Relay Buddy incorporates a full 7A load into the automated test sequence, making it capable of finding more heat/load caused failing relays. It also has a third test result (green for good, red for fail, and yellow for caution) and can test seven different 12V relays. To test, simply remove the relay from the vehicle, plug it into the relay buddy, and then press the "test" button until the test cycle is completed.

Circle 60 on card or click "PTEN e-inquiry" on VehicleServicePros.com

Bendpak Mobi-EVS EV4000SL EV Battery and Powertrain Lift Table

Reviewed by Pete Gruber, owner of Gruber Motor Company in Phoenix, Arizona.



Q: How did the equipment function as far as saving you time?

A: The Mobi-EVS EV4000SL makes a 1200 lb EV battery drop and reinstallation much quicker and safer, since we have control over alignment and maneuverability is improved. We are no longer raising and lowering the cars to remove or put battery packs up inside the cars.

Q: Have you used a previous version of this tool? If so, what are some new features compared to the old version?

A: Our custom-made battery gurneys lacked a number of key features inherent in the Mobi-EVS EV4000SL such as the hydraulics to raise, lower, or do precision lateral shifts for alignment.

ment, single-hand push button controls, and heavy duty construction.

Q: What types of jobs/repairs did you use this tool for? Please provide a few specific examples.

A: We used this on Tesla Model S, X, 3, Y, and Roadster battery packs, as well as drive train assemblies out of the Model S, X, 3, and Y.

Q: On a scale of 1 to 10, how would you rate this tool overall? Why?

A: I would rate this a 10. It is an early edition of a new emerging EV service need, and the designers nailed it the first time. 

PRODUCT DESCRIPTION

The **BendPak Mobi-EVS EV4000SL EV Battery and Powertrain Lift Table** is a push-around full-rise scissor lift table that is ideal for EV service and battery pack replacement. The 40" by 60" platform is capable of lifting up to 4,000 lbs. With a press of the button on the pendant control, the space-saving lift platform elevates to more than 6' in less than 20 seconds, the company says. Other notable features include full-length utility trays on both sides, a stowable tow bar, a heavy duty 12V DC power unit with deep cycle battery, an onboard battery charger, manual floor locks, and zero-throw casters. The lift also meets or exceeds the standards prescribed by ASME PASE 2019.

Circle 61 on card or click "PTEN e-inquiry" on VehicleServicePros.com

Q: Would you suggest any changes be made to the tool?

A: None—the design engineers did their application research and homework.

Q: How easy was it to use?

A: Once a 1200 lb battery pack is on the Mobi-EVS EV4000SL, two fingers can move it around with triple caster wheels.

Q: How was its packaging? Did it come with any accessories?

A: We received the unit in a wooden crate with accessories in separate corrugated boxes.

Q: What features did you like?

A: The four-corner leveling, slip table for precision lateral movements and align-



PETE GRUBER is an Arizona-based entrepreneur who started a hi-tech business in a residential home in North Phoenix in 1983, to design, build, and support data centers. Today, the Gruber companies include nationwide critical power equipment sales and service, data center communication products manufacturing, data center construction, and most recently, servicing electric vehicles as Gruber Motor Company (GMC).

This product was purchased by the reviewer.



FOR MORE INFORMATION ON THESE PRODUCTS,
CLICK ON "PTEN E-INQUIRY"
at VehicleServicePros.com
OR CIRCLE THE NUMBER ON THE CARD.

Streamlight Stinger Color-Rite

Reviewed by Randy Kaiser, service manager
at Rost Motor Inc. in Manson, Iowa.

**Q: How did the tool function
as far as saving you time?**

A: The flashlight is very handy to use and is a great size. It's not so small that you can misplace it, but not so large that it's too big and heavy to use. It comes with a charging dock that it can be stored in so that it's always ready to go.

Q: What features did you like?

A: This is a very well-built, very solid flashlight. It fits in the hand very nicely and has a serrated barrel for a non-slip grip. As stated in the name, this is a Color-Rite flashlight. That means that the light color that it puts out makes everything in the path of the beam appear in its true color. This not only works well for identifying paint color but is excellent for identifying



wire color and those pesky small tracer and stripe colors on wiring. It also has a pretty good battery life – 1.5 hours on high, 2.5 hours on medium, five hours on low, and three hours on strobe.

**Q: How was its packaging? Did it
come with any accessories?**

A: The packaging is actually very nice. It comes well-protected in a heavy duty box. Included in the box are a charging dock with mounting screws, a 110V charging adaptor that plugs into the charging dock, and a 12V car charging adaptor that plugs into the charging dock. Additionally, there is a rubber protective ring that can be installed onto the front of the flashlight.

Q: What features didn't you like?

A: My biggest complaint so far is how difficult it is to get the flashlight into the charging dock. If the dock is securely fastened to a bench or toolbox, and you slide the light in from the top, it is doable. If you don't have the dock fastened down or try to snap the flashlight straight into the dock, it's fairly difficult to get in. Once it's in though, it definitely stays in place.

**Q: What types of jobs/repairs
did you use this tool for?**

A: I used the flashlight for working under the hood, under the vehicle, and under the dash. It has plenty of light for any of those situations and definitely shows everything in its true color.

**Q: Have you used a previous
version of this tool?**

A: I have used many different flashlights. This is definitely the heftiest and nicest feeling one of this size that I have used. It is also probably the highest-powered one of this size that I've used, but being Color-Rite, it's not a harsh light that's hard on your eyes. ☹️



RANDY KAISER started working at Rost Motor, Inc. shortly after graduating high school, and he is still working there 48 years later. Through the years, he has been a lube tech, line tech, paint and body tech, parts department head, service manager, and is currently in charge of the parts and service departments. Kaiser is ASE Master Certified and a Ford Master Certified Technician, as well as a Ford certified Service Manager and Service Advisor.

PRODUCT DESCRIPTION

The **Streamlight Stinger Color-Rite** is a rechargeable LED flashlight that uses a high color rendering index (90 CRI) LED for enhanced visualization under low light conditions, allowing users to see the color spectrum as they would in natural light such as to match and identify colors in auto applications. The compact light offers three variable lighting modes plus a strobe: high (500 lm, 17,500 candela, 265m beam distance); medium (275 lm, 9,000 candela, 190m beam distance), and low (140 lm, 4,500 candela, 134m beam distance). Run times range from five hours on the low setting to 1.5 hours on high. The light is anodized against corrosion and is IPX4 water-resistant. **Circle 62 on card or click "PTEN e-inquiry" on VehicleServicePros.com**

This product was given to the reviewer free of charge from the manufacturer.

Kent Automotive Torrent Parts Washer

Q&A with Ilan Rodzynek, vice president of product and marketing at Lawson Products.

Q: What makes this product innovative?

A: What makes it unique is it combines three critical elements of parts washing into a single solution. One of those is heat. Even after scrubbing with a flow-through brush, some grease is going to be left behind when using cold water. It takes about 100 to 110 degrees to really get hydrocarbons or petroleum products to turn loose from many of the materials they're attached to, so the Torrent typically runs at 131 degrees, which is well above that temperature range. That heat element really delivers a cleaner product at the end of the day.

The second element is the chemistry. Most chemical reactions are more active in higher temperatures. Much of the chemistry that we're using is more environmentally friendly than some of the harsh chemicals that are used in competitors' products. The cleaning chemistry that we use produces zero VOCs and leaves behind the rust inhibitor for maximum protection of parts.

The third piece is the pressure. The pressure that the Torrent product delivers onto whatever surfaces are being cleaned blasts away tough deposits. It's 10 times more powerful than other cabinet washers. The water nozzle is powered by a recirculating pump that sprays water through the nozzle at 450 PSI. This nozzle is activated by a foot pedal and allows the user to direct the high-pressure water-based cleaning solution into the nooks and crannies of the parts being washed. The hand-activated air blower releases a jet stream of compressed air at 90 to 150 PSI to dry and remove any other loose debris.

Q: How will this product improve the lives of technicians and shop owners?

A: Technicians are paid to work on your vehicles. Spending time cleaning parts is not really what they're being paid for, so saving time is a significant element here that'll make the technician and shop owners' jobs better—makes them more profitable as well. It also keeps the workspace safer. We're using this system as an enclosed parts-washing system. It's a solvent-free approach. Shop floors can be full of grease and grime from traditional over-the-sink washers that may splash. All those problems really go away when we talk about the Torrent washer. Employees will not be exposed to harmful chemicals and with minimal use of solvent-based cleaners, this will help shop owners achieve their ISO goals as well.

Q: What has been the feedback from technicians who've purchased this tool?

A: Probably the single most consistent feedback is wow, that did the job much faster, much more effectively than whatever alternate solution they had been using in the past.

Q: Any other important features?

A: We sell these machines outright, but there are also rental options available, and for every one unit we sell, we probably rent out or lease 100 of them. The rental options that we do have for these units make them very affordable from a price point perspective. There are also service agreements that we have in place, so when you talk about having your Kent service rep out to service these machines, there are service packages associated with really what is a low-maintenance solution. 



PTEN is the only publication to feature the prestigious "Innovation Awards." Every year since 1999, the Innovation Awards highlight the newest and most innovative products introduced to the automotive aftermarket. For 2022, *PTEN* received 121 submitted product entries in 23 categories. We will be featuring the top scoring products in monthly Innovation Award Profiles. To view a full list of winners online, visit: VehicleServicePros.com/2022IAWinners.



The Innovation Awards honor companies that take their products to another level and offer unique features that make a technician's job easier. The 2023 Innovation Awards are now underway. Stay tuned for the winners to be announced in our August issue!

WATCH THE INDUSTRY'S PREMIER TECHNICAL TRAINING CONTENT!



**CHECK OUT OUR LIBRARY OF WEBINARS FOR
CUTTING-EDGE TECHNICAL TRAINING,
HOW-TO VIDEOS, TOOL DEMOS AND MORE.**

WWW.VEHICLESERVICEPROS.COM/WEBINARS

CATEGORY SPOTLIGHT

SCAN TOOLS

When it comes to diagnosing today's vehicles, the scan tool is king. But one may not be enough. Unlike buying a hand tool or socket sets, buying a scan tool is a bit more complex. With many to choose from and being a large investment, conducting research before making the big purchase is essential. Here are some latest offerings worth checking out. Also, be on the look out for next month's issue, which will include our annual Scan Tool Spec Guide supplement.

DIAGNOSES HIGH VOLTAGE SYSTEMS AND BATTERY PACKS

The **Autel MaxiSYS MSUltra EV and MS909 EV** both offer comprehensive vehicle coverage for U.S., European, and Asian electric, gas, diesel, and hybrid vehicles. Both tablets are equipped with the EVDiag Box to diagnose high voltage systems and battery packs comprehensively. The tablets provide direct access to fault locations within the high voltage system and clear and concise OE-compliant instructions to ensure optimal battery maintenance.

Circle 63 on card or click "PTEN e-inquiry" on VehicleServicePros.com



ON-SCREEN DIAGNOSTIC TOOL CHECKLIST

The latest **Opus IVS DriveSafe Software Update** includes key productivity enhancements such as the IVSMap Vehicle Blueprint and related invoicing automatically transferring to the CCC work file. The new functionality presents ADAS calibration requirements both on-screen in the diagnostic tool and uploads the results into the CCC work file for the vehicle. An on-screen diagnostic tool checklist also provides guidance and documentation that critical calibrations are completed before the post-scan runs.

Circle 64 on card or click "PTEN e-inquiry" on VehicleServicePros.com

Every Toolbox Needs...

WALTON

Tap Extractors & Tap Extensions

Performance professionals have depended on high-quality Walton tools since 1908.

TAP EXTRACTORS

- Remove broken taps simply and safely – without drilling, lasers, damaged threads, scrapped parts or repair inserts.
- Available in every tap size, inch and metric.

TAP EXTENSIONS

- Extend the reach of regular-length taps and allow for tapping in deep holes and awkward locations.
- Square and round sockets conform to leading tap sizes.
- Suitable for both machine- and hand-tapping.

Available as sets or individual pieces.

WALTON
COMPANY



Tapping into good ideas for 115 years.



(860) 523-5231 • sales@waltontools.com

www.WaltonTools.com

ABLE TO SELECT LEVEL OF COVERAGE

The Matco Tools Maximus Flex Pro Diagnostic Scan Tool

is an Android-based tablet with 10.1" high resolution touchscreen that is designed to be flexible to meet the needs and budget of any automotive technician. Users can choose the level of coverage that works for them, from fully-loaded coverage, monthly subscriptions, or as an enhanced code reader with maintenance resets. Additionally, the scan tool offers remote diagnostics, vehicle maintenance history records, and a built-in VCI that supports CAN, CANFD, DoIP and more automotive communication protocols with optional DoIP cable. It also fully supports the security gateway module with access to select 2018 and newer FCA US vehicles with Auto Auth subscription (purchased separately) and includes a rugged case.

Circle 66 on card or click "PTEN e-inquiry" on VehicleServicePros.com



FOR MORE INFORMATION ON THESE PRODUCTS, CLICK ON "PTEN E-INQUIRY" at VehicleServicePros.com OR CIRCLE THE NUMBER ON THE CARD.

Austin Matney,
2022 Best Young
Tech Award winner

INTRODUCING
THE

BEST

★ YOUNG TECH ★

AWARD

20 X 23

Honoring technicians aged 35 and younger who are moving the service repair industry forward, who excel in their current roles and are passionate about their work.

DEADLINE TO ENTER: **JUNE 2, 2023**

Prizes

- ✘ Trip to 2023 AAPEX/SEMA Show in Las Vegas
- ✘ Trip for two to the STX Supplier and Training Expo in Nashville in April 2024
- ✘ Tools & Equipment from contest sponsors
- ✘ Award plaque and uniform patch

Qualifications

- ✘ Techs aged 35 or younger
(Must be born after January 1, 1988)
- ✘ At least 2 years experience in the industry
- ✘ Shown career development, innovation in their role, technical or educational achievement, community service and importance to the shop
- ✘ Techs can be nominated or nominate themselves



VISIT vehicleservicepros.com/2023bestyoungtech
FOR MORE INFO OR TO SUBMIT YOUR NOMINATION TODAY!

BROUGHT TO YOU BY:



VEHICLE
SERVICE
PROS

MOTOR AGE

PTEN

RATCHET
& WRENCH

MTE

NOLN

Auto Service
Professional



CATEGORY SPOTLIGHT

Scan Tools



OFFERS FULL-SYSTEM VEHICLE DIAGNOSTICS

The **Launch Tech X-431 Torque 5** is a tri-function device that serves as the VCI for OBD diagnostics in addition to a digital multimeter and a two-channel oscilloscope. The bidirectional Torque 5 also includes extensive coverage of European, Asian, and Domestic vehicles, with pre-installed software modules for ADAS, battery testing, immobilizer diagnostics, CodeAssist by Identifix, and more. The Android 10-based scan tool features a 10.1" color display, 4GB ram and 128GB ROM large storage, and is equipped with a high-endurance battery. It also supports CANFD/OIP diagnostic protocol and full-system fault diagnostics.

Circle 67 on card or click "PTEN e-inquiry" on VehicleServicePros.com



USES ANY SMARTPHONE

The **TOPDON TopScan** is a pocket-sized tool designed to turn any smartphone into a professional-grade scanner. TopScan is capable of reading and clearing fault codes for over 60 different vehicle makes across American, Asian, and European vehicles, as well as offers advanced diagnostics and bidirectional control through the user's phone. With TopScan, users can access eight maintenance services, AutoVIN technology, vehicle performance testing, and a repair data library. Additionally, it offers Bluetooth connectivity and multilingual support, includes feedback functions, and can test emissions easily with a one-click I/M ready button that generates a testing report.

Circle 68 on card or click "PTEN e-inquiry" on VehicleServicePros.com



ADDS 'MANAGE PHOTOS' FEATURE

The **Bosch ADS and ADS X 5.1, 5.2, and 5.3 Software Updates** further improve user experience by introducing a 'manage photo' feature, allowing technicians to launch the camera or upload existing photos to scan reports, special tests, and calibration reports. Additionally, the software updates add new special tests, systems applications, more 2022 coverage, and new 2023 vehicle coverage. The ADS software updates include coverage for domestic and foreign 2022 and 2023 vehicle coverage. Bosch ADS users with a current subscription can install the updates after automatically receiving the download.

Circle 69 on card or click "PTEN e-inquiry" on VehicleServicePros.com

ULINE

WAREHOUSE ESSENTIALS



HUGE SELECTION OF PALLET RACKING IN STOCK

COMPLETE CATALOG
1-800-295-5510 uline.com

Circle 70 on card or click "PTEN e-inquiry" on VehicleServicePros.com

40 PTEN © MAY 2023 © www.VehicleServicePros.com

New Relay Buddy!

194 Super Relay Buddy®



- Full 7 Amp load during the test
- Relay voltage drop monitored
- **Ten second test!**
- Test results displayed as red, green or yellow for caution

- Tests 7 different 12 volt relays
- More effective test finds intermittently bad relays

195 Super Relay Buddy® Pro Kit

- Kit includes adapters for expanded test coverage - 10 different 12V relays



Call 800-227-1603 for more info. - www.esitest.com



Circle 71 on card or click "PTEN e-inquiry" on VehicleServicePros.com



FOR MORE INFORMATION ON THESE PRODUCTS,
CLICK ON "PTEN E-INQUIRY"
at VehicleServicePros.com
OR CIRCLE THE NUMBER ON THE CARD.

CATEGORY SPOTLIGHT



Scan Tools



FEATURES A FULLY DETACHED FOUR-CHANNEL SCOPE

The **Snap-on ZEUS+** is an advanced information-driven scan and scope device, offering onboard storage and processing and communications capabilities. Fast-Track Intelligent Diagnostics simplifies the diagnostic process and guides technicians through the repair, avoiding unnecessary steps along the way. It includes SureTrack for verified parts replacement records and real fixes, smart data for relevant vehicle and code specific PIDs, and prefiltered functional tests and guided component tests to verify repairs. ZEUS+ also delivers software coverage, processing power and speed, and access to the information needed for technicians to work quickly and efficiently.

Circle 72 on card or click "PTEN e-inquiry" on VehicleServicePros.com



INCREASED COVERAGE FOR OFF-HIGHWAY CONSTRUCTION VEHICLES

Noregon's latest JPRO Professional 2023 v1 Update includes a significant increase in coverage for off-highway construction vehicles and equipment. Users will also receive coverage for many popular models of equipment from major OEs such as Caterpillar, John Deere, and Komatsu. Additionally, the latest update provides increased support for the growing alternative fuel market as well as enhanced support and bidirectional coverage for many vehicle systems, including ADAS, engine/aftertreatment, brakes, and more. Customers with an active JPRO subscription can update via a prompt in the software or from the company's website.

Circle 73 on card or click "PTEN e-inquiry" on VehicleServicePros.com



Watch this product in action here:
VehicleServicePros.com/53028813



SUPPORTS 10 OBD-II MODES

The **Mac Tools Elite Code Reader, No. ET1600**, has a 4" touchscreen, is Android based, and supports 10 OBD-II modes and CAN protocols. It has six reset service functions, including BMS, oil, EPB, ABS bleeding, SAS, and brake. The ET1600 provides OE-level U.S. vehicle coverage as well as Asian and European coverage from 1996 and newer. It's capable of reading and erasing DTCs for ABS, SRS, engine, and transmission systems as well as automatically generates diagnostic health reports for sharing and analyzing. It also auto-detects VIN, offers multilingual menu and code definitions, and can graph, record, and playback diagnostic data with live streams.

Circle 74 on card or click "PTEN e-inquiry" on VehicleServicePros.com



WORKS AS A FULL DPF SERVICE TOOL

The **CanDo HD Code Pro** is a mid-line code scanner that will diagnose light to heavy duty commercial vehicles. The scanner reads and clear codes as well as performs DPF resets and regens. In addition, the scanner allows users to perform SCR, ash and soot level resets, along with service maintenance resets. The full DPF service tool also comes with manufacturer-specific engine, brakes, and transmission coverage.

Circle 75 on card or click "PTEN e-inquiry" on VehicleServicePros.com



MARKETPLACE

Contact Mackenzie Verschoor at
MVerschoor@EndeavorB2B.com for
advertising information.

JB TOOLS

**BEST TOOLS.
UNBEATABLE PRICES.**

SHOP NOW



www.jbtools.com

TURN YOUR TOOL IDEA INTO MONEY

LISLE CORPORATION CURRENTLY PAYS ROYALTIES TO OVER 120 INDIVIDUALS.

Lisle has been in business for over 110 years and for over 40 years have been working with individuals on an award or royalty basis. If you have an original tool idea which others may need, we have a procedure to evaluate your idea.



Respond now to request an idea disclosure packet.

P.O. Box 89 • Clarinda, IA 51632-0089
712-542-5101 • Fax 712-542-6591
www.lislecorp.com/about/program

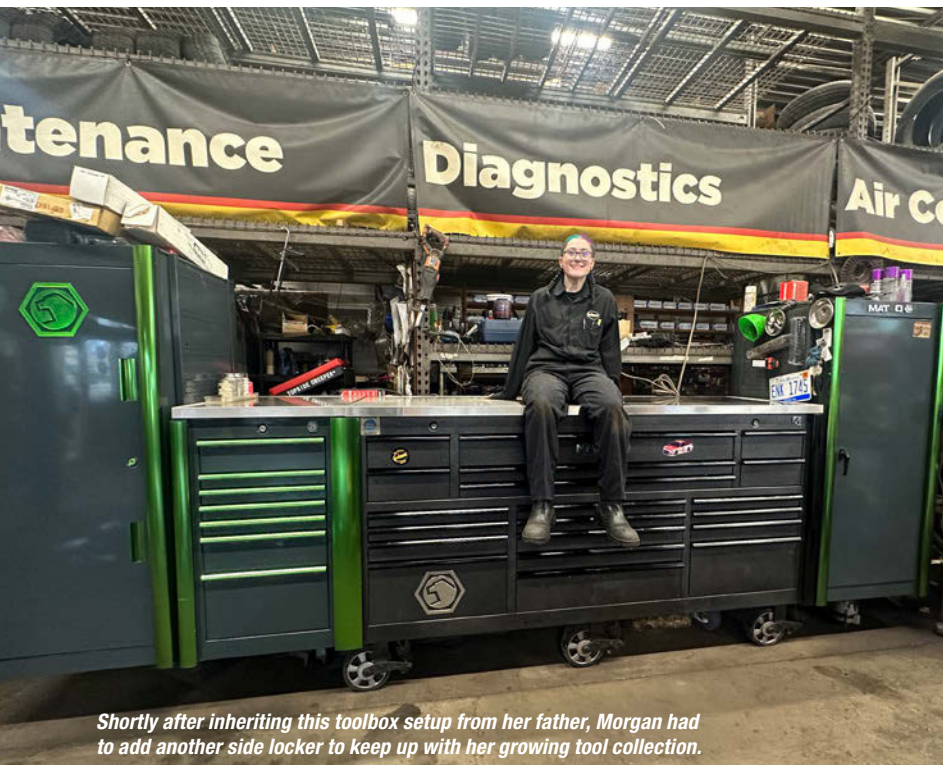

Shortly after inheriting this toolbox setup from her father, Morgan had to add another side locker to keep up with her growing tool collection.

Keeping it in the family

This technician obtained her current toolbox setup, not by purchasing it, but by inheriting it from her father.

By *Emily Markham*, Editor

A year and a half ago, automotive technician Tiffany Morgan received what is arguably the best Christmas gift a technician could receive—a new toolbox filled with tools. Working at the same Midas shop in Troy, Michigan, Morgan’s father decided to retire and pass down his toolbox and everything in it to his daughter.

The setup consists of all Matco Tools products including a triple-bay toolbox, a single-bay toolbox, and two lockers, one on each side. Morgan had to add the second locker only a few months ago because she had already run out of space in the now 14’ long setup. She notes that this is one of Matco’s deepest toolboxes at

»»» OWNER

Tiffany Morgan
 Shop: Midas
 Location: Troy, Michigan

around 30-31” deep. Morgan’s favorite part of the setup is her new side locker. She made sure the locker included a power drawer, so then she wouldn’t have to keep all her power tools on top of her toolbox anymore.

To keep her box ready for work each day, Morgan likes to keep her tools organized in a logical fashion—similar-sized sockets grouped together in a drawer, SAE wrenches on one side and metric on the other, similar tools like prybars all clustered together, and so on.

Organization isn’t a problem for Morgan, but she does note, “I just need more drawers.” All the drawers in her setup are currently filled with tools and equipment, except for one drawer in her smaller side locker that’s filled with nuts and bolts.

Funnily enough, Morgan’s favorite tool isn’t stored in her toolbox setup. Her TraXion Topside Creeper lives behind the setup and comes in handy whenever she needs a bit of a boost. At a height of 5’2”, Morgan notes that “I kind of need [it] to get level to get up and do everything.”

TOGETHER FROM THE START

Aside from her father’s toolbox, Morgan also inherited his passion for working on cars.

“I started working on cars with my dad when I was two years old, and it just kind of stuck.”

Morgan’s now been working in this industry for almost ten years, and after that much time—and growing out of her fair share of toolboxes—she’s picked up a thing or two on what to consider when purchasing a toolbox.

“You just [have to] see what all tools you have and how [they’re] going to fit,” she advises. “If you have to go bigger or smaller, it all depends on what you do every day.”

FUTURE MODIFICATIONS

Looking ahead, Morgan has a few modifications she’d like to make to the setup, starting with green handles/trim. Currently, only her side lockers and the single-bay toolbox are sporting the lime green accents, but now that their shop has a Matco Tools distributor visiting them again, she’d like to update the triple-bay toolbox to make everything match.

Additionally, she’s been thinking about adding a hutch and a mini fridge to her setup. However, she’s still debating the hutch, as installing that would take away her workspace. ☒

Want to see more photos of Morgan’s box? Visit: [VehicleServicePros.com/53058332](https://www.vehicleservicepros.com/53058332)



Want to show off YOUR Big-Time Box? For more information, email Editor@VehicleServicePros.com.

RAISING THE STANDARDS OF EXCELLENCE

AP SERIES™

*NEW 360-Degree Automatic Swing Arm Restraint System
Provides the Ultimate In Safety and Vehicle Fall Protection*

**NEW
ARRIVAL**
SHOP NOW



Model: **10AP**
10K lb. Capacity
Two-Post Lift

LEARN MORE 



Certified to meet the
standards of ANSI/ALI
ALCTV: 2017



Bi-Metric Swing Arms

Our 10AP Series offers the convenience of wide or narrow installation wrapped up into one configurable package. This durable, safe, and reliable car lift features an expandable top beam and BI-METRIC™ arms to suit virtually every vehicle lifting requirement – symmetric or asymmetric. The 2-in-1 design gives operators the option of loading vehicles either symmetrically (centerline of vehicle at column) or asymmetrically (centerline of vehicle behind column). The simple, yet highly sophisticated is sure to keep operating costs low and productivity high.

Check out the full line of 10AP lift series at bendpak.com/10AP or call us at **1-800-253-2363**.

1-800-253-2363 • BENDPAK.COM

©2023 BendPak Inc. All rights reserved.

BendPak®

Circle 76 on card or click "PTEN e-inquiry" on VehicleServicePros.com

LAUNCH TECH USA

CREATE • CHANGE

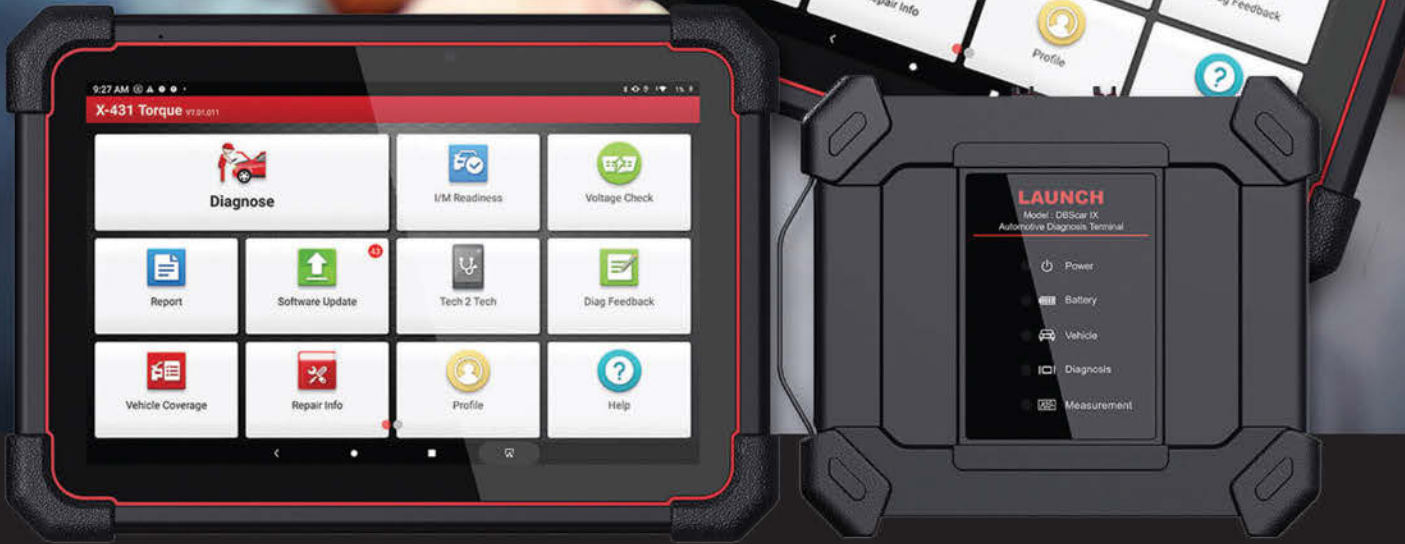

X-431 TORQUE 5

ADVANCED VEHICLE DIAGNOSTIC SYSTEM

X-431 Torque 5, the Android based advanced intelligent diagnostic system, adopts the new DBSCARIX Bluetooth diagnostic connector which integrated 2-channel oscilloscope/ multi-meter and supports CANFD/DoIP diagnostic protocols. It also supports full system fault diagnosis, with functions such as Read DTCs, Clear DTCs and more.

FEATURES:

- OE-level U.S. vehicle coverage as well as Asian, and European coverage from 1996 and newer.
- Support communication protocols DoIP (need adapter) /CAN/CANFD.
- Guided function for VW & Audi.
- OE-Level bi-directional functionality.
- TECH 2 TECH remote diagnostics and technician collaboration.
- Auto detect VIN to access the vehicle information within seconds.
- Extra software or other products can be purchased throughout Launch Mall. (NEW)
- OE vehicle approved Security Gateway access by FCA certified. (NEW)
- Code Assist by Identifix, access most common fixes and repair solutions with corresponding DTC's. **IDENTIFIX**
- Support X-431 Fix Repair information, driven by Motor. **MOTOR DRIVEN**
- Monitor vehicle's voltage by real-time displaying the data during diagnosing. (NEW)
- Vehicle health report feature gives comprehensive status on all onboard systems of vehicle.
- Support optional extension modules, ADAS calibration, ADAS HD, Immobilizer, Battery Tester, Videoscope, HD Add-on Module, Scopebox, and Sensorbox.
- Integrated 2-channel oscilloscope and multi-meter functions.

Circle 77 on card or click "PTEN e-inquiry" on VehicleServicePros.com

LAUNCH

 www.launchtechusa.com

 1-877-528-6249

   @LaunchTechUSA