

SACRIFICE NOTHING

✓ Cut Protection up to A9 ✓ 50% Lighter ✓ Unmatched Dexterity



You can have it all.

Experience the lightest cut resistance ever with the AeroDex® Series from Magid.



GET A PAIR! FREE magidglove.com/aerodex-pten
800-203-9540

#GPD482

MAGID

Safety at work®

PTEN

PROFESSIONAL TOOL & EQUIPMENT NEWS

\$15.00 • October 2022
Volume 33, Number 9

ENDEAVOR
BUSINESS MEDIA

NITROUS KEY MAKING SYSTEM

BY XTOOLUSA



**DIAGNOSTIC
TECH**
ELECTRONIC
CONTROLS
PAGE 21

**TOOL
BRIEFING**
CAN BUS
STRATEGIES
PAGE 28

PTEN
**PEOPLE'S
CHOICE**
2022
AWARD WINNERS

PAGE 40

DETAILS ON THE COVER PRODUCTS
AND OTHER NEW TOOLS **PAGE 10**



▲ Has an accuracy
of ± 4 percent



▲ Advanced nitrile
coated palm for
better grip



▲ Offers rapid EV
battery pack testing



30TH ANNIVERSARY PROMOTIONAL

POWER PROBE IS CELEBRATING
30 YEARS OF HELPING TECHNICIANS

SALE

Power Probe Professional Electrical Test Kit

SKU: PPROKIT01

This Power Probe 3 Master Combo Kit pairs the Power Probe III with the PPDMM CATIV Digital Multimeter and a variety of accessory lead and adapters. Combined they can tackle even the toughest electrical diagnosis.



FREE

With purchase
of PPROKIT01

Power Probe Pro-Solder
50 worth **\$137.95**

- Cordless Solder Kit
- Rechargeable Battery
- Multiple Tips
- 50 Watt



Power Probe 4 Master Combo Kit

SKU: PPKIT04

This Power Probe 4 Master Combo Kit is the most powerful kit in the Power Probe line-up. Combines the capabilities of the mighty Power Probe IV and its built-in full multimeter test modes, packaged together with the ECT3000 Circuit Tracer for locating open and short circuits.



FREE

With purchase
of PPKIT04

**Power Probe Breakout
Box** worth **\$280.95**

- Check Communication Network Health
- Built-In Volt Meter
- Test OBD Port for Shorts
- Provides Live Display Of Communication Signals



Power Probe 3 Gold Series Lead Set

SKU: PP3LS01

The PP3LS01 kit combines the Power Probe III with a variety of extension leads and adapters to make connecting to any circuit easier, and it all stores in a custom blow mold case.



FREE

With purchase
of PP3LS01

**Power Probe Butane
Torch** worth **\$84.95**

- Used For Soldering, Brazing, Stubborn Fasteners
- Heavy Duty Electronic Igniter
- 45 Gram Tank Capacity
- 60 Minute Run Time



Circle 1 on card or click "PTEN e-inquiry" on VehicleServicePros.com

Promotion only valid at participating dealers | While stocks last | Terms and conditions apply

THINKCAR

WIN WITH TECHNOLOGY!

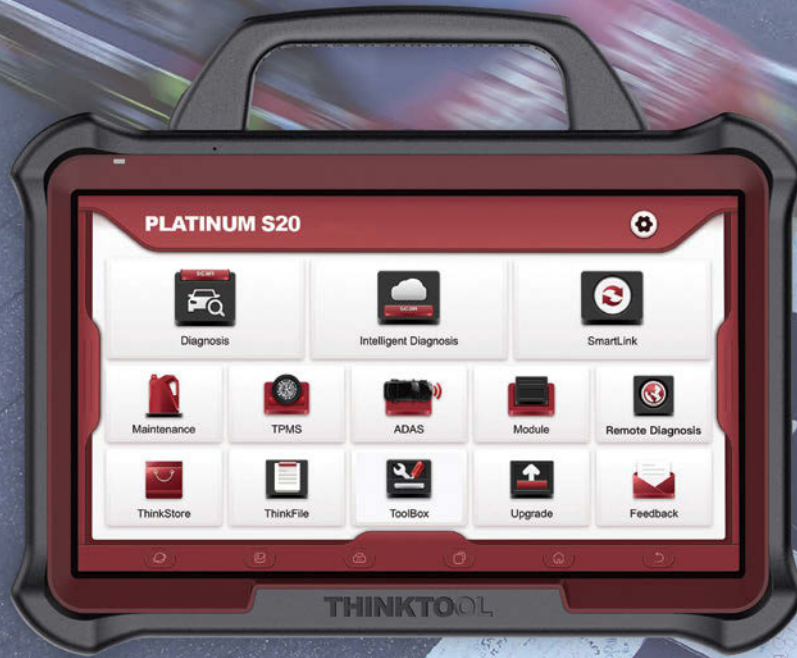

GET THE TECH YOU NEED TO WIN!

We invest over \$200M annually in R&D to ensure the Platinum series provides unbeatable performance!

MEET RICHARD PETTY

AAPEX, Nov 1, 2022
THINKCAR Booth A433



43

2022 All Petty marks used under license from Petty IP,LLC.

SEE YOU LOCAL TOOL DEALER OR DISTRIBUTOR TO EXPERIENCE THE PERFORMANCE OF THE PLATINUM SERIES!



PLATINUM S6



PLATINUM HD



PLATINUM S20



PLATINUM S10 PRO

Circle 2 on card or click "PTEN e-inquiry" on VehicleServicePros.com

THINKCAR Tech, Inc.

US Tech Support Ph: 833-692-2766 | Business Hours Mon - Fri 8am - 5pm PST

CONTENTS

ON OUR COVER



34



60



Nitrous Key Making System by XTOOLUSA

Details on page 10.

EXCLUSIVES

40 PEOPLE'S CHOICE WINNERS

See which products caught readers' eyes for this year's People's Choice Awards.

54 BEST YOUNG TECH

We reveal the winner of our second annual Best Young Tech Award.

58 SOCIAL INFLUENCER

PTEN welcomes The Flat Rate Master to the team.

59 INNOVATION AWARDS PROFILE

Learn more about one of this year's most innovative new products.

PRODUCTS

10 NEW PRODUCTS

Check out the latest offerings from Cat Footwear, Platinum Tech, Weego, and more.

36 TOOL REVIEWS

Our review panel tests out four different tools and gives their feedback.

60 CATEGORY SPOTLIGHT

Tool Storage

COLUMNS

8 EDITOR'S NOTE

Do your tools go "one louder?"

21 DIAGNOSTIC TECH

Scott Brown discusses how electronic controls are over taking many of the mechanical systems we once saw on vehicles in years past.

28 TOOL BRIEFING

Ross Colket takes a look at network diagnostic tools and strategies.

66 BIG-TIME BOXES

Marc Weinberger, Marc's Towing and Auto Repair in Kingston, N.Y.



66

PTEN

PROFESSIONAL TOOL & EQUIPMENT NEWS

Published by Endeavor Business Media, LLC

ENDEAVOR
BUSINESS MEDIA

30 Burton Hills Blvd, Ste 185
Nashville, TN 37215
800-547-7377

Printed in the U.S. Volume 33, Number 9; October 2022

EXECUTIVE VICE PRESIDENT – TRANSPORTATION

Reggie Lawrence RLawrence@EndeavorB2B.com

VP/GROUP PUBLISHER, ENDEAVOR VEHICLE REPAIR GROUP

Kylie Hirko
630-253-4034 Kylie@VehicleServicePros.com

EDITOR Brendan Baker
BBaker@EndeavorB2B.com

ASSOCIATE EDITOR Emily Markham
920-234-6359 EMarkham@EndeavorB2B.com

ASSOCIATE EDITOR Kayla Oschmann
920-563-1764 KOschmann@EndeavorB2B.com

TECHNICAL EDITOR Brandon Steckler

ASSOCIATE SALES DIRECTOR Mattie Gorman-Greuel
920-563-1636 MGorman@EndeavorB2B.com

DIRECTOR OF BUSINESS DEVELOPMENT Cortni Jones
920-568-8391 CJones@EndeavorB2B.com

MULTIMEDIA ACCOUNT EXECUTIVE Diane Braden
920-568-8364 DBraden@EndeavorB2B.com

MULTIMEDIA ACCOUNT EXECUTIVE Lisa Mend
949-259-5654 LMend@EndeavorB2B.com

MULTIMEDIA ACCOUNT EXECUTIVE Michael Parra
925-307-8779 MParra@EndeavorB2B.com

MULTIMEDIA ACCOUNT EXECUTIVE Paul Ropski
815-255-4118 PRopski@EndeavorB2B.com

INSIDE SALES James Hwang
801-823-1704 JHwang@EndeavorB2B.com

PRODUCTION MANAGER Jane Pothlanski
224-324-8507 JPothlanski@EndeavorB2B.com

AD SERVICES MANAGER Carmen Seeber
920-568-8373 CSeeber@EndeavorB2B.com

ART DIRECTOR Tim Schafer

LIST RENTAL REP Michael Costantino
402-836-6266 Michael.Costantino@infogroup.com

LIST RENTAL REP Kevin Collopy
402-836-6265 Kevin.Collopy@infogroup.com

AUDIENCE DEVELOPMENT MANAGER Debbie Dumke

ENDEAVOR BUSINESS MEDIA, LLC

CEO – Chris Ferrell

President – June Griffin

CFO – Mark Zadell

COO – Patrick Rains

Chief Administrative and Legal Officer – Tracy Kane

EVP/Group Publisher - Transportation – Reggie Lawrence

EVP Marketing Solutions & Data – Jacquie Niemiec

Subscription Customer Service

877-382-9187; 847-559-759

Circ.ProfDistmag@omeda.com

PO Box 3257 • Northbrook IL 60065-3257



Article reprints reprints@endeavorb2b.com

Professional Tool & Equipment News (USPS 012-426, ISSN 1081-4485 print; ISSN 2150-2072) is published ten times a year in February, March, April, May, June, July, August, September, October, and December by Endeavor Business Media, LLC, 1233 Janesville Avenue, Fort Atkinson, WI 53538. Periodicals postage paid at Fort Atkinson, WI 53538 and additional mailing offices. POSTMASTER: Send address changes to Professional Tool & Equipment News, PO Box 3257, Northbrook, IL 60065-3257; Canada Post PM40612608. Return undeliverable Canadian addresses to: Professional Tool & Equipment News, PO Box 25542, London, ON N6C 6B2.

Subscriptions: Individual subscriptions are available without charge in the U.S. to qualified subscribers. Publisher reserves the right to reject non-qualified subscriptions. Subscription prices: U.S. \$50 per year, \$93 two year; Canada/Mexico \$72 per year, \$131 two year; All other countries \$105 per year, \$195 two year. All subscriptions payable in U.S. funds, drawn on U.S. bank. Canadian GST#R42773848. Back issue \$10 prepaid, if available. Printed in the USA. Copyright 2022 Endeavor Business Media, LLC.

All rights reserved. No part of this publication may be reproduced or transmitted in any form or by any means, electronic or mechanical, including photocopy, recordings or any information storage or retrieval system, without permission from the publisher.

Endeavor Business Media, LLC does not assume and hereby disclaims any liability to any person or company for any loss or damage caused by errors or omissions in the material herein, regardless of whether such errors result from negligence, accident or any other cause whatsoever. The views and opinions in the articles herein are not to be taken as official expressions of the publishers, unless so stated. The publishers do not warrant, either expressly or by implication, the factual accuracy of the articles herein, nor do they warrant any views or opinions offered by the authors of said articles.



THE POWER OF EVOLUTION

SECURE HIGH VOLTAGE SYSTEM TESTING



MAXISYS MS909

MAXISYS ULTRA

DETAILED BATTERY PACK DIAGNOSTICS
STATE OF CHARGE & STATE OF HEALTH ANALYSIS

SPECIALIZED BATTERY ANALYSIS VIA BMS
DETAILED CABLE CONNECTION DIAGRAMS

POWERFUL HARDWARE

- 12.9" Touchscreen (Ultra)
- Octa-core Processor
- Android 7.0 System
- 4G+256G Storage

INTELLIGENT SOFTWARE

- EV High-Voltage System Diagnostics
- Covers All Functions Of Ultra
- Topology Module Mapping
- Repair Guided Procedures
- Related TSBs / DTC Analysis



EV DIAGNOSTICS UPGRADE KIT

KIT INCLUDES

EVDiag Box & Adapters for Specific Electric Vehicles to Perform Battery Pack Analysis.

COMPATIBLE TABLETS

- MaxiSYS Ultra
- MaxiSYS Ultra ADAS
- MaxiSYS MS919
- MaxiSYS MS909

(Connects to MaxiFlash VCI or VCMI)

Circle 3 on card or click "PTEN e-inquiry" on VehicleServicePros.com

SUPPORT: 1.855.288.3587
EMAIL: USSUPPORT@AUTEL.COM | WEB: AUTEL.COM
VIEW MARKETING MATERIAL: ISSUU.COM/AUTEL2
FOLLOW US @AUTELTOOLS



AUTEL®

NOW ONLINE AT **VEHICLESERVICEPROS**.com

VIDEO



PTEN Tool Review: Eric Moore, fleet manager at Griffin Pavement Striping in Columbus, Ohio, reviews the Milwaukee Tool M18 Inflator, an 18V cordless tire inflator designed to meet the needs for transportation maintenance professionals by providing ideal performance, versatility, and the durability to survive demanding jobsites.

[VehicleServicePros.com/21278814](https://www.vehicleservicepros.com/21278814)

AROUND THE SHOP



When considering lighting for your automotive shop, you want to purchase lights, both corded and battery-operated. Here are five features to consider when purchasing work lighting.

[VehicleServicePros.com/21278165](https://www.vehicleservicepros.com/21278165)

CASE STUDY



A customer brought in their 2018 BMW because the A/C was not working. Another shop had already replaced the expansion valve and recharged the system, but that did not fix the problem.

[VehicleServicePros.com/21277302](https://www.vehicleservicepros.com/21277302)

PODCASTS



Enjoy the fall scenery while catching up with this month's playlist featuring podcasts discussing the outlook of electric vehicles, everything you need to know about insuring your auto repair shop, sales tips to outsell your competition, and more.

[VehicleServicePros.com/21280100](https://www.vehicleservicepros.com/21280100)

MARKETING STRATEGIES



It's natural to hit a marketing plateau. Here are twelve top auto repair marketing strategies to reach all your potential audiences – from existing to new customers.

[VehicleServicePros.com/21280184](https://www.vehicleservicepros.com/21280184)

FEATURED PRODUCTS



Howmet Fastening Systems

Marson Klik-Turn SP-2
Swivel Head Rivet Tool

[VehicleServicePros.com/
21280611](https://www.vehicleservicepros.com/21280611)

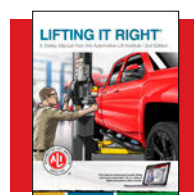

Automotive Lift Institute's

Lifting It Right Second Edition

[VehicleServicePros.com/
21279982](https://www.vehicleservicepros.com/21279982)



Lisle Corporation

Molding Clip Remover,
No. 83220

[VehicleServicePros.com/
21279758](https://www.vehicleservicepros.com/21279758)



Mac Tools

17-pc Ratcheting Stubby
MB Set, No. SBDR17SS

[VehicleServicePros.com/
21263496](https://www.vehicleservicepros.com/21263496)

A powerhouse lineup of repair solutions from the global leader in diagnostics



Professional Diagnostics

The next generation of scan tools with the most advanced OE level vehicle coverage supporting scanning, live data access and complete bi-directional functions.

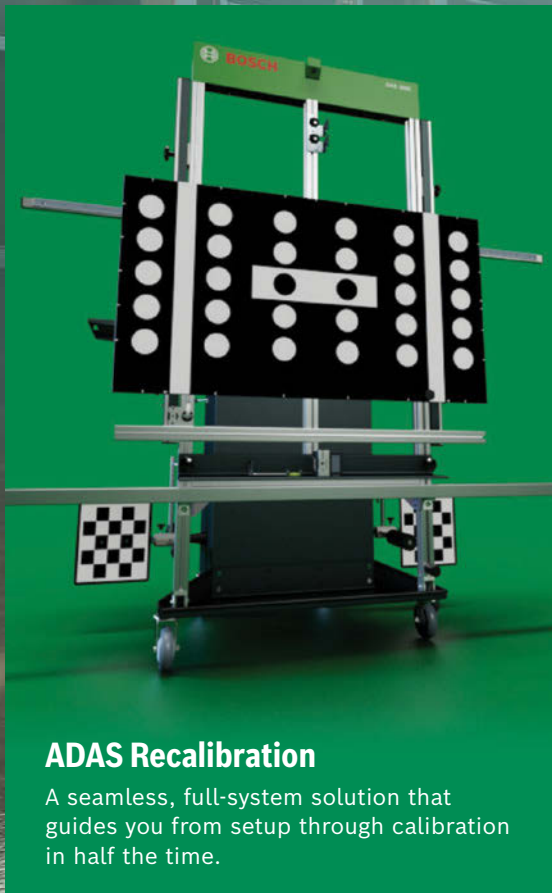

ADAS Recalibration

A seamless, full-system solution that guides you from setup through calibration in half the time.



Heavy Duty Diagnostics

Heavy duty solutions to help you get the repair done right and the vehicle back in operation.



Test, Tune and Analyze

Test, analyze and diagnose your vehicle electrical and mechanical systems.

Circle 4 on card or click "PTEN e-inquiry" on VehicleServicePros.com

Solutions for every job.

boschdiagnostics.com

Visit us at AAPEX
Booth #A4409 and
Joe's Garage Bay #4



One Louder

As the band Spinal Tap gets set to make another film, we are reminded that we all want to turn our amps to “11.”

*By Brendan Baker, Editor
BBaker@EndeavorB2B.com*

While browsing my Facebook feed, I was reminded that the movie *Spinal Tap* is one of my all-time favorites. I bring this up now because the part I love and quote often is where Nigel Tufnel (Christopher Guest) tells Rob Reiner that his amp goes to “11,” not ten. “That’s one louder,” he says.

If you’re reading these pages, it’s probably safe to assume you love tools and use them in your professional life. What I love about tools is that each has a different purpose; some have many uses, but all play a role in getting the job done.

Every tech wants that tool to get the job done better. As witnessed in our Big Time Boxes feature, no two tech’s toolbox is the same. We customize our tools to fit our needs.

If your customer wants a custom car with one-off wheels and tires and a custom-built engine, are you really working on that car with your big box store tools? Customers are impressed by a giant toolbox, a shiny set of wrenches, and your knowledge and skill.

In my shop, I have my racing tools separate from other tools. These are the ones that are a specialty for the cars and karts I

race, but also, they are my good, professional tools. They are, in a sense, “one better” than the regular tools I keep at home. And those are not to be confused with the tools I use to work on my house for home improvement projects. I seldom use my car tools for the house. That’s crazy!

I want my tools to have different uses and be stored in separate places – whether in different drawers in the toolbox or a separate toolbox altogether. So when I’m working on my vehicles or doing brake repair jobs for friends and family, I like to have my tools in one place, not mixed in with the paint brushes or putty knives. Tool storage is an issue for those of us with multi-tasking lives.

Our tools are like *Spinal Tap’s* Marshall Amp. The tools we use (and buy) give us the ability to perform at our best. When you feel like you’re not at the highest level, we always want to go one louder and turn it up to 11!

Today’s tools have many more features than the tools of even a decade ago. Think about all of the electronic scanners and digital tools you have in your toolbox today. They offer far more functionality than the tools we used to have.

The boys in *Spinal Tap* may not have realized what they were creating back in 1984. But the One Louder phenomenon has spread far and wide since then in the



YouTube | Mark Jennings

automotive tool industry. So stay tuned for *Spinal Tap II*, which is rumored to be coming out soon to commemorate the 40th anniversary of the first film. Will the amps go up to “12” this time? ❌

PTEN EDITORIAL ADVISORY BOARD

TECHNICIANS

ERIC MOORE,
DeMary Trucks, Columbus, OH
LOU FORT,
K.A.R.S. Inc., Huntingburg, IN

SHOP OWNERS

KIM AUERHEIMER,
Cool Springs Automotive, Brentwood, TN
TANNER BRANDT,
Autodiag Clinic, Welford, SC
PHIL FOURNIER,
Phil’s Auto Clinic, Hemet, CA
JD GOAD,
Goad’s Body Shop, Lexington, VA
EDWIN HAZZARD,
Southeast Mobile Tech, Goose Creek, SC

PETE RUDLOFF,
Pete’s Garage Inc., Newark, DE
MICHELLE TANSEY,
Dubclinic, Santa Clara, CA

EQUIPMENT MANUFACTURERS

KIMBERLY COTTLE
Associated Equipment
JIM O’HARA,
Clare Automotive



FACEBOOK
facebook.com/
ptenmagazine



LINKEDIN
linkedin.com/company/
professional-equipment-tool-news



INSTAGRAM
@ptenmagazine



YOUTUBE
PTEN (Professional Tool
& Equipment News)

LEVEL UP

You need to manage your diagnostics workflow from start to finish. So you need the most advanced information-driven scan and scope device in the industry, with the storage, processing and communications capabilities to get you through every step—designed and built specifically for the automotive industry by a company you're absolutely sure you can trust.

Driven by Fast-Track® Intelligent Diagnostics, the **ZEUS+** provides you with the information you need to diagnose, repair and manage that issue—simplifying your workflow and increasing your efficiency on every job.

It's the only tool on the market that can do that. All to help you level up your game.

snapon.com/zeusplus



Fast-Track® Intelligent Diagnostics.
Available on the APOLLO™, TRITON™ and ZEUS™.

Snap-on®

GET TO KNOW
THE NEW **ZEUS+**

Scan here to
see it in action



Smarter. Faster. **Fixed.**

Snap-on is a trademark of Snap-on Incorporated. All rights reserved. ©Snap-on Incorporated 2022.

Circle 5 on card or click "PTEN e-inquiry" on VehicleServicePros.com

FEATURED NEW PRODUCTS



TORQUE ACCURACY OF ±4 PERCENT

The **CTA Manufacturing Torque Limiting Ratchet Wrench**, No. 8930, has a 25.81 ft-lb pre-set to allow technicians to easily torque down the cartridge-style oil filter housing caps, found in many Asian and domestic vehicles. The 8930 features a blue comfort grip handle to easily identify over the previous version, the 8940, which has a red handle. The 8930 measures 11-1/2" in length, has a 3/8" drive, and an accuracy of ±4 percent.

Circle 6 on card or click "PTEN e-inquiry" on VehicleServicePros.com

ADVANCED NITRILE COATED PALM FOR BETTER GRIP



The **Makita Advanced FitKnit Cut Level 7 Nitrile Coated Dipped Gloves** are ideal for automotive work. The 10-gauge FitKnit material gives users optimal fit and flexibility as well as increased cut protection. The Nitrile coating on palm and fingers is oil and fluid resistant, with advanced coating on the palm for improved grip. The gloves are ANSI-rated cut level A7, puncture level 4, and abrasion level 3 for added durability and protection. The gloves are also touchscreen compatible and machine washable.

Circle 7 on card or click "PTEN e-inquiry" on VehicleServicePros.com

IS SMOKELESS AND VAPORLESS

The **Flo-Dynamics EV Battery Pack Leak Tester**, No. LPLT-100, is a multi-purpose, low-pressure leak tester designed to offer rapid and efficient testing for EV battery pack compartments. The smokeless, vaporless unit provides clean, dry, contamination-free air for testing. The LPLT-100 allows for a technician to connect, test, and provide an accurate leak flow rate on the flow meter. Simply switch the control knob to decay/off to perform pressure decay testing. It uses shop air, is Ford approved, and offers an optional, high-voltage glove adapter for quick and accurate glove testing.

Circle 8 on card or click "PTEN e-inquiry" on VehicleServicePros.com



FOR MORE INFORMATION ON THESE PRODUCTS, CLICK ON "PTEN E-INQUIRY" at VehicleServicePros.com OR CIRCLE THE NUMBER ON THE CARD.

Kicking off the New Products section each month, our Featured New Products page includes brand new products showcased on the cover that are available to the automotive market.



TAKES THE GUESSWORK OUT OF MAKING CAR KEYS

The **XToolUSA Nitrous Key Making System** contains everything a shop needs to immediately begin making car keys. The system is powered by the Triton PLUS key cutting machine and the AutoProPAD G2 car key programmer, both ensuring dependability and reliability. In addition to the hardware, the system includes all of the keys and remotes for the most common vehicle types shops are likely to encounter on the road, in a compact and convenient package. With free online trainings, year/make/model lookup at nitrouskeys.com, and U.S.-based technical and warranty support, the Nitrous Key Making System will quickly introduce a brand new and highly-profitable revenue stream to a shop's bottom line.

Circle 9 on card or click "PTEN e-inquiry" on VehicleServicePros.com

SPONSORED BY XTOOLUSA



IDEAL EV CHARGING STATION FOR BUSINESSES

The **Enel X Way JuiceBox Pro 40** is a Level 2 charging station with all the smart charging features that businesses need to maximize their EV infrastructure investments. Powered by the JuiceNet smart EV charging platform, JuiceBox Pro offers direct administrator control and energy optimization through user-friendly apps and web-based dashboards. The JuiceBox Pro 40 is the ideal EV charging station for businesses that want to provide fast and affordable EV charging services to their customers and employees. The JuiceBox Pro 40 is rated for both indoor and outdoor use and is designed to accommodate installation in a flexible range of locations.

Circle 10 on card or click "PTEN e-inquiry" on VehicleServicePros.com



IMPROVES USER EXPERIENCE

The **Bosch ADS and ADS X 5.0 Software Update** further improves user experience by granting technicians the ability to access module-specific data stream items and special tests directly from the DTC results screen. The update also allows technicians to sort and search saved reports using filters including year, make, model, and other factors. Additionally, users will be able to increase reporting efficiency by accessing more options when conducting a report. Bosch ADS users with a current subscription can install the updates after automatically receiving the download.

Circle 13 on card or click "PTEN e-inquiry" on VehicleServicePros.com



ALLOWS FOR A QUICK, LEAK-FREE REPAIR

The **ProMAXX Tool Cylinder Head Repair Kit** allows technicians to rescue a botched repair where an attempt to drill out a broken exhaust manifold bolt has penetrated the cylinder head. The kit comes packaged in a convenient case with a precision drill bit, tap, locking fluid, Blind ProSert, and insert tool. The Blind ProSert fits into any 8mm bolt hole, used by most automotive manufacturers, including Ford, BMW, GM, Mercedes-Benz, CDJR, Audi, and many others. The Blind ProSert is hardened steel and black-oxide coated for corrosion resistance. The kit is made in the U.S.A.

Circle 11 on card or click "PTEN e-inquiry" on VehicleServicePros.com



CHANGE A COOLING SYSTEM PART WITHOUT DRAINING

The **Matco Tools Cooling System Pressure Tester, Refiller and Retainer**, No. MPT333, creates pressure to pressure test a cooling system. The tool allows the user to change a cooling system component on a vehicle, check the repair by pressure testing, and add coolant or refill the cooling system just by turning valves. By turning a valve, a vacuum can be created to refill a cooling system with coolant. The tool can also create sufficient vacuum flow to retain the coolant in the cooling system while changing a component, so draining the coolant is not necessary.

Circle 14 on card or click "PTEN e-inquiry" on VehicleServicePros.com



HEAT-TREATED FOR STRENGTH AND DURABILITY

The **ATD Tools 14-pc 3/4" Drive 6-Point SAE Deep Impact Socket Set**, No. 64114, is heat-treated for strength and durability. Manufactured using chrome molybdenum alloy steel, the set meets or exceeds ANSI specifications. The set includes sizes: 3/4", 13/16", 7/8", 15/16", 1", 1-1/16", 1-1/8", 1-3/16", 1-1/4", 1-5/16", 1-3/8", 1-7/16", 1-1/2", and 1-5/8".

Circle 12 on card or click "PTEN e-inquiry" on VehicleServicePros.com



ABLE TO LIFT EVS

The **BendPak QuickJack 6000ELX** is a portable car lift that is able to lift EVs for maintenance, service, and detailing. The 6000ELX is a compact, frame-engaging scissor lift with an open-center design for complete access to the vehicle's undercarriage, and has a lifting capacity of 6,000 lbs. Its extra-long frames provide access to lifting points between 47-1/2" to 76". Features pendant controls for one-handed operation, dual-position automatic safety locks, and durable urethane wheels that facilitate rolling the lift where it's needed and putting it away when it's not. When not in use, the lift collapses to 3-1/2" and can hang on a wall or slide under a toolbox.

Circle 15 on card or click "PTEN e-inquiry" on VehicleServicePros.com

SPECIFICATIONS:

Lifting capacity	6,000 lbs
Min. lift point spread	47.5"
Max. lift point spread	76"
Overall frame length	86"

NEW PRODUCTS

INCLUDES FOUR STANDARD NOSEPIECES

The **Marson HP-5 Professional Hand Riveter** from **Howmet Fastening Systems** includes four standard nosepieces to set 3/32", 1/8", 5/32", and 3/16" blind rivets in all alloys. It features a drop-forged steel handle and heat-treated aluminum body with a steel insert, high-quality powder coated finish, and a special alloy steel fulcrum pin with anti-wearing design, plus durable jaws and jaw case.

Circle 16 on card or click "PTEN e-inquiry" on VehicleServicePros.com



ASSURES PROPER PISTON INSTALLATION

The **OTC Piston Ring Compressor**, No. 5852, is designed to assure proper piston installation while reducing the possibility of broken rings. The ring compressor has a diameter of 4.589" and works on select Navistar MaxxForce, N9, N10, and 9000 engines. The product dimensions are 13.4" width by 10.6" depth by 7.5" height, and it weighs 8.9 lbs. The ring compressor is made in the U.S.A.

Circle 17 on card or click "PTEN e-inquiry" on VehicleServicePros.com



REACTIONLESS RATCHET ELIMINATES KICK BACK

The **1211MAX Series High Speed Ratchet** from **Ingersoll Rand** features 80 lb-ft of nut-busting torque and produces 625 rpm of free speed—speeds three times faster than its previous generation. The twin hammer reactionless impact mechanism protects the operator's knuckles and fingers from kick back while completing the job. Once it has reached its torque limit, the operator can add a last touch of torque manually using the tool's true ratcheting mechanism. It weighs just over 3 lb. An ergonomic design with a compact, straight-line composite handle and contoured trigger maximizes comfort, control, and accessibility. Available in 3/8" or 1/2" drive models.

Circle 18 on card or click "PTEN e-inquiry" on VehicleServicePros.com



CAPTURES MATERIALS DOWN TO 0.3 MICRONS

The **Dynabrade Mega-Raptor Vac** is a multi-industry clean air solution with fully integrated features designed to improve an operator's working conditions as well as extend vacuum longevity. Its large 20-gal collection capacity extends time between bag changes, enhancing overall operator productivity and is optimal for a two-operator workstation. Single and dual operator settings assure ample lift and flow performance per operator. Designed only for dry operation, the vacuums offer two-stage filtration that captures materials down to 0.3 microns. It also features built-in overload protection that will shut down the system and a reduced air flow indicator that prompts filter, hose, or bag maintenance.

Circle 19 on card or click "PTEN e-inquiry" on VehicleServicePros.com



UPDATED FOUR-MODE SPEED SETTINGS

The **DeWalt 20V MAX XR 1/2" High Torque Impact Wrench with Hog Ring Anvil**, No. DCF900GP2, delivers up to 1,030 ft-lbs of maximum fastening torque and 1,400 ft-lbs of maximum breakaway torque. Its Precision Wrench mode helps prevent overtightening in forward and run-off in reverse for additional user control. Additionally, the impact wrench features updated four-mode speed settings, a variable speed trigger, and an on-tool LED. It measures 8.8" in length and 9.1" in height, and weighs 6.4 lbs.

Circle 20 on card or click "PTEN e-inquiry" on VehicleServicePros.com

CUSTOMER REVIEW:
“ This impact gun is in a league of its own. This thing has some raw power! ”

FOR ALL TYPES OF EVS

The **Webasto Go Level 2 Mobile EV Charger** comes with region-specific certifications such as UL, cUL, CE, and more. The dual-voltage (120V and 240V) portable EV charger is able to charge all types of EVs, delivering up to 32A. It's engineered to endure harsh outdoor conditions while keeping users safe from electrical hazards. The Webasto Go is designed to meet the highest safety standard with grid plug temperature monitoring and features plug-specific electrical current limitations, automatic adapter detection, and built-in temperature sensing. It has a IP67 rating and includes a NEMA 14-50 grid plug for Level 2 charging and a 120V grid plug for Level 1 charging.

Circle 21 on card or click "PTEN e-inquiry" on VehicleServicePros.com



How do *you* plan to service EV battery packs?

The BendPak EV2400SL is a push-around full-rise scissor lift table that is perfectly suited for EV battery pack replacement. With its compact design, this space-saving scissor lift can be easily transported anywhere in the workplace, making it ideal for multi-bay facilities or workplaces with confined areas. To learn more visit www.bendpak.com/EVLIFT.

NEW

40"

60"



Full-Length Utility Trays

Twin Hydraulic Cylinders

12-Volt Deep Cycle Battery

Oversized Urethane Casters



Hand Pendant Control



Optional Adapters



Battery-Powered Mobility

BENDPAK MODEL
EV2400SL
SPECIALTY LIFT

1-800-253-2363 ■ www.bendpak.com

BP BendPak

© 2022 BendPak Inc. All rights reserved.

Circle 22 on card or click "PTEN e-inquiry" on VehicleServicePros.com



BUILT FOR LIGHTWEIGHT DURABILITY

The **M12 Heated AXIS Jackets and Vests** from **Milwaukee Tool** are designed to deliver heat built for lightweight durability. Redesigned to reach three times faster heat, these heated products utilize lightweight and durable carbon fiber heating elements to bring comfort and warmth to the jobsite. A hidden battery pass-thru pocket construction allows for front or back battery placement, increasing comfort and flexibility depending on the task. With re-engineered AXIS Ripstop polyester fabric and reinforced high-wear zones, the heated AXIS program protects wearers from abrasion and prevents tears from spreading in harsh jobsite conditions.

Circle 23 on card or click "PTEN e-inquiry" on VehicleServicePros.com



USEFUL FOR SMALL PARTS IN BLIND SPOTS

The **Performance Tool Flexible Magnetic Pickup Tool**, No. W83191, is a rigid, yet flexible pickup tool that bends to any position and stays in place. The tool is useful for small parts in blind spots and hard-to-reach places. The flexible aluminum neck with knurled aluminum handle measures 24", and the 1.5 lb capacity magnetic head is 5/16" in diameter.

Circle 24 on card or click "PTEN e-inquiry" on VehicleServicePros.com

NEUTRALIZES ACIDS THAT CAUSE CORROSION

The **Kent Automotive Battery and Terminal Cleaner** is designed to quickly and effectively dissolve corrosion deposits. It neutralizes acids that cause corrosion. It can be used on batteries, terminals, and cables as well as hold downs and battery trays. The aerosol cleaner will not harm paint, rubber, or plastic components, the company says. Comes in a 13.75 oz. can.

Circle 25 on card or click "PTEN e-inquiry" on VehicleServicePros.com



MAXIMUM LIFTING HEIGHT OF 78"

The **Danmar D4-12A Alignment Lift** can be used to perform two- or four-wheel alignments and general service work on cars, SUVs, and light trucks weighing up to 12,000 lbs. The ALI-certified lift comes with free-floating, heavy duty turnplates and rear slip plates built into the runways for maximum convenience. The lift has a maximum lifting height of 78" and features an automatic leveling system with multiple auto-leveling locking positions in each column and a push-button safety release. The non-skid runways adjust for various tread widths. The D4-12A runs on an electric/hydraulic power system with a single hydraulic cylinder mounted under a runway for convenience and protection.

Circle 27 on card or click "PTEN e-inquiry" on VehicleServicePros.com



REUSABLE 60 MICRON SCREEN FILTER

The **G-TEC Heavy Duty High Flow Heated Flusher**, No. TTCF-9B, is designed to flush and clean transmission coolers and lines or any hydraulic system of contamination, sludge, and varnish deposits, and particles from a failed transmission. The TTCF-9B has a flow rate of 8 gpm to clean heavy duty transmission cooling systems requiring high flow rates. Using the same hydraulic fluid as the hydraulic system being flushed and cleaned, select from two preset air injected scrubbing action flush patterns, or perform a manual flush. Check system cleanliness with the reusable 60 micron screen filter. The TTCF-9B also has a preset heater that heats to 140 degrees F in 45 minutes.

Circle 26 on card or click "PTEN e-inquiry" on VehicleServicePros.com

SPECIFICATIONS:

Lifting capacity	12,000 lbs
Min. 4-wheel alignment	106"
Max. 4-wheel alignment	158.5"
Max. 2-wheel alignment	163.5"
Max. lifting height	78"

HARNESSES THE POWER

INTRODUCING THE MOST
INTELLIGENT YET AFFORDABLE
DIAGNOSTIC TOOLS EVER UNLEASHED!



OTOFIX IM1

- KEY PROGRAMMER
- DIAGNOSTICS TABLET
- SERVICE RESETS

OTOFIX D1

- BIDIRECTIONAL FUNCTIONALITY
- DIAGNOSTICS TABLET
- SERVICE RESETS

OTOFIX BT1

- BATTERY TESTING
- ELECTRICAL SYSTEM ANALYSIS
- DIAGNOSTICS & SERVICE RESETS

OTOFIX™

WWW.OTOFIXTECH.US ○ @OTOFIXTOOLS





ADDED SUPPORT FOR MODEL YEAR 2022 VEHICLES

The **Bartec TPMS Software Update 64.0** is available for Tech500, Tech300Pro/Pro C, and Tech400Pro tools, and software version 4.0 is for Tech450Pro, Tech550Pro, Tech600Pro, and TechRITEPro tools. The latest version offers added support for model year 2022 vehicles, RITE-SENSOR coverage for Hyundai and Kia vehicles, BartecXD coverage (new Ford and GM OBD-II protocols), 902 MHz coverage for key fob testing, and more placard coverage, including coverage for the new Ford pickups. Additionally, it includes Bartec's TPMS Retro Fit Kit setup functionality.

Circle 29 on card or click "PTEN e-inquiry" on VehicleServicePros.com



SUITABLE FOR THOSE WITH ULTRA-SENSITIVE FEET

The **Hobart Safety Boot** from **Steel Blue Boots** is a men's, 6" elastic-sided, slip-on ankle boot. The boot participates in the American Diabetes Association Better Choices for Life program and is suitable for those with ultra-sensitive feet, needing additional comfort and protection. Crafted from premium, full-grain cowhide leather, the Hobart features a 200 joule safety steel toe cap (ErgoDefender) for ideal protection. The boot is easy to put on and remove, and is more suited to less intensive work that doesn't require additional ankle support. Now available in oak or black.

Circle 30 on card or click "PTEN e-inquiry" on VehicleServicePros.com



HAS A TEST RANGE OF 1MA TO 60A DC/AC

The **High Accuracy Low Current Clamp Meter**, No. 683, from **Electronic Specialties** was developed with new circuitry designed to maximize low current accuracy and zero stability. The clamp is able to measure parasitic drains accurately, efficiently, and with dependable/repeatable readings. It features a 1mA low reading resolution and can read up to 60A. The 16mm x 18mm clamp opening is large enough to clamp over most negative battery cables. The 683 reads both DC and AC currents, and it detects the current automatically. The clamp can also record up to 99 records for recall later. Unit comes with zippered storage case, manual, and 9V battery.

Circle 33 on card or click "PTEN e-inquiry" on VehicleServicePros.com

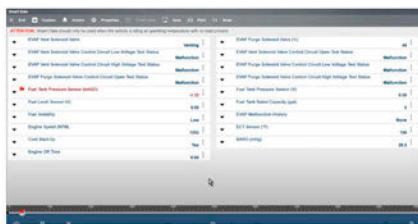

FEATURES CLEAR VIEW FLAG TRACKER

The latest **Snap-on ZEUS Diagnostic Tool Software Update** allows technicians to spot intermittent glitches and to quickly hone in on the root cause of a problem by using the new clear view flag tracker found on the ZEUS diagnostic tool's data graph

view. With the flag drop function, simplified navigation, and updated graph view format, this feature is designed to speed up and simplify the diagnostic process.

Circle 31 on card or click "PTEN e-inquiry" on VehicleServicePros.com

PNEUMATICALLY POWERED WITH FOOT PEDAL CONTROLS

The **Tire Mechanics Resource Air Operated Tire Spreader** is designed to provide a stable platform to complete all types of tire repair work, including tire inspection, cutting, buffing, cleaning, patching, and more. With fully adjustable clamping arms, the tire spreader is built to handle a variety of tires. Pneumatically powered operation with foot pedal controls, the tire spreader will hold the bead and sidewalls during inspection and/or repairs. The Air Operated Tire Spreader is adjustable in five stages with a maximum enlargement 13.8", and includes an adjustable light and attached tool pan.

Circle 32 on card or click "PTEN e-inquiry" on VehicleServicePros.com



BREAKS LOOSE STUBBORN CRANK BOLTS

The **OEMTOOLS Heavy Duty 9mm Crank Bolt Socket**, No. 25290, is designed to easily break loose stubborn crank bolts. Constructed with heat-treated, durable chrome molybdenum steel, the heavy duty impact sockets have more mass for high-torque applications. The socket has a 1/2" drive.

Circle 34 on card or click "PTEN e-inquiry" on VehicleServicePros.com



FOR MORE INFORMATION ON THESE PRODUCTS,
CLICK ON "PTEN E-INQUIRY"
at VehicleServicePros.com
OR CIRCLE THE NUMBER ON THE CARD.



REMOVES QUICK CONNECT WITH SNAP/SIDE LOCK COUPLERS

The **Cal-Van Tools Adjustable Jaw Fuel Line Pliers**, No. 68800, are designed to disconnect fuel, EVAP and breather, push-style quick connect fittings. Can also be used on some electrical connectors. Features a spring-loaded handle with a 2-3/8" maximum jaw spread in the straight position and a 1" maximum spread in the 90-degree position. The 2" long, tapered jaws rotate 180 degrees and have 1/8" contact points. The pliers are suitable to use on multiple vehicles.

Circle 35 on card or click "PTEN e-inquiry" on VehicleServicePros.com



SHOCKS TIE ROD ENDS LOOSE

The **ESCO Heavy Duty Tie Rod End Remover - Commercial Set**, No. 40315, comes with five individually marked tie rod end sockets that are designed to shock tie rod ends loose without damaging threaded areas, rubber seals, or oil nipples. Each socket is manufactured to withstand rigorous use in a professional environment and comes in a fitted case for easy storage. Each socket features a corrosion-resistant black oxide finish and can be used with up to a 1" impact tool. Set includes: 1/2"-20, 7/8"-14, 3/4"-16, M20 x 1.5, M16 x 1.5.

Circle 36 on card or click "PTEN e-inquiry" on VehicleServicePros.com

NEW PRODUCTS



IDEAL FOR ALL PAINT TYPES

The **Wizards Products Select Pro System Line** is designed for the professional body shop. The line is ideal for all paint types and clears, fresh or aged, and is easy to clean up. The Extra Cut rubbing compound is Wizards most aggressive compound. It removes P1200 and finer sandscratches. The Cut and Polish machine polish removes compound swirl marks and produces a high gloss finish while the Ultra Fine machine finish removes fine swirls and shows quality gloss on black.

Circle 37 on card or click "PTEN e-inquiry" on VehicleServicePros.com



CAT COMPLETE™ Fuel, Exhaust & Emissions System Cleaner

Innovation in a bottle.

Within one year, this product has become a worldwide bestseller.

- Complete Fuel, Exhaust & Emissions Cleaner
- Cleans & Restores Catalytic Converter
- Increases power, performance, mileage and saves gas by not only cleaning the entire emissions & exhaust system, but the fuel system as well. Works with gasoline, ethanol and hybrid vehicles.
- Regular use every 5,000 miles optimizes fuel, emissions and exhaust systems, keeping them clean and preventing any Check Engine Lights (CELs). This also saves on expensive fuel system and emission control repairs.
- Pass Emissions Smog Test, Guaranteed

cel-reset.com



- ✓ RESTORE POWER & PERFORMANCE
- ✓ PASS EMISSIONS SMOG TEST
- ✓ DEODORIZES SMELLY EXHAUST



**CAT COMPLETE™
FUEL,
EXHAUST &
EMISSIONS
SYSTEM
CLEANER**

CHECK ENGINE LIGHT MEDIC™
Pass Emissions Smog Test, Guaranteed

- Turn Off Check Engine Light
- Clear P0420 & Other OBD Codes*
- Cleans & Restores Catalytic Converter
- Reduces Emissions & Saves Gas

16.9 FL. OZ. (500 mL)

Part #4720

Circle 38 on card or click "PTEN e-inquiry" on VehicleServicePros.com

NEW PRODUCTS



INCLUDES A TWO-POSITION BODY CLIP

The **Fenix Lighting PD25R Rechargeable Flashlight** produces a maximum 800 lm from an included 16340 rechargeable Li-ion battery. The flashlight features a tail cap switch for on/off and a momentary-on function, and a side switch on the head for mode selection. It offers five brightness levels, plus a strobe. The two-position body clip holds the light securely to a pocket. The PD25R measures 3.62", is IP68 rated for dust and water, and includes a battery, charging cable, lanyard, two spare O-rings, and a body clip.

Circle 39 on card or click "PTEN e-inquiry" on VehicleServicePros.com

CUSTOMER REVIEW:
 "I especially love the external charging port. There's a rotating ring that covers the port and you twist it one full rotation to expose the port. Awesome feature."



DESIGNED TO INSTALL CRANKSHAFT REAR OIL SEAL

The **OTC Rear Seal Installer**, No. 5853, is designed to install crankshaft rear oil seal and wear sleeve on select Navistar, MaxxForce, N9, N10, and DT engines. The kit includes a 180mm adapter ring for 2010 and later engines. The installer features a crank adapter, seal pusher, thrust bearing, installation nut, depth adapter, and two head screws. Made in the U.S.A.

Circle 41 on card or click "PTEN e-inquiry" on VehicleServicePros.com



DELIVERS UP TO 50A

The **Schumacher Electric EV Level 2 Charger** delivers up to 50A, and it's configurable to a full range of amperages. The EV Level 2 charger adds up to 60 miles of range per hour and features 240V for faster charging. The charger is available in hardwired and plug-and-go options, and contains a 25' cable with built-in cable management and a SAE J1772 connector. Additionally, it's Wi-Fi and Bluetooth compatible, has a low-profile design, and offers durable rain tight housing.

Circle 40 on card or click "PTEN e-inquiry" on VehicleServicePros.com



FOR PRYING CAR INTERIOR PANELS

The **Lisle Corporation Double-Ended Trim Remover**, No. 35470, is ideal for prying car interior panels. The heat-treated, alloy steel tool features hardened tips to provide strength and access to panels in tight areas. Double-ended tool with radius on one end and narrow square tip on the other end.

Circle 42 on card or click "PTEN e-inquiry" on VehicleServicePros.com



AVAILABLE IN 110V AND 220V

The **Killer Tools Deluxe Steel Dent Puller with Ergonomically Designed Seated Cart**, Nos. ART38Special-110DX and ART38Special-220DX, are designed to put the technician in the ideal position to repair the majority of dents. The deluxe unit adds two seat level storage trays, lever pulling, and weld key pulling capabilities to the company's original steel dent pullers. The deluxe dent pullers are available in 110V and 220V, and come with a voltage conversion kit to fit the requirements of the user. Complete with steel electrode dent puller, seated cart, two storage trays, lever puller + electrodes, slide hammer + electrodes, shrinking/wiggle wire electrode, wiggle wire, key weld electrode, weld keys and key bar, and pulling claw. Made in the U.S.A.

Circle 43 on card or click "PTEN e-inquiry" on VehicleServicePros.com



COMPATIBLE WITH ALL POWER STEERING FLUIDS

The **Rislone High Mileage Power Steering Stop Whine with Leak Repair** is designed to be a quick and dependable solution for steering "whine," sluggish steering, or a power-steering system leak in high-mileage cars, SUVs, and light trucks. It's formulated to stop bearing, piston, and valve noises inside the power-steering pump. Special lubricity additives smooth out rough, hard, and tight steering and reduce friction. It also renews worn rack and pinion, stabilizes power steering fluid, and protects the steering system against future wear and leaks. Compatible with all types of domestic and imported power steering fluids, including petroleum and synthetic formulas, and works with systems that use ATF automatic transmission fluid.

Circle 44 on card or click "PTEN e-inquiry" on VehicleServicePros.com



FOR MORE INFORMATION ON THESE PRODUCTS,
CLICK ON "PTEN E-INQUIRY"
at VehicleServicePros.com
OR CIRCLE THE NUMBER ON THE CARD.

NEW PRODUCTS 



FEATURES A SPRING RATCHET LOCKING MECHANISM

The **Platinum Tech 2-pc Combination Internal and External Snap Ring Pliers Set**, No. PLT-99911, features a spring ratchet locking mechanism that securely holds against snap ring tension, a thumb release that allows for smooth and controlled tension release, and a cushion grip for comfort. The internal ring size ranges from 3-1/16" and 6-1/4" (78mm - 159mm), and the external ring size ranges from 3-1/2" and 6-1/2" (89mm - 165mm). The tip sizes are .120", 0 degrees, 45 degrees, and 90 degrees, and are replaceable. Made in the U.S.A.

Circle 45 on card or click "PTEN e-inquiry" on VehicleServicePros.com



REPAIRS HEADLIGHT TABS AND OTHER PLASTIC PARTS

The **Polyvance Blockhead Welding Tip**, No. 6032, is designed to work with the company's airless plastic welders to aid in the repair of headlight tabs and other plastic parts. The Blockhead tip is small and narrow, with sharp edges ground into each face to allow the technician to reach into tight spaces and sharp corners. The tip can also be used to repair the "boss tabs" that hold mounting clips on the backside of bumper covers and trim pieces. Made in the U.S.A. with lead-free bronze for high temperature strength and long-lasting use. Its 12-24 NPT thread fits all Polyvance airless heating elements.

Circle 46 on card or click "PTEN e-inquiry" on VehicleServicePros.com

DELIVERS 1,200 CRANKING AMPS

The **Weego 120 Jump Starter** delivers 1,200 cranking amps and features a bypass button that allows users to jump a completely dead battery. It's rated for all gas engines and diesel engines up to 15L. With the included 30" detachable clamps, users can access remote batteries and posts more easily. The Weego 120 can also detect low voltage and provide support to raise and maintain the voltage of a vehicle's 12V battery to a level safe for jump starting. It also doubles as a portable power source for recharging USB devices and 12V tools. The reinforced case is IP65 rated for water, dust, and dirt resistance.



Circle 47 on card or click "PTEN e-inquiry" on VehicleServicePros.com



INCLUDES REDESIGNED SOFTWARE INTERFACE

The **John Bean B2000P Wheel Balancer Update** includes a redesigned software user interface to improve functionality and performance. Enhancements to the B2000P interface include the automatic data entry feature that automatically detects all wheel dimensions, resulting in an automatic selection of the balancing mode, weight type and positions. Another key element is its laser 3D surface mapping, which utilizes a high-resolution camera and laser-based technology to provide sidewall analysis, as well as depth, wear, and tire surface abnormalities that are displayed in an easy-to-read format. Additionally, the optiLine software interface suggests the optimal location for each wheel in the set based on a predetermined set of criteria.

Circle 48 on card or click "PTEN e-inquiry" on VehicleServicePros.com



DIRECT INTEGRATION WITH ADVANCEPRO

The latest **Tekmetric's Shop Management System Update** offers a direct integration with Advance Auto Parts' AdvancePro, allowing Tekmetric users to order parts through their existing AdvancePro account. Through the integration, Advance Auto Parts and Tekmetric provide easy access to affordable, quality products. In one screen, shop owners can receive real-time updates on available parts and quantities, track shipping, and utilize paperless invoices. When purchasing parts, the system automatically utilizes a shop's existing labor guide and parts matrix. For shops that have previously used AdvancePro, the integration looks exactly like the existing system – with the added capability of integrating purchases into Tekmetric for an all-in-one experience.

Circle 49 on card or click "PTEN e-inquiry" on VehicleServicePros.com

NEW PRODUCTS



FOR MORE INFORMATION ON THESE PRODUCTS,
CLICK ON "PTEN E-INQUIRY"
at [VehicleServicePros.com](https://www.VehicleServicePros.com)
OR CIRCLE THE NUMBER ON THE CARD.



COMPATIBLE WITH ALL EV AND HYBRID PLUG-IN VEHICLES

The **Autel MaxiCharger AC Wallbox Home**, No. MC50AHS, is a 240V-50A Level 2 smart charger compatible with all EV and hybrid plug-in vehicles. It features a contemporary design in dark gray and is installable indoors or outdoors. The unit offers adjustable charging up to 50A and features a 25' long universal (J1772) charging cable and hardwire installation. Use the Autel Charge app to customize your charging experience, including remotely starting and stopping, and scheduling charge. Wi-Fi, Bluetooth, and ethernet connectivity options available.

Circle 50 on card or click "PTEN e-inquiry" on [VehicleServicePros.com](https://www.VehicleServicePros.com)



STRETCHES UP TO 12.8"

The **Titan Professional Tools 3/8" Drive Extendable Ratchet**, No. 12069, stretches up to 12.8" for added leverage and collapses to a compact 8.5" for work in confined spaces. The spring-loaded ring locks the handle into four positions, and the low profile flat head keeps dirt out. Features a knurled handle for a sure grip. The ratchet is made out of forged chrome vanadium alloy steel construction and has been heat-treated for durability and strength. The 72-tooth, reversible ratchet provides 5 degrees of handle swing. With a fully polished chrome finish, the ratchet easily wipes clean of oil and dirt.

Circle 53 on card or click "PTEN e-inquiry" on [VehicleServicePros.com](https://www.VehicleServicePros.com)



PROTECTS AGAINST IMPACT AND COMPRESSION

The **Cat Footwear Exposition 6" Alloy Toe Work Boot** protects against impact and compression, offering the strength of a steel toe in a lightweight and compact format due to the cement construction. The durable rubber outsole provides comfort for walking all day long. The SRX slip-resistant rubber outsole is abrasion resistant, performs against oil and water, and provides traction on slippery surfaces. The electrical hazard protection is rated to protect against open circuits up to 600V in dry conditions. Available in black or pyramid and in men's sizes seven to 14.

Circle 51 on card or click "PTEN e-inquiry" on [VehicleServicePros.com](https://www.VehicleServicePros.com)



FEATURES A DOUBLE PUMP DESIGN

The **Ascot Supply 3.5-Ton Floor Jack** features a double pump design that allows for quick lifting and improved efficiency. The floor jack is low profile, enabling it to fit in narrow spaces. Its heavy steel construction provides maximum durability. The 3.5-Ton Floor Jack is also equipped with a foot pedal for handsfree positioning. The floor jack has a lift range of 3-3/4" to 21-3/4" and includes a one-year limited warranty.

Circle 52 on card or click "PTEN e-inquiry" on [VehicleServicePros.com](https://www.VehicleServicePros.com)

IDEAL FOR NVH BALANCING APPLICATIONS



The **Pico Technology PQ316 PicoBNC+ Optical Sensor Kit** provides users with a convenient means to capture rotational speed reference signals for noise, vibration, and harshness (NVH) balancing applications with the benefits provided by Pico Technology's PicoBNC+ smart interface technology. The PQ316 PicoBNC+ optical kit can be partnered with an NVH kit and a PicoBNC+ Automotive PicoScope to help users detect propshaft (drive shaft) vibrations.

It can also support speed measurement of other rotating items. The PQ316 kit includes the TA497 PicoBNC+ optical sensor and a PicoScope magnetic mount.

Circle 54 on card or click "PTEN e-inquiry" on [VehicleServicePros.com](https://www.VehicleServicePros.com)

NOW AVAILABLE IN GREEN AND YELLOW

The **Cornwell Quality Tools blueION COB Skinny Rechargeable Worklight** is now available in green and yellow. The 1/2" ultra thin light emits three-way light functions: Full power (500 lm), half power (250 lm), and a SMD top light (65 lm). The light has a three hour run-time on full power and six hours on half power. The swivel magnetic accessory allows for the light to be mounted to metal surfaces. The light also has a direct plug to recharge via a type-C USB, is IP66 rated, and has overcharge and over discharge protection.

Circle 55 on card or click "PTEN e-inquiry" on [VehicleServicePros.com](https://www.VehicleServicePros.com)

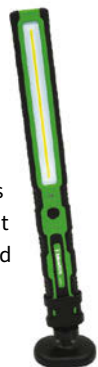

Electronic controls: Lateral and longitudinal

Electronic controls have displaced many of the mechanical systems we once saw on vehicles years ago.

By **Scott Brown**, PTEN Technical Editor



▲ Figure 1 - ADAS vehicle in operation, path planning to avoid a VRU

Electronic controls have displaced many of the mechanical systems we once saw on vehicles years ago. Electronic throttle and steering are popular these days, but we're now seeing vehicles with systems such as electromechanical brake boosters, electric power steering executing lane changes, avoiding vulnerable road users (VRU), and more. This article will discuss service operations diagnostics surrounding these systems.

ADAS

Advanced driver assistance systems (ADAS) have been populating the vehicle beginning as far back as 2010, supporting SAE's J3016 Level 0 vehicles which, for the most part, only offered visual and/or audible warnings to the vehicle operator when an unsafe condition

was detected. Moving into higher levels (1 and 2) requires additional support via advanced electronic control systems supported by critical communication channels as shown in **Figure 1**. Technicians looking to stay ahead of the curve know that continuing education is an absolute must to stay service ready. Professional service providers possessing a deeper understanding on these systems will typically result in "less-friction" for the service technician during diagnostics and service.

THROTTLE ACTUATOR CONTROL (TAC)

For more than two decades, electronic throttle bodies have been populating the vehicle market, and I suspect that your customers have seen more than a few with intermittent DTCs related to the throttle actuator. The device usually consists of a DC motor and two throttle position sensors that typically, but not always, output 



somewhat opposing signals, which are used to validate proper system operation. The DBW system took on a lot of heavy risk assessment study and had to pass through the Automotive Safety Integrity Level (ASIL) steps before standards for design and implementation could be approved. Generally, these systems have provided vehicle manufacturers additional tools that can be used to enhance vehicle performance, achieve emission compliance, minimize drivetrain wear, and maintain overall safe vehicle operation.

SCOPING THE PROBLEM

Service technicians dealing with intermittent faults on such systems should be aware that the safety engineers, as per safety requirements, must deploy a series of safety checks on the TAC systems before any propulsion torque commands can be issued to the vehicle. What this means is that upon key up or vehicle wake up, the system will run routines designed to validate the integrity of the system. The state of health checks may include RAM/ROM/EEPROM tests, analog-to-digital conversion tests, mechanical performance tests, shutdown tests, and so on. When a technician is dealing with a suspect throttle body, they may consider taking a deeper look at the throttle body using a digital storage oscilloscope (DSO), such as shown in **Figure 2**.

Techs interested in seeing a self-test in operation can use their DSO to analyze this. Two channels can be used to log both throttle position sensors, and an amp current probe can be used on one of the motor circuits. The image shown in Figure 2 is from a 2004 GM V8 application, which was setting a P0120 (TP1 Circuit) and a P2135 (TP 1-2 Signal Correlation). The time shown between the cursors equals 486ms, which was captured at key up.

Figure 3 zooms in to the first 26ms of activity, where I observed what appeared to likely be a mechanical interference condition of the throttle plate, which was affecting both TP signals. The throttle body was extremely coked up with carbon and since it had over 200,000 miles on it, we recommended replacement over cleaning.

After replacement of the throttle body, I proceeded to collect a comparison DSO trace, so I could see what a new, known-good throttle body would look like during the same key-up self-test. **Figure 4** shows a properly operating system.

I have collected dozens of images like this and have seen some that helped me to identify high commutator resistance on a brushed DC motor that I could not get to exhibit the symptoms described by the vehicle owner to appear while it was in the shop. However, the scope was able to provide me with some additional data points I then used to reinforce my recommendations for component replacement.

BRAKING SYSTEMS

With the introduction of anti-lock braking (ABS), we've seen quite a few new pieces of hardware occupy the vehicle. Today, we're seeing more and more alternative propulsion systems, such as hybrids and battery electric vehicles (BEVs) populating the fleet. With this new technology comes significant changes with the operational characteristics of the vehicle, often demanding other vehicle control methods.

Since hybrid and battery electric vehicles can take advantage of converting vehicle kinetic energy into electrical energy, additional engineering produced methods to reduce speed without much expense in brake wear. Therefore, you tend to see less brake wear on such vehicles if the vehicle is being operated properly.

RELATED PRODUCTS



Pico Technology

PicoScope,
Nos. 4425A & 4225A

Circle 56 on card, or click "PTEN e-inquiry"
on VehicleServicePros.com



Electronic Specialties

Super Relay Buddy, No. 194

Circle 57 on card, or click "PTEN e-inquiry"
on VehicleServicePros.com



Power Probe Group

Volt Tester,
No. VT750LCD

Circle 58 on card, or
click "PTEN e-inquiry"
on VehicleServicePros.com





FOR MORE INFORMATION ON THESE PRODUCTS,
CLICK ON "PTEN E-INQUIRY"
at VehicleServicePros.com
OR CIRCLE THE NUMBER ON THE CARD.

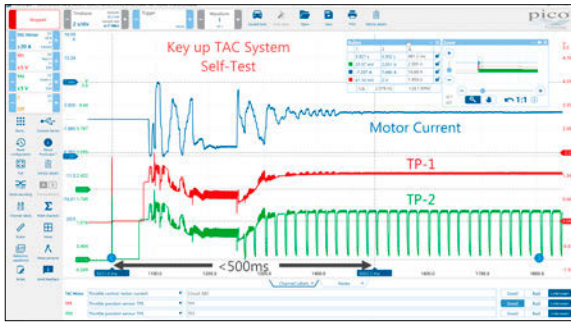

▲ Figure 2 - Key-up TAC system self-test

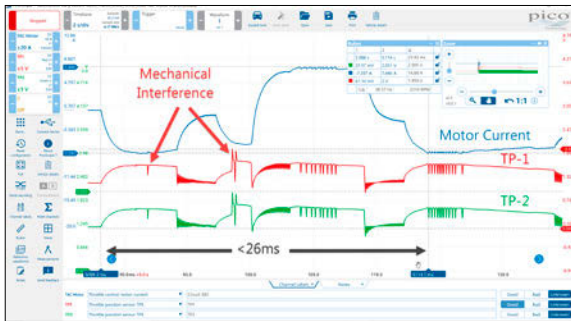

▲ Figure 3 - Key-up TAC system self-test, zoomed

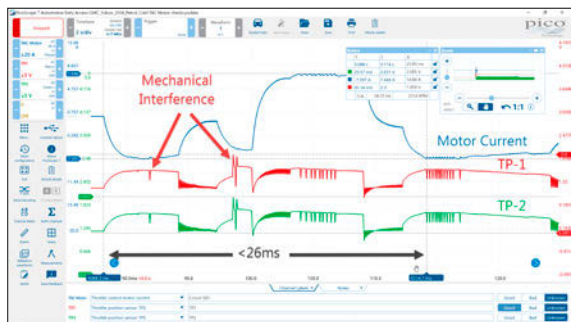

▲ Figure 4 - Key-up TAC system self-test, zoomed with new throttle body

On the internal combustion engine (ICE) side of the propulsion systems found on hybrids and extended range vehicles, engine vacuum was no longer abundantly available to supply the traditional power brake booster. This required either the addition of an electric vacuum pump or a complete redesign of the braking system. Looking back at the Toyota Prius, they relied on an electric pump to multiply the braking force applied to the brake pedal using a hydraulic pump and accumulator and in-turn, had to deploy a stroke simulator to provide the proper pedal feedback to the driver.

As the driver increases pedal force, elevated pressurized brake fluid is applied to all four-wheels programmatically (other manufacturers may deploy different methods for brake assist). When working on these systems, one should always follow the manufacturer's recommendations, so these electronically controlled systems are always

AUTEL®

THE FUTURE OF
DIAGNOSTICS IS HERE

ULTRA



12.9" SCREEN / ANDROID 7

FIVE-IN-ONE VCM1

- OSCILLOSCOPE
- MULTIMETER
- NEW PROTOCOLS



**TOPOLOGY
MODULE MAP**

- ALL SYSTEM STATUS SCREEN
- COLOR CODED FAULTS

INTELLIGENT DIAGNOSTICS

- REPAIR ASSIST
- GUIDED DIAGNOSTICS



SUPPORT: 1.855.288.3587

EMAIL: USSUPPORT@AUTEL.COM | WEB: AUTEL.COM

VIEW MARKETING MATERIAL: ISSUU.COM/AUTEL2

FOLLOW US @AUTELTOOLS

Circle 59 on card, or click "PTEN e-inquiry" on VehicleServicePros.com



▲ **Figure 5 – The GEN 2 iBooster from Bosch**

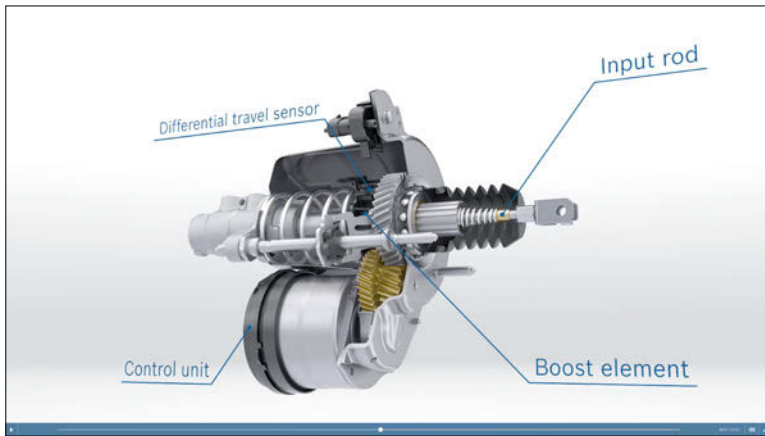

▲ **Figure 6 - The iBooster provides the power assist through its internal brushless DC motor**

ready to work at their full potential. Look for notices within the service information to execute the proper relearning/recalibration steps prior to returning the vehicle back into operational status.

The following is a notification found within Toyota’s factory service information braking section after replacing the brake booster/master cylinder on a 2020 Prius:

NOTICE: After replacing the skid control ECU (brake booster with master cylinder assembly), perform linear solenoid valve offset learning, ABS holding solenoid valve learning, yaw rate, and acceleration sensor, zero-point calibration and system information memorization after performing “Reset Memory”.

The Bosch iBooster (**Figure 5**) is a vacuum independent, electromechanical brake booster. Currently, there are two generations of the iBooster being used by multiple manufactures, including GM, Honda, Jaguar, Porsche, Tesla, and VAG. The unit can deliver varying brake pedal feel (selectable by the driver) and can greatly enhance the operational characteristics of hybrid/BEVs and offer even more assistance for vehicles equipped with certain ADAS features, such as adaptive cruise control (ACC) with stop-n-go support. The iBooster has an integrated control module and provides the power assist through its internal brushless DC motor, as shown in **Figure 6**.

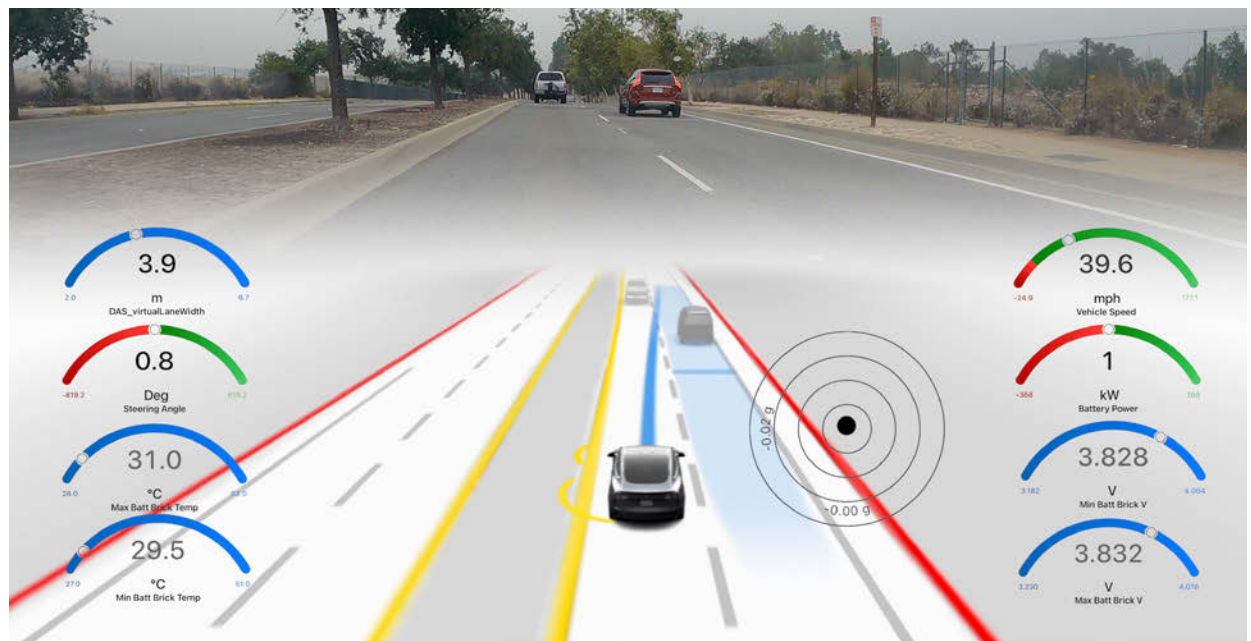

▲ **Figure 7 - Vehicle with active lane change assist**

ELECTRIC POWER STEERING (EPS)

Although the first implementation of a full-control electric rack and pinion assist surfaced in 1990, this method wasn't widely adopted until the early 2000s. Again, the reason for moving to electric assist is because of the energy efficiency it brings to both ICE and BEVs, but it also allows more options, especially for those offering driver assistance features such as lane tracing/keeping assist (LTA/LKA) and active lane change assist (LCA) (Figure 7). EPS on some vehicles will nudge the vehicle back into the center of the lane when it determines that the vehicle is about to drive over clearly defined lane markings.

On some SAE J3016 Level 2 vehicles, automated lane changes can be achieved by the system. If you have driven a vehicle that can execute such a maneuver, I suspect that you admire the technology like I do. It's amazing to see a vehicle pull this off successfully.

SERVICE AND DIAGNOSTICS

Although these systems may appear to be complicated, with the appropriate training, service information, and tooling, the service professional can work through any challenges presented. The key here in my opinion is to make sure that service personnel have an increased situational awareness of the service requirements of vehicles equipped with these systems (and the proper tools for the job). Services such as brake fluid replacement and wheel alignments aren't so basic anymore, as these systems will likely require follow-up procedures to ensure the vehicle is operating to its full potential.

Additionally, it's important these vehicles are always operating with a sound electrical system and that starts with the 12V battery. Performing periodic battery inspections can go a long way toward preventing trouble from surfacing in these advanced systems. For the service technician tasked with performing diagnostics on any of these systems, a highly capable scan tool is essential during interrogation.

However, you may find that certain tasks may only be available using the OEM scan tool, and your mileage may vary. In other cases, you'll likely need a DVOM, breakout leads, test probes, current probes, breakout boxes, a DSO, and possibly CAN tools when you're up against something that falls outside of the diagnostic flow chart. See the case study featured in my article titled, "Vehicle network diagnostics: Today and the future" at vehicleservicepros.com/21209167.

The evolution of the automobile is not slowing down, and in fact, has accelerated quite a bit over the past five to eight years. Service professionals that keep up with these technologies are in high demand and will be highly valued for years to come in my professional opinion. ❌



SCOTT BROWN is an ASE Master Certified L1 Technician and has over 37 years of professional service industry experience. He is an independent shop owner in Southern California and is engaged at various levels within the industry. He has a deep understanding of the challenges technicians experience at the service level and is continuously striving to move the industry forward through education and networking. Brown founded Diagnostic Network (diag.net) after 22 years of service at iATN, where he retired as company president in 2018.

SBrown@VehicleServicePros.com

AUTEL® REMOTE EXPERT

REMOTE SERVICES. EASY COMMUNICATION.
INTELLIGENT OPERATION.

SHOP TECHS REMOTELY CONNECT WITH AN EXPERT
MODULE PROGRAMMING

SAVE TIME & MONEY

ONLINE & ALWAYS READY



WATCH VIDEO NOW

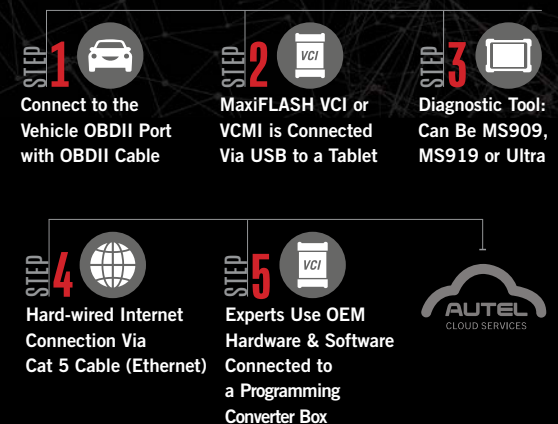

CLOUD.AUTEL.COM/EXPERT



SUPPORT: 1.855.288.3587
EMAIL: USSUPPORT@AUTEL.COM | WEB: AUTEL.COM
VIEW MARKETING MATERIAL: ISSUU.COM/AUTEL2
FOLLOW US @AUTELTOOLS

Circle 60 on card, or click "PTEN e-inquiry" on VehicleServicePros.com

Built to Last

2500 SERIES

14 GA
FRAME / 18 GA
DRAWER



The 2500 series was built to be a powerful workhorse offering uncompromising durability and space that will last a professional for a lifetime.

This series is offered in three sizes (72", 54" & 41") with coordinating top-chest, hutch, stainless and butcher-block work surfaces available. Two color choices (Reflex Blue and Jet Black).

Circle 61 on card or click "PTEN e-inquiry" on VehicleServicePros.com

3500 SERIES

14 GA
FRAME / 16 GA
DRAWER



The 3500 series line of toolboxes was built to with the intent to last a lifetime, but we decided to take that one step further and built it to last for generations. The 3500 series is backed by an outstanding lifetime transferable warranty.

The 3500 series is offered in two sizes (72" and 60") and color choices (Reflex Blue and Jet Black). Complete your setup with the optional coordinating pneumatic assisted top-chest or hutch, matching side cabinet or locker. Stainless steel and butcher-block work surfaces are also available.

A look at network diagnostic tools and strategies

When diagnosing automotive network buses, the age of the vehicle will be a major player in which tool you are going to be using.

By **Ross Colketf**, Contributing Editor

Our shop is known for our diagnostic abilities in the local area. Being confident in our abilities has much to do with the capabilities of our tools, and the know-how to exploit them. As such, we get many vehicles in to diagnose network communication issues.

We see everything from bad wiring to bad modules on these vehicles, and sometimes as simple as a missing fuse. However, one technique that is common among all that we encounter is beginning our network diagnostic process with an in-depth interview with the customer.

THE BEGINNING OF THE DIAGNOSTIC JOURNEY

We try to gather as much information as possible to duplicate the customer's concern. We will then pull trouble codes from the entire vehicle. We prefer to use the Autel Ultra as it will also give us a network topology map of the vehicle's communication systems (**Figure 1**).

Note: I do recommend consulting service information for the accuracy of the topology map as I have seen occasional errors with the maps. This includes both the information systems and scanners having errors. Sometimes, you will have to compare the vehicle to each topology map to determine which one is correct.

We will then check the vehicle service information, TSBs, and Identifix for similar problems. I will not use Identifix as the "silver bullet," but rather as guidance to a possible resolution (**Figure 2**). We then

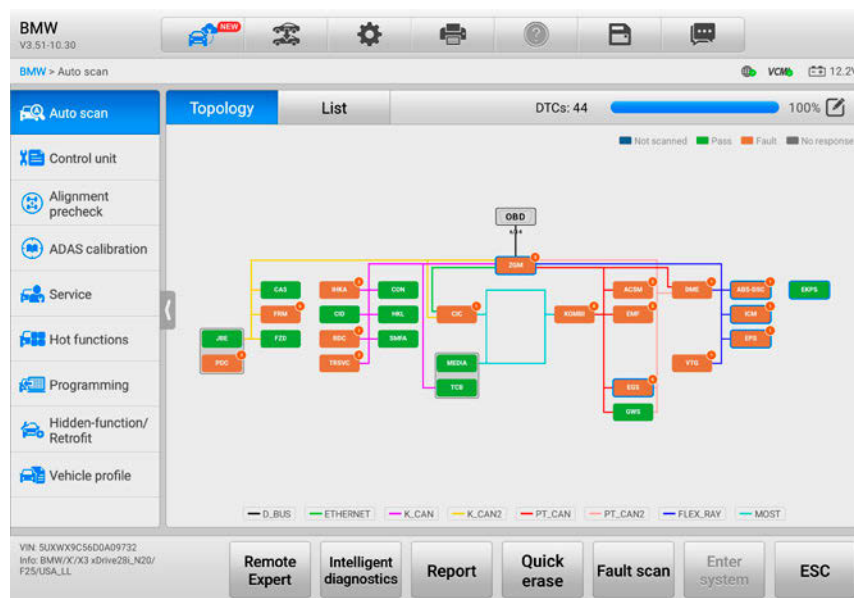

▲ Figure 1- An Autel Ultra connected to a 2013 BMW X5 vehicle. It shows the network topology of the vehicle and which modules are reporting codes.

follow-up with our on-vehicle diagnostics.

If we are unable to duplicate the customer's concern, we talk with them about not being able to duplicate the issue, and that will affect the accuracy of the diagnosis. This could very well impact the amount of time the diagnosis takes as well as create an additional expense. I always suggest bringing the vehicle back when they can consistently duplicate the issue and show us how to do it. This cuts down the diagnostic time dramatically and will save the customer money.

To reassure the customer, I will agree there is a issue between the bumpers, but if it isn't acting up, there is no efficient way to locate the point of origin. Some years back, a customer didn't believe me when I

couldn't duplicate their issue and was getting angry with me for it. To defuse the situation, I politely asked them to go for a test drive with me.

They were very apologetic after the test drive. They explained to me the car had been vibrating all the time for the past several days, and even on the way to the shop. Once they went for a test drive and realized it had simply stopped, they understood.

TRIANGULATING THE LOCATION

When looking at the network topology map, you want to look to see which modules are on the different network buses. You are also going to look at the trouble codes to see which modules are reporting, and which modules are not reporting. ➔

**AAPEX
ATTENDEES**

**Find us at
Bay 2, R8133**



RCCS3 ADAS HAS ARRIVED

THE FUTURE OF ADAS IS COMING TO AAPEX.

Calibrations, simplified. **TEXA**

Cutting edge technology saves you space with digital targets.

The TEXA Radar Camera Calibration System 3 (RCCS3) uses a mini on-board PC and a 75" 4k monitor, both synchronized with the diagnostic software to digitally display automatically positioned targets based on vehicle selection. Simple and easy to use, the RCCS3 clears considerable workspace in the shop and simplifies operator workflow. The RCCS3 has several features that allow the operator to perform micro-adjustments and align the unit easily and with precision.



4K 75" SCREEN

The RCCS3 ADAS unit offers an optimal display, meeting the 1:1 proportion ratio in line with the specifications of the manufacturer. Say goodbye to those panels taking up your valuable space.



BUILT TO LAST

RCCS 3 is made up by a very robust main support, which height can be adjusted thanks to its electrical operation. Using practical knobs, it can be easily tilted to the side and forward.



MINI ONBOARD PC

An actual Mini PC built into the unit, synchronizing the IDC5 software and TEXA unit. Images of the panels are transmitted and positioned automatically.



Circle 62 on card or click "PTEN e-inquiry" on VehicleServicePros.com

**SCAN HERE FOR MORE INFORMATION AND
REQUEST A DEMO.**

TEXA USA inc.
409 Joyce Kilmer Ave,
New Brunswick, NJ, 08901
www.texausa.com
northamerica@texa.com
+1 855.200.8392

TEXA

TOOLS USED:

- AUTEL ULTRA SCAN TOOL
- IDENTIFIX
- SNAP-ON ZEUS OSCILLOSCOPE
- MITCHELL 1
- SNAP-ON VANTAGE LEGEND COMPONENT TEST METER
- BLUE POINT EECTBOB BREAK-OUT BOX
- FLUKE 233 DIGITAL MULTIMETER
- POWER PROBE 3 CIRCUIT TESTER

This will help you to determine if you have a single module down, or if the entire bus is down.

Part of a diagnosis may be disconnecting modules from the network bus to determine if that module failed. We always start with the most easily accessed modules or bus bars. Some of the diagnostic may also include checking the network at the module connector with an oscilloscope such as Snap-on's Zeus scanner (Figure 3).

We are looking to see if signal activity is present and at the appropriate voltage levels. We will refer to vehicle service information, such as Mitchell 1 for specific network voltage levels, and in some case instances, "known good" waveforms.

Keep in mind that when we are looking at network communication, the speed at which communication occurs will not be able to be seen by a voltmeter. It simply doesn't have a fast enough sample rate. Also, remember that most voltmeters are average responding, which could be quite confusing if you don't consider that. On slower networks, you can use Snap-on's Vantage Legend (a 2-channel power graphing meter) (see Figure 4).

If you don't have access to an oscilloscope, consider purchasing a logic probe. Be careful to get one fast enough for the network that you are working on. Knowing the network speed and the speed your tool is capable of are key to a successful diagnosis. We are on the verge of going to

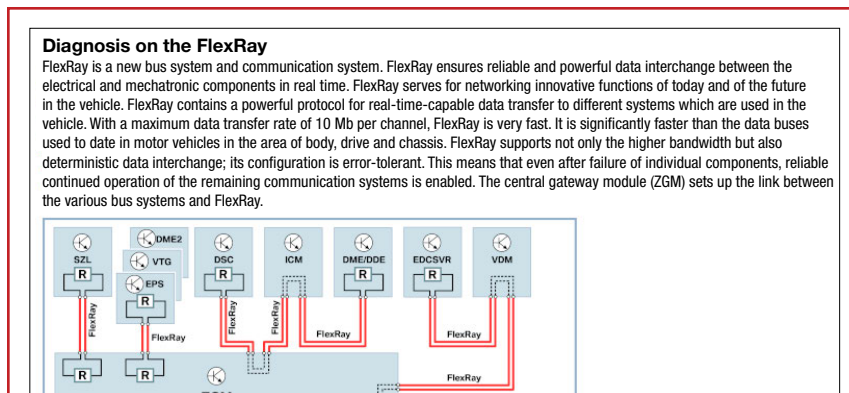

▲ Figure 2- Identifix screen showing the factory wiring diagram for the Flex Ray network from a 2013 BMW X5.

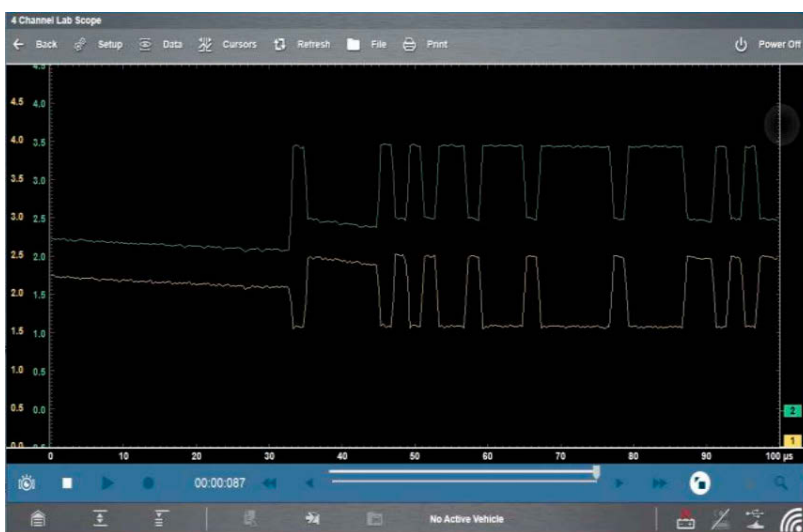

▲ Figure 3- A screenshot from a Snap-on Zeus scanner/oscilloscope showing CAN bus network waveforms.

10Gps automotive networks with 5G and "connected-cars" just around the corner.

SEEING IS BELIEVING

One of my favorite new tools for working on networks is the Blue-Point EECTBOB (an intelligent OBD-II breakout box) (Figure 5). The tool is a great provider of quick network status. It will show the system voltages and grounds. You can change the pin that you are looking at to see voltage levels, and it also has LEDs for each of the pins to visibly indicate activity. Most of your vehicles today will have multiple network protocols in use at any given time. Because of this, you must have the network topology map to determine which network the problem

exists in, and how to go about diagnosing the problem.

In the example of a 2013 BMW X5, referencing Figure 1, we used the Autel Ultra to scan the vehicle. We were able to determine we had a problem with the flex ray network. We have trouble codes for no communication with electronic power steering, and we also have a trouble code for being unable to communicate with the PCM (DME). There were several codes in other modules for the flex ray network being down as well, so that raises a few questions:

1. Why did we get the trouble code from the PCM for being unable to communicate? The reason for this is that the PCM also communicates on PT CAN and PT CAN 2 buses.

2. Why couldn't we communicate with electric power steering?

Because the flex ray network is down, and that is the only network that it communicates on.

ISOLATING THE FAULT

Our next step was to begin disconnecting easily accessed modules on the flex ray network and rescanning the network for communication. We started with the ABS module and also checked our network communication and voltages with our Snap-on Zeus oscilloscope. The voltages for the network at the ABS connector indicated there was no communication activity present, so onto the next module.

We then went for the electric power steering module mounted on the power steering rack. Bingo! We found battery voltage on one of the network lines, and we could see the other network line attempting to com-

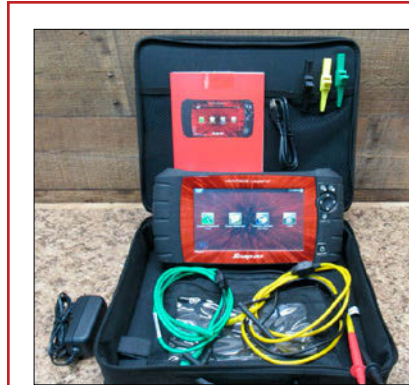

▲ Figure 4- Snap-on's Vantage Legend two-channel graphing meter.



▲ Figure 5- A Blue-Point intelligent OBD-II breakout box.

municate. Further inspection revealed the network line had rubbed through and was shorting to a battery voltage feed.

We repaired the wires, rescanned the network, and we now had communication restored. By looking at the topology map, we can see all the other networks originated from the ZGM (which is our network

gateway). You can think of a network gateway as the translator, so that all the different networks languages can share data.

Because of this, the breakout box would only allow us to see between the OBD-II connector and the ZGM module. All other tests would have to be done intrusively with an oscilloscope.

ASSOCIATED

The Battery Chargers Professional Technicians TRUST



IBC6008MSK

- Safely charges ALL 12V EFB (Start-Stop), AGM, Lithium, Gel and SLA battery types
- Customize battery charging profiles with adjustable voltage and adjustable amperage by type
- Built-in reflash power supply and memory saver port with 12 ft. OBDII cord
- Patented Intellamatic® smart charger analyzer technology with battery rejuvenation
- Partial Charge mode for busy shops
- Energy efficient and OE manufacturer approved
- Legendary power and generational quality
- "Safe in any weather" operation

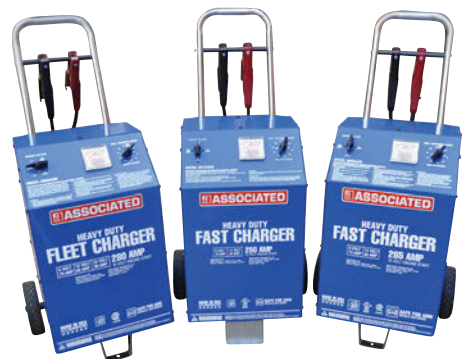

6006AGM/6009AGM/6012AGM

- Upgraded "tried and true" heavy duty chargers with setting for AGM batteries
- Improved energy efficiency
- Legendary power and quality

AMERICAN MADE, FAMILY OWNED | #IWANTTHEBLUEONE

5043 Farlin Ave., St. Louis, MO 63115, 800-949-1472, www.associatedequip.com
Visit us at AAPEX Booth 4826

Circle 63 on card or click "PTEN e-inquiry" on VehicleServicePros.com



THE SECOND CHALLENGER

Next was a 2009 Chevrolet Traverse that came to us as a "no-start." When we first scanned the vehicle, we were missing the ECM, TCM, and ABS modules. By looking at the initial network topology (using Mitchell 1 service information), the ECM was at the end of the line followed by the TCM, and then the ABS module, just before it entered the passenger compartment (Figure 6).

I scanned the vehicle with manufacturer-specific software to find out these modules were missing from the bus. My next step was to check the resistance of the network for the terminating resistors. I used my Fluke 233 digital volt ohm meter, with a magnetic detachable screen (Figure 7).

When I tested the network at the OBD port, it only measured 120 ohms. A properly functioning network should measure 60 ohms. This led me to believe I was missing one end of the network.

I then scanned the vehicle with global OBD-II and received information from the ECM. The information reported under global OBD-II, but in reality, it was coming from the fuel pump control module.

My next step was the ABS module since that was the first one in line not reporting. At the ABS module, I found a broken retaining clip on the electrical connector. The connector was simply un-mated and was not making any electrical connection.

YMMS: 2009 Chevrolet Traverse LS
 Engine: 3.6L Eng
 VIN: 1GNER13D59S157824

Aug 29, 2022
 License:
 Odometer:

COMPUTER DATA LINES

Fig 1: Computer Data Lines Circuit (1 of 2)

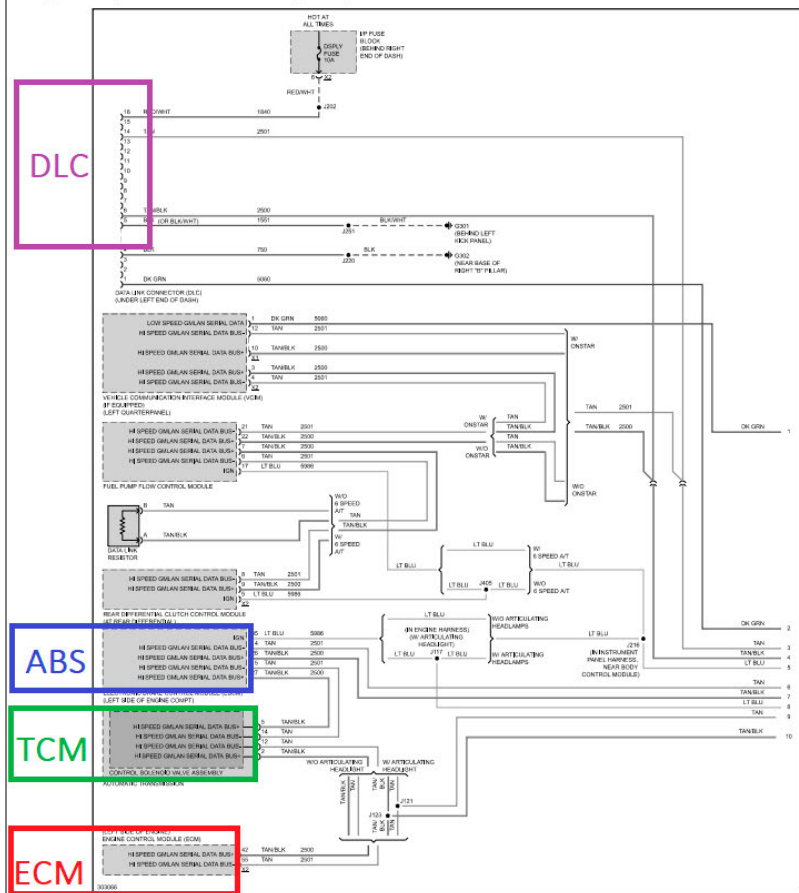

▲ Figure 6- This is from the Mitchell 1 ProDemand to show how they display network topology. This is one of 3 sheets.

»» RELATED TOOLS



S & G Tool Aid
 Circuit Tester with Digital Display,
 No. 28350
 Circle 64 on card or click "PTEN e-inquiry" on VehicleServicePros.com

TOPDON
 Phoenix Max Diagnostic
 Scan Tool
 Circle 65 on card or click "PTEN e-inquiry" on VehicleServicePros.com



Launch Tech
 O2-1 Scopebox
 Circle 67 on card or click "PTEN e-inquiry" on VehicleServicePros.com

Curien
 N2 Neuron Dual Channel
 Bluetooth Graphing Multimeter
 Circle 66 on card or click "PTEN e-inquiry" on VehicleServicePros.com



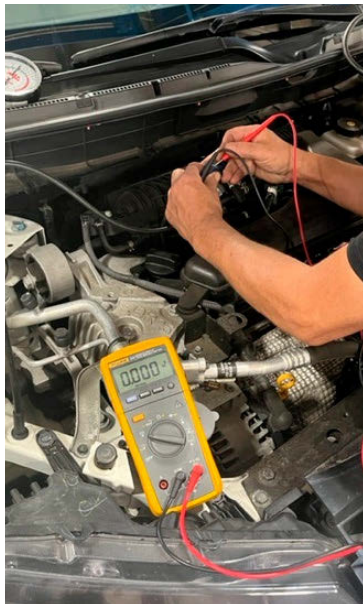

▲ **Figure 7-** A Fluke 223 detachable display digital volt-ohm meter.



▲ **Figure 8-** A PowerProbe III.

I checked for proper available voltage and grounds with my Power Probe 3, but only the voltage and grounds feeds (**Figure 8**). Never use a Power Probe on a computer data line. It is too easy to make a simple mistake and damage a module permanently. I find it useful when testing ADAS blind spot sensor powers and grounds because of the extended cord reach.

When it comes time to troubleshooting network issues, it boils down to a repeatable diagnostic process; to both locate and repair these faults quickly and efficiently. On some of the more difficult network issues, we have used a team approach. One person will do the physical work on the vehicle while the other person will be determining the diagnostic tests. We find this makes for a faster diagnosis. Keep in

mind you have to bill accordingly to cover the two technicians.

Without the proper service information or tooling, it will be impossible to fix these vehicles profitably. Take the time now for training and give yourself enough time to look at the different systems with your diagnostic tools, so you know what a "known" good and bad each look like. ❌



ROSS COLKET is the owner of Colket Automotive Technical Services in Lansdale, Pennsylvania. He is an ASE Certified Master Technician with

over 30 years of experience as both a technician and educator. As a former CTI instructor, he believes in the importance of training and giving back to the industry. Ross fully supports and believes in Motor Age's mission to "advance the automotive professional."

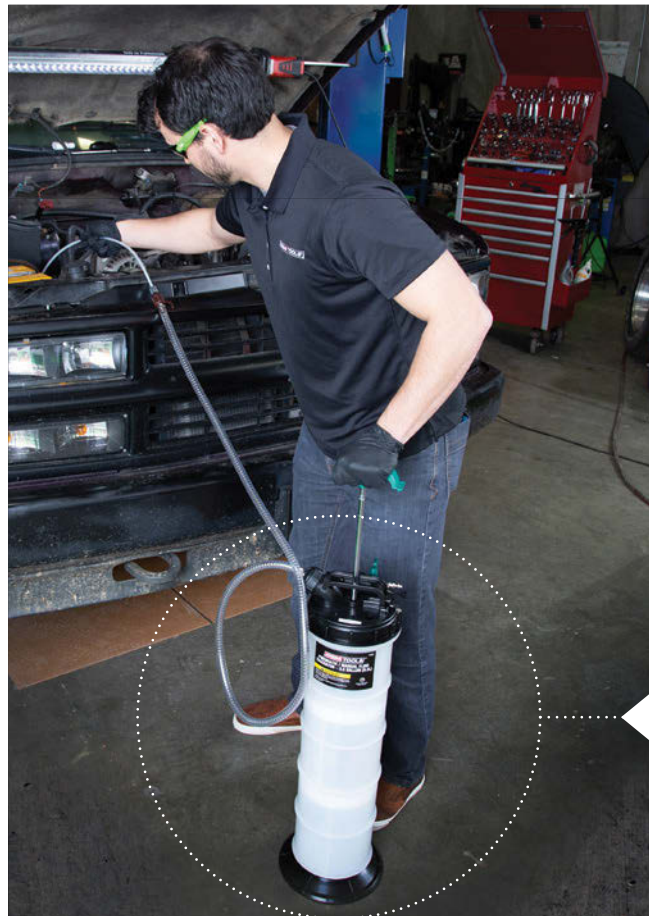

OEM TOOLS
FAST IN CLASS

FAST. EASY. CLEAN.

PNEUMATIC AND MANUAL FLUID EXTRACTORS

- Removes Many Fluid Types: Engine Oil, Transmission Fluid, Coolant, Power Steering Fluid, Water
- Automatic Shut-Off Valve Prevents Overflow
- One Piece Leak Proof Reservoir
- 5 Ft. Main Suction Flexible Hose and 2 Dipstick Adaptors



#24389
Manual Function
1.4 Gallon
5.3 Liter



#24936
Manual Function
2.1 Gallon
8 Liter



#24938
Pneumatic & Manual Function
2.5 Gallon
9.5 Liter



#24937
Pneumatic & Manual Function
1.5 Gallon
6 Liter

Scan QR code or search bit.ly/COVEREDOct22 to get deals on all OEMTOOL Fluid Extractors



WHEN FAILURE IS NOT AN OPTION



Duralast[®] PROVING GROUNDS

TOUGH ENOUGH FOR THE EXTREME, BUT MADE FOR EVERYDAY DRIVING. DURALAST PARTS ARE ENGINEERED TO MEET OR EXCEED OE PERFORMANCE, AND THEY'RE TESTED TO HOLD UP IN EVEN THE MOST EXTREME CONDITIONS ON OUR PROVING GROUNDS. BECAUSE YOUR REPUTATION DEMANDS IT, AND YOUR CUSTOMERS DEPEND ON IT.

EXPLORE WHY AT [DURALASTPARTS.COM/PROVINGGROUNDS](https://duralastparts.com/provinggrounds)



Follow MotorTrend on Facebook and Instagram
for Stories from SEMA presented by DURALAST



MORE TECHNICIANS CHOOSE DURALAST PARTS*



* Source: Proprietary Consumer Study of
Automotive Aftermarket Parts Conducted by The
NPD Group, 2019

Circle 69 on card or click "PTEN e-inquiry" on VehicleServicePros.com

Curien N2 Neuron and A1 Low Current Amp Clamp

Reviewed by Pete Rudloff, owner of Pete's Garage Inc. in Newark, Del.



PRODUCT DESCRIPTION

The **Curien A1 Low Current Amp Clamp** features a 1/2" jaw to fit most cables, a rubberized body for ease of stability and grip, and 4mm banana plugs for use with Curien's N2 or other meters. With a 10mA to 80A coverage, the low current amp clamp is ideal for parasitic draw and small to medium range component testing. Additionally, it has a safety rating of CAT II 600V, a 9V battery that automatically shuts off to ensure long life, and comes in a hard zippered case.

Circle 70 on card or click "PTEN e-inquiry" on VehicleServicePros.com

The **N2 Neuron Dual Channel Bluetooth Graphing Multimeter** by Curien is designed to enable freedom of movement while testing electrical, temperature, and other systems. N2 is integrated with data interpretation and intelligence software, enhancing the diagnosis of most electrical circuit problems and providing training, community, and help forums to increase the user's capabilities. The composite, rubberized body is resilient and built for shop life, while its compact size allows for access to tight areas and road tests. In addition, the onboard 24-bit processor allows for two streams of measurements to be simultaneously processed and transmitted at high resolutions. The N2 comes with standard 4mm banana jacks, over-the-air updatable firmware, and a two-year warranty, as well as accepts BNC adapters.

Circle 71 on card or click "PTEN e-inquiry" on VehicleServicePros.com

Q: How did the tool function as far as saving you time?

A: It saved time by not having to route wires from under the hood to the driver compartment to road test while monitoring a circuit. It also increased speed at which screen captures can be shared.

Q: What kind of setup was involved before using the product?

A: Minimal set up - just install the supplied batteries, download an app after scanning a QR code, and all was up and running. I set this up on a Google Pixel 5 with Android version 12.

Q: How was its packaging? Did it come with any accessories?

A: From the sleek-looking retail packaging to the semi-hard clam shell case that is supplied for normal storage, it screams quality storage solutions. The accessory leads feel very high-quality.

Q: Was there a manual included?

A: A quick-start guide was included, and there was a link to access the full manual, plus demonstration videos and a user-based forum. A nice, magazine grade booklet was also included.

Q: What features did you like?

A: This is a feature-packed tool. It's hard to pick just one or two good features. The ability to have the meter hooked up under the hood and a display in the passenger compartment while driving is convenient. Additionally, the amps present feature when checking fuses is slick and a huge

time saver. I've not seen that built into a tool before.

Q: How easy was it to use?

A: The tool side of this is super simple. Anyone with meter experience won't have any trouble installing the leads. The app is easy to use at a basic level without any training. The meter packs many features, so spending some time watching the related training videos will certainly expand what you can do with it.

Q: Is there any way you could think to improve or add to this tool?

A: Making the amp clamp Bluetooth would be helpful. Also, extending the time it takes to disconnect would be good. Every time I left the app and came back to it, the meter and phone had disconnected. It'd also be nice to include an SD card, so the logging feature is automatically enabled.

Q: On a scale of 1 to 10, how would you rate this tool overall? Why?

A: A solid 9, great bang for the buck. ⓧ



PETE RUDLOFF is a nationally awarded technician, national automotive instructor/consultant, technical writer, software developer, automotive trade advocate, and owner of Pete's Garage Inc. in Newark, Del. Rudloff has a national reputation as friend to the general auto repair shop and is known for fixing difficult to fix cars and facing challenging trade issues head-on. In 2016, Rudloff created FlexCheck Auto DVI in order to help independent auto repair shops nationwide increase their revenue.

This product was given to the reviewer free of charge from the manufacturer.



FOR MORE INFORMATION ON THESE PRODUCTS,
CLICK ON "PTEN E-INQUIRY"
at VehicleServicePros.com
OR CIRCLE THE NUMBER ON THE CARD.

KNIPEX CutiX Universal Snap Knife

Reviewed by John Baumgardt III, owner of Baumgardt's Auto Repair in Fillmore, Ind.



Q: How did the tool/equipment function as far as saving you time?

A: The blades that came in the knife seemed to be stronger and sharper than other blades of the same type, allowing them to last longer and require stopping less to change.

Q: What features did you like?

A: The magnesium casing of the knife was easy to grip with wet, dry, or oily hands. The tether hole is nice for when you're working up high and want to make sure

you don't drop it. Blade changes are easy, and it comes with a place to keep a couple of extra blades onboard – this is a great feature. I was impressed with the quality of blades that came with it. The blade support is an awesome feature. It serves three purposes in my mind.

- Reduces flex in the blade making it easier to make straighter cuts in materials like styrofoam.
- Helps prevent unwanted blade breakage when using the blade at an extended length.
- Makes it possible to place added pressure on the top of the blade for when you're trying to squeeze that last cut out of a section of the blade before having to snap it off.

Q: How has using this tool impacted your shop's profitability?

A: As usual, time is money, and anything that saves time creates the opportunity to be able to move on to the next job.

Q: Was there a manual included?

A: No manual included, just the features printed on the paper insert that surrounds the knife.

Q: How was its packaging? Did it come with any accessories?

A: It came packaged in the typical clear form-fitted plastic that oddly enough makes you wish you had the knife to cut

it open. The knife comes with two extra blades that are stored in the removable rear portion of the knife.

Q: Is there any way you could think to improve or add to this tool?

A: It's a small thing, but it would be nice if there was a way to snap the dull portion of the blade without having to have another tool. I usually have something with me anyway, though.

Q: What types of jobs did you use this tool for?

A: I used it to break down a ton of boxes. It slices through cardboard like a ninja sword. I used it to trim back some damaged portions of plastic inner fenders. I cut a 3" wide industrial rubber belt that was 3/4" thick into pieces to make small engine mounts for a project I'm working on.

I used it to cut up some old carpet, sliced through a bunch of scrap 2" styrofoam insulation, and cut through a lot of twine, paracord, nylon rope, and several other types of material, including leather. The knife worked great and cut everything I threw at it. I even used it to cut steak – raw and cooked. Cut like a dream. ✕



JOHN BAUMGARDT III is the owner/operator of Baumgardt's Auto Repair in Fillmore, Indiana. He has been a professional auto tech for about 20 years. He attended the two-year Auto Mechanics program at Lancaster Vocational High School. Previously, Baumgardt worked at AAMCO Transmissions and earned about a dozen AAMCO certificates. He believes it's important to provide an honest, quality service that people can depend on.

This product was given to the reviewer free of charge from the manufacturer.

PRODUCT DESCRIPTION

The **KNIPEX Tools CutiX Universal Snap Knife**, No. 90 10 165 BKA, features an extendable stabilization bar that keeps the blade from bending for quicker cutting. The stabilization bar can be engaged or retracted based on application, and allows the user to apply more pressure directly on the blade. The CutiX also features a hardened steel pin to secure the blade. Constructed with a lightweight magnesium housing, the knife has non-slip gripping surfaces and two separate sliders - one for the blade and one for the stabilization bar. Suitable for all 18mm snap-off blades, the CutiX comes with two blades that have seven cutting points, stored in the handle.

Circle 72 on card or click "PTEN e-inquiry" on VehicleServicePros.com

Innova 5610 CarScan Pro

Reviewed by Rich Falco, technician/instructor for Diag on Demand and Carquest Technical Institute in Palmetto, Fla.

Q: How did the tool function as far as saving you time?

A: I used this scan tool for several weeks as my first “go-to” tool for pulling and clearing codes, performing some service resets, looking at live data, and completing monitors on several vehicles. Since it is a handheld unit with no VCI, there was no waiting for the scan tool to connect. It was very fast to identify the vehicle and perform those basic functions.

Q: What kind of setup was involved before using the product?

A: There was no setup required with the tool, however, there is an app that can be connected via Bluetooth, so users can store reports and access a verified fix database.

PRODUCT DESCRIPTION

The **Innova 5610 CarScan Pro** is a scan tool designed to help technicians find and fix problems more efficiently. More than a stand-alone tool, it includes access to Innova’s RepairSolutions2 knowledge base of over 60 million verified fixes. With 5610, users receive vehicle-specific inspection reports with fixes, guided diagnostics, and troubleshooting information. Advanced features include oil life, brake pad life, battery voltage, TPMS status, and live data. Fixes for body and chassis codes and full network scan results are available for supported vehicles. Factory and NHTSA recalls, TSBs, service maintenance, and predictive diagnostics help shops alert customers of potential issues.

Circle 73 on card or click “PTEN e-inquiry” on VehicleServicePros.com

Q: How easy was it to use?

A: The tool is very easy and intuitive to use.

Q: How was its packaging? Did it come with any accessories?

A: A small carrying case and a USB cable were included for future updates.

Q: Was there a manual included? If so, did you use the manual, and was the manual easy to understand?

A: There was a small manual included that included basic functions and instructions for downloading the app and connecting the tool to Bluetooth on your phone.

Q: What features did you like?

A: The speed at which it connected to my Mercedes Sprinter and pulled global and manufacturer-specific codes was impressive. I also cleared codes from several other models such as Honda, Toyota, and VW.

Q: What types of jobs/repairs did you use this tool for?

A: Checking codes on a 2014 Sprinter and clearing codes after the repair. Quick pre-scan for codes on a 2005 Honda Element and viewing live data in the PCM for drivability issues. I was able to quickly identify a high MAP reading, indicating a need for a valve adjustment and confirm readings were normal after the valve adjustment. Scanned several other vehicles for codes.

Q: How does this tool compare to other tools you’ve used like it?

A: As a professional technician, I was not expecting much of this scan tool. It operates and feels very much like a DIY-style



tool. I would normally own a much more capable tool, so I did not have to depend on the shop-supplied scan tool. However, I could see this being a good scan tool for a brand-new technician who wanted to be able to check and clear codes and perform basic resets required after a battery replacement or maintenance procedure. A general service technician would be able to afford and use this tool efficiently until he had the experience and need for a higher-level tool.

Q: Any questions or concerns about the tool?

A: My first impression was that this scan tool was too flimsy to survive a working technician who is admittedly rough on their equipment. All of my tools travel in my van. I was intentionally rough on this tool. It has handled it all well and is still going strong. ❌



RICHARD FALCO is an ASE Master Certified technician with over 30 years of experience in the auto repair industry. His technical experience includes domestic, Asian, and European vehicles at the dealer level and as a successful shop owner. He has instructed technicians and college students in all aspects of auto repair for Carquest Technical Institute and is a member of Trained By Techs.

This product was given to the reviewer free of charge from the manufacturer.



FOR MORE INFORMATION ON THESE PRODUCTS,
CLICK ON "PTEN E-INQUIRY"
at VehicleServicePros.com
OR CIRCLE THE NUMBER ON THE CARD.

GEARWRENCH 10-pc Bolt Biter Screw Extractor Set, No. 84786

Reviewed by John Baumgardt III, owner/operator of Baumgardt's Auto Repair in Fillmore, Ind.

Q: How did the tool function as far as saving you time?

A: The drill bits are sharp and cut well. The extractors bite and hold well.

Q: How has using this tool impacted your shop's profitability?

A: The drill bits and the extractors being together in a kit saves time, and that adds up.

Q: How was its packaging? Did it come with any accessories?

A: It came in a thick, clear plastic package that holds the storage case wide open, so you can see exactly what you're getting. The storage case is made of what seems to be sturdy plastic similar to an average



size drill/driver bit set. It's not too bulky but not too small that it'll easily be lost. It's also clear and orange, so that will help you keep tabs on it as well.

Q: How easy was it to use?

A: It's very easy to use. Choose the drill bit and extractor from the kit that will leave you a little meat left for the extractor to bite into. Drill your hole, tap the extractor into the hole and turn.

Q: What features did you like?

A: I really like how the extractors will bite for both directions. When I have to use one of these tools, I never plan on reusing the fastener. A lot of extractors only bite turning left, which makes it about impossible to turn back and forth to work the broken fastener loose. These will also work on broken bolts with left hand threads.

Q: Was there a manual included? If so, did you use the manual and was the manual easy to understand?

A: Yes, behind the drill bits was an easy-to-read and understand set of instructions. Illustrations were also included.

Q: Is there any way you could think to improve or add to this tool?

A: I think that the quality of everything was top notch. That being said, the packaging,

the information I've seen online, and even the instructions inside the case all said it had left-handed drill bits, but I had right handed drill bits in mine. Personally, I feel that left-handed drill bits are somewhat of an extractor themselves, adding value to the kit.

Q: What types of jobs/repairs did you use this tool for?

A: I had a big brake job where I was replacing all the brake lines on a truck with 350K on the clock. Needless to say, there were a few hang ups when it came to removing bleeder screws and a few other bolts. The drill bits chewed into the bolts and bleeders like they were butter. The extractors bit into the metal and held well. I also used them to remove a couple broken exhaust manifold bolts from a GM 4.2L Envoy, and they worked great.

Q: On a scale of 1 to 10, how would you rate this tool overall? Why?

A: Eight. The overall feel and quality are what I would expect from GEARWRENCH, but I feel that a one year warranty on the extractors leave much to be desired. I have other extractors with a lifetime warranty. The hex heads on the extractors are a great idea and will make turning them so much easier. ❌



JOHN BAUMGARDT III is the owner/operator of Baumgardt's Auto Repair in Fillmore, Indiana. He has been a professional auto tech for about 20 years. He attended the two-year Auto

Mechanics program at Lancaster Vocational High School. Previously, Baumgardt worked at AAMCO Transmissions and earned about a dozen AAMCO certificates. He believes it's important to provide an honest, quality service that people can depend on.

This product was given to the reviewer free of charge from the manufacturer.

PRODUCT DESCRIPTION

The **GEARWRENCH Bolt Biter Screw Extractors** are designed to grip stripped, frozen, and damaged screws. The extractors use patented tapered sides to sit easily and safely into damaged screws, providing powerful and consistent extraction. The bidirectional design makes it easy to remove fasteners from the extractor after use and allows for fasteners to be retightened. The extractors are made from high-strength steel, have a black oxide coating for corrosion resistance, and have high-visibility laser markings for easy size identification. They are compatible with fastener sizes $\leq 1/4"$ to $5/8"$ and M5 to M16. Available in a 4-pc set, No. 84787, or a 10-pc set, No. 84786 (includes five sizes of extraction drill bits for removal needs).

Circle 74 on card or click "PTEN e-inquiry" on VehicleServicePros.com

PTEN

PEOPLE'S 2022 CHOICE

Now for the eighth year, we asked our readers to weigh in on the *PTEN* Innovation Awards. Named the 2022 *PTEN* People's Choice, the following pages feature the top 24 products selected by our readers, per product category, that were originally nominated for the 2022 *PTEN* Innovation Awards.

Hunter Engineering

Quick Check Commercial Autonomous Inspection System

The **Hunter Engineering Quick Check Commercial Autonomous Inspection System** is an unmanned alignment and tire tread inspection system designed to measure camber, total toe, and tandem axle scrub for commercial vehicles.

The system provides instant and automatic touchless alignment and tread depth results on all axles for all trucks, using 40 optical and laser sensors to provide easily comprehensible 3D tread depth models that can be displayed on a large video monitor. Since the unmanned system requires only driving the vehicle between the towers, trucks can be cycled through continuously without operator time or labor, providing actionable data affecting fuel economy and tire life. Quick Check Commercial supports multi-trailer configurations, dual axles and super-single tires, as well as full size and medium duty trucks.

CATEGORY: Inspection Tools & Lab Scopes

Circle 75 on card or click "PTEN e-inquiry" on VehicleServicePros.com



Mechanic's Time Savers

Switch Cart

The **Mechanic's Time Savers Switch Cart** can be opened by sliding or flipping open, allowing users to utilize the top as a work surface while still being able to access their tools by sliding open. The cart measures 36" in width by 26" in depth by 45" in height. The top lid has 175-lb slides, the three drawers have 125-lb slides, and the lift-latch drawer pulls. The cart has 6" casters, heavy duty construction, and a power strip. It's available in three trim colors: black, red, and yellow.

CATEGORY: Tool Storage

Circle 76 on card or click "PTEN e-inquiry" on VehicleServicePros.com



Snap-on

EEAC334B Polartek
Dual AC Machine

The **Snap-on Polartek Dual AC Machine**, No. EEAC334B, is able to measure both R-134a and R-1234yf refrigerants with a simple push of a button. The unit handles both refrigerants with dedicated 30-lb tanks, removing the risk of cross-contamination and making it easy to get repeatable and accurate results without doubling work or cost. The machine's built-in Wi-Fi



capabilities and graphic touchscreen enable technicians to efficiently maneuver through selections and a large status light helps monitor progress from afar while completing other tasks.

CATEGORY: Air Conditioning Service

Circle 77 on card or click "PTEN e-inquiry" on VehicleServicePros.com



Autel

MaxiSYS MS909CV Commercial Vehicle Diagnostics Tablet
The Autel MaxiSYS MS909CV Commercial Vehicle Diagnostics Tablet is compatible with more than 80 models of light, medium, and heavy duty vehicles. With a 9.7" wireless, Android-based touchscreen, it performs extensive diagnostics, including the ability to read/erase codes, view and graph live data, and perform active tests. The tablet includes a Bluetooth-enabled VCI/J2534 Pass-Thru programmer, MaxiBAS B200 battery starting/charging system test device, and a multimeter. The tablet also includes ADAS calibration software for Class 3 to 5 vehicles and Class 6 to 8 vehicles with dynamically calibrated systems. The MS909CV includes one year of free software updates.

CATEGORY: Heavy Duty Scan Tools

Circle 78 on card or click "PTEN e-inquiry" on VehicleServicePros.com



Ingersoll Rand

1" Cordless Impact Wrench, No. W9691

The **Ingersoll Rand 1" Cordless Impact Wrench**, No. W9691, is designed to increase safety and productivity with cordless mobility eliminating hoses and tripping hazards. It features a brushless motor, 3,000 lbs of torque and an IP56 rating. The IQV20 batteries perform up to 250 bolt removals and installations in a single charge. An ergonomic D-handle with a 360-degree auxiliary rotates fully around the tool as the job demands. It also features a 6" anvil to provide additional flexibility. Full-power reverse, and three additional power modes allow for greater control, preventing over-tightening and stripping.

CATEGORY: Power Tools

Circle 80 on card or click "PTEN e-inquiry" on VehicleServicePros.com



Carlyle Tools by NAPA

Dual Charging Wireless Lighting System

The **Carlyle Tools Dual Charging Wireless Lighting System**, No. MWCP2, is designed to charge up to two wireless charging-capable accessories at once. The charging pad is equipped with an advanced QC3.0 Power+ charging system and 5V2A max output 10W charger and is intended for use with optional QC 3.0 max output 18W smart charger for faster charging. It includes a retractable phone holder for use with most wireless charging compatible phones. Strong magnets are also included to enable mounting to most clean, flat, metal surfaces, and screw holes have been incorporated if wall mounting is preferred.

CATEGORY: Lighting

Circle 79 on card or click "PTEN e-inquiry" on VehicleServicePros.com



ESAB

EMP 210 MIG/Stick/TIG Welder

The **ESAB EMP 210 MIG/Stick/TIG Welder** is lightweight and offers dual-voltage input power flexibility, offering ideal portability for around the shop. The multi-process MIG/flux cored/stick/lift TIG welding system has a 10-200A output, a stable Lift TIG arc at low amperage for finesse welds, and the power to run Stick electrodes up to 5/32", including 7018. Additionally, it features a large easy-to-read LED display with digital controls for fast and accurate operation and can run off a generator with a 10 kVA output.

CATEGORY: Welding

Circle 81 on card or click "PTEN e-inquiry" on VehicleServicePros.com



Autel
 MaxiSYS MS906PRO
 and MaxiBAS BT506

The **Autel MaxiSYS MS906PRO** and **MaxiBAS BT506**

together offer diagnostics and battery analysis functionality. The MS906PRO is an advanced tablet that

performs extensive vehicle diagnostics including an all system AutoSCAN with ADAS identification, read/erase codes, view freeze frame, and live data. Bidirectional controls including active testing, coding, and adaptations are also included. The BT506 is a battery and electrical system analysis tool that uses adaptive conductance to produce a more accurate examination of a battery's cold cranking ability and reserve capacity. Users can view the battery's and electrical system's health status using the free mobile app.

CATEGORY: Automotive Scan Tools

Circle 82 on card or click "PTEN e-inquiry" on VehicleServicePros.com



Snap-on

12V Engine Starter Plus
 with AGM, No. EEJP700

The **Snap-on 12V Engine Starter Plus with AGM, No. EEJP700**, is a rotary

switch engine starter designed to make jobs easier for any automotive technician by connecting and starting 12V vehicles with no sequencing required. For added safety, it can also detect reverse polarity. The case features convenient magnetic holders for clamps that have crank assist of 550A from a high output sealed 33 Ah AGM internal battery. It also features a USB charging port, an easy-to-use interface, field replaceable battery, and long reach 65" high flow 2-gauge welding wire cables.

CATEGORY: Battery Starting & Charging

Circle 84 on card or click "PTEN e-inquiry" on VehicleServicePros.com



Over 50 years of OEM quality at aftermarket prices!



Scan for our catalog



Cat. No. 89360
 5 Pc. Body Punch Set
 • 5 profiles for forming hard to reach areas
 • Polished and hardened surfaces
 • 12" OAL



Cat. No. 18840
 Battery Terminal Crimper
 • 8 - 4/0 AWG
 • Uninsulated terminals
 • 26" OAL



Cat. No. 18700
 Master Terminal Service Kit
 • Crimps Deutsch, Weather Pack, Metri-Pack, and many other open and closed barrel terminals
 • Includes disconnects

www.toolaid.com

Circle 83 on card or click "PTEN e-inquiry" on VehicleServicePros.com



FOR MORE INFORMATION ON THESE PRODUCTS,
 CLICK ON "PTEN E-INQUIRY"
at VehicleServicePros.com
 OR CIRCLE THE NUMBER ON THE CARD.

SEMA

SHOW



WHERE CONNECTIONS ARE BUILT

NOVEMBER 1-4, 2022
LAS VEGAS CONVENTION CENTER

REGISTER TO ATTEND AT
SEMASHOW.COM





FOR MORE INFORMATION ON THESE PRODUCTS,
 CLICK ON "PTEN E-INQUIRY"
 at VehicleServicePros.com
 OR CIRCLE THE NUMBER ON THE CARD.

Hunter Engineering

BL Brake Lathe Tablet

The **Hunter Engineering BL Series Bench Lathe Tablet** enables operators to look up the vehicle and access the specifications immediately. The tablet then calculates the distance between the cutting bits on the lathe and compares it live to the specifications, signaling the operator if the rotor or drum is safe to resurface. With a user-friendly display and multilingual interface, the tablet provides information on the depth of cuts, speeds and settings, as well as data such as bore size, lug nut torque and stud type, onboard training videos, text, and animations. After a certain number of cuts, the BitMinder function reminds the user when it's time to rotate the bits.

CATEGORY: Brake Service

Circle 85 on card or click "PTEN e-inquiry" on VehicleServicePros.com



WELD IT ALL.
EVERY PROCESS. EVERY METAL.

HSM200 PRO

- TIG ANY METAL
- MIG ANY METAL
- STICK ANY METAL
- DUAL VOLTAGE
115V/230V
- 200 AMPS OF POWER



PACKAGE INCLUDES EVERYTHING YOU NEED: MIG torch, TIG torch with foot pedal, electrode holder, ground clamp, MIG wire, TIG torch kit, and dual gauge regulator with hose.

Snap-on

14.4V Mini Right Angle Cordless Drill, No. CDRR2005

The **Snap-on 14.4V Mini Right Angle Cordless Drill, No. CDRR2005**, weighs just 2 lbs and features a small surface head for maximum accuracy when working in tight spaces. Its cushion-grip handle and LED makes it easy to navigate while the onboard battery gauge indicates the need for a charge. The mini right angle accepts 1/4"-28 threaded bits and accessories. Its technology includes low runout for smooth and precise drilling, plus it has improved torque to weight ratio and motor life.



CATEGORY: Specialty Tools

Circle 87 on card or click "PTEN e-inquiry" on VehicleServicePros.com

HSAUTOSHOT.COM



FOLLOW US @HSAUTOSHOT

Circle 86 on card or click "PTEN e-inquiry" on VehicleServicePros.com

PTEN 
PEOPLE'S
2022 CHOICE



Rislone
 Cat Complete Fuel, Exhaust, and Emissions System Cleaner, No. 4720

The **Rislone Cat Complete Fuel, Exhaust and Emissions System Cleaner**, No. 4720, is an easy-to-install, cost-effective chemical solution to help customers pass emissions smog tests, turn off check engine lights, clear OBD codes, improve vehicle performance, and save gas. Simply add to half a tank of gas to clean the

vehicle's entire fuel, exhaust and emissions system. Cat Complete uses a proprietary blend of heavy duty detergents and solvents to remove contaminants, soot, carbon build-up, and oily residue from the fuel injectors, combustion chambers, turbo, catalytic converters, oxygen sensors, and exhaust.

CATEGORY: Chemicals

Circle 88 on card or click "PTEN e-inquiry" on VehicleServicePros.com

Hunter Engineering

HunterNet 2 Multi-Store View

The **HunterNet 2 Multi-Store View** from

Hunter Engineering is designed for undercar service operators with multiple rooftops. It

allows operators to access actionable performance data for all their Hunter-connected equipment from across the entire organization, in one place, from anywhere, at any time. Managers can analyze trends and rank all the stores in their network by individual activities such as alignments or number of tires changed, as well as track equipment ROI in real-time. Shops can also view all Hunter assets by age, and thereby plan for capital investments across the network. Additionally, organizations may also easily compare opportunities from inspections verse actual services performed, such as alignments, tire changes, balances, and brake work.

CATEGORY: Automotive Software

Circle 89 on card or click "PTEN e-inquiry" on VehicleServicePros.com

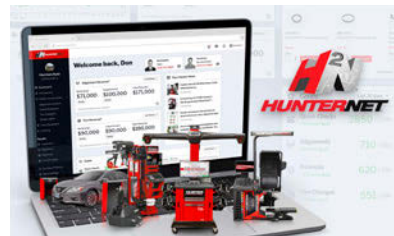

Beta
 Italian design. European quality.

RSC24

Beta Tools USA is a subsidiary of BETA UTENSILI S.P.A. Sovico (MB) - Italy

FROM RACING TO YOUR GARAGE

The **Beta RSC24** is the evolution of perfection.

The iconic C24S toolbox has evolved into the new Beta RSC24, bringing racing character and high performance to your garage. Built in Italy using high-quality materials, it makes for a sturdy cabinet which will deliver a long service life. Below are available accessories:

- PERFORATED TOOL PANEL • COMPUTER BRACKET • FOLDING SHELF
- PAPER ROLL HOLDER • DOCUMENT HOLDER • WOOD WORKTOP
- AVAILABLE IN FIVE COLORS

The new reinforced ABS worktop is designed with 8 holes for screwdrivers and accommodates a wood worktop or matching top box. Accessories are sold separately.

BETATOOLSUSA.COM

+1 717.449.5044



Circle 90 on card or click "PTEN e-inquiry" on VehicleServicePros.com

www.VehicleServicePros.com © OCTOBER 2022 © PROFESSIONAL TOOL & EQUIPMENT NEWS

PTEN 
PEOPLE'S
2022
CHOICE



FOR MORE INFORMATION ON THESE PRODUCTS, CLICK ON "PTEN E-INQUIRY" at VehicleServicePros.com OR CIRCLE THE NUMBER ON THE CARD.



Hunter Engineering

SmartWeight Elite
 Wheel Balancer

The **Hunter Engineering SmartWeight Elite Wheel Balancer** is designed for maximum speed, efficiency and accuracy. The SmartWeight Elite replaces typical dataset arms with diagnostic lasers that automatically scan the entire inner rim, providing precise locations for weight placement, including anywhere along the wheel, rather than only the left or right planes. The balancer's automatic functions include measurement and dimension entry; inside rim runout to identify bent wheels; spoke locations to conceal weights; and CenteringCheck to ensure the wheel is properly centered on the shaft. SmartWeight offers single-weight solutions more often than any other balancer, reducing weight usage and increasing ride quality.

CATEGORY: Tire & Wheel Service

Circle 91 on card or click "PTEN e-inquiry" on VehicleServicePros.com

INNER RACE HUB SAVER 

Fast & Simple!

- Easy, safe removal of inner bearing race
- No need for expensive tools
- Works much faster than other options available

Part #71310

MORE GREAT TOOLS BY... **STECK** INNOVATIVE BODY SHOP TOOLS & EQUIPMENT

See your local tool distributor or visit www.steckmfg.com



Snap-on

40" SubStation Four-Drawer Power Cart, No. KHP415

The **Snap-on 40" SubStation Four-Drawer Power Cart**, No. KHP415, is designed to be a charging substation for any rechargeable tool, providing quick access and easy maneuverability. The lockable top compartment measures 40" width by 20" depth by 11" height. With a slight push, the lid opens revealing its 120V power strip and organization space for 10 power tools and five battery packs. Techs can organize accessories in its 4" Speedrawer with customizable dividers. A 15' cord and custom-mounted cord-wrap provides power access. An 8" bottom drawer holds large power tools and the 6" vibration absorbing casters stabilize the cart.

CATEGORY: Tool Organization

Circle 93 on card or click "PTEN e-inquiry" on VehicleServicePros.com

Circle 92 on card or click "PTEN e-inquiry" on VehicleServicePros.com

Snap-on

SODC1 Soldering Clamp

The **Snap-on Soldering Clamp**, No. SODC1, features a small design, allowing it to fit into tight spaces so technicians can use both hands to solder without the worry of misaligned and shaky wires. The lightweight aluminum tool won't tug on wires and two spring-loaded clamps offer a wide range wire capacity from 22 to 8 gauge, says the company. The convenient, nearby thumbwheel offers quick loading, unloading, and adjustments while precisely bringing wire ends together.

CATEGORY: Tool Accessories

Circle 94 on card or click "PTEN e-inquiry" on VehicleServicePros.com



KNIPEX

TwinGrip Pliers

The **KNIPEX Tools TwinGrip Pliers**, No. 82 01 200, are a five-adjustment push-button slip joint pliers. The pliers offer a gripping capacity for diameters and widths across the flats from 5/32" to 7/8" with just the push of a button as well as front and side gripping areas. The front gripping area is ideal for gripping stripped screws and bolts while the jaws of the side gripping area feature opposing teeth that allow the TwinGrip to grip round, square and hex materials with maximum force.

CATEGORY: Hand Tools

Circle 95 on card or click "PTEN e-inquiry" on VehicleServicePros.com



TOPDON®

THE ALL-IN-ONE AUTO-TECH TOOL



Phoenix Max

ADAS
Heavy-Duty Trucking
Key Programming



WWW.TOPDON.US
400 Commons Way, Suite A
Rockaway, NJ 07866-2030

TOPDON USA SUPPORT
SCHEDULE A DEMO 833-629-4832
SUPPORT@TOPDON.US



©2022 TOPDON USA Inc.

Circle 96 on card or click "PTEN e-inquiry" on VehicleServicePros.com

RAISING THE STANDARDS OF EXCELLENCE

AP SERIES™

*NEW 360-Degree Automatic Swing Arm Restraint System
Provides the Ultimate In Safety and Vehicle Fall Protection*



BendPak Model
10AP
Two-Post Lift



Certified to meet the
standards of ANSI/ALI
ALCTV: 2017



Bi-Metric Swing Arms

Our 10AP Series offers the convenience of wide or narrow installation wrapped up into one configurable package. This durable, safe, and reliable car lift features an expandable top beam and BI-METRIC™ arms to suit virtually every vehicle lifting requirement – symmetric or asymmetric. The 2-in-1 design gives operators the option of loading vehicles either symmetrically (centerline of vehicle at column) or asymmetrically (centerline of vehicle behind column). The simple, yet highly sophisticated is sure to keep operating costs low and productivity high. Check out the full line of 10AP lift series at bendpak.com or call us at **1-800-253-2363**.

1-800-253-2363 • BENDPAK.COM

©2022 BendPak Inc. All rights reserved.

BP BendPak®

BendPak®

YOU'RE INVITED

COME VISIT US!

SAVE BIG DURING THE SHOW

NOV 1ST - 4TH, 2022

SEMA

SHOW



LAS VEGAS
CONVENTION CENTER

WE'LL BE AT 2 CONVENIENT LOCATIONS

SEMA and BendPak are back again, and we're coming in loaded with an amazing display of world-class equipment. Get up close and personal with some of our top brands, like QuickJack and Autostacker and of course, legendary BendPak lifts. When you need a break from the heat, stop by our Cool Boss exhibit and chill out with our new COOLBLAST and COOLBREEZE Series! We couldn't fit it all in one booth, so be sure to look for us out front by the racetrack, and upstairs in the south hall. See you there!

SEE LIVE DEMOS!



WIN PRIZES

Inside Booth #37117
South Hall Upper



Outside Booth #81030
Silver Lot



CHECK OUT OUR
NEWEST PRODUCT!

ERGO-RS
Adjustable-height rolling work seat



COOL BOSS™ QUICKJACK™ AUTOSTACKER™ ergochair™

1-800-253-2363 • bendpak.com/SEMA

© 2022 BendPak Inc. BendPak is a registered trademark.

BP BendPak

Circle 97 on card or click "PTEN e-inquiry" on VehicleServicePros.com



Hunter Engineering
 Collision Alignment System
 The **Collision Alignment System** from **Hunter Engineering Company** features a diagnostic workflow designed specifically for collision shops. At the heart of the Collision Alignment System is Hunter's WinAlign17 software. Collision Alignment automatically guides the technician through a workflow of five essential diagnostic measurements, blueprinting the full alignment before work begins.

The five measurements are toe out on turn, maximum steer, ride height, suspension body dimension audit, and steering axis inclination.

CATEGORY: Body Shop
Circle 98 on card or click "PTEN e-inquiry" on VehicleServicePros.com



Bosch
 SMT 500 Leak Tester

The **Bosch SMT 500 Leak Tester** is designed to find all kinds of leaks in automotive applications including vacuum, EVAP exhaust, oil, manifolds, EGR valves, seals, gaskets, brake vacuum hoses, cooling systems, wind and water leaks, and more. Utilizing an on-board micro air compressor, the SMT 500 eliminates the need for an external compressed shop air source so technicians can quickly diagnose, locate and repair leaks whether the repair job is across the service bay or across town. The variable flow control and OEM-approved smoke agent can help detect leaks as small as 0.01" in low pressure sealed systems.

CATEGORY: Diagnostic Equipment
Circle 99 on card or click "PTEN e-inquiry" on VehicleServicePros.com

UP TO 80% SLOWER RETRACTION

INNOVATING SAFETY



COXREELS

EZ-COIL **SAFEST REELS**
 PATENTED REWIND SYSTEM **IN THE INDUSTRY.**

- ✓ Eliminate dangerous whipping hazards.
- ✓ Requires no external power source.
- ✓ Wide array of reel models & options to increase worksite efficiency & safety.

DURABLE. RELIABLE. HOSE, CORD, & CABLE PRO GRADE REELS

► SOLUTIONS FOR: WATER | AIR | POWER | HYDRAULIC | PNEUMATIC | VACUUM | WELDING AND MORE

MADE IN THE USA **www.COXREELS.com**



Circle 100 on card or click "PTEN e-inquiry" on VehicleServicePros.com
50 PTEN  **OCTOBER 2022**  www.VehicleServicePros.com

Snap-on

Phantom Auto-Darkening Welding Helmet with Light, No. WELDIGNPHNTM

The **Snap-on Phantom Auto-Darkening Welding Helmet with Light**, No. WELDIGNPHNTM, features a compact design to fit into tighter workspaces and offers a 180-degree viewing area with 10 peripheral-vision enhancing side lenses. The helmet's true color technology is brightened with a multi-function, pivoting, flip-out light that can be used when the helmet is raised or lowered and fully integrates into the contour of the helmet when not in use. Extra-large, four-sensor ADF is solar-powered with a lithium battery back-up and a patented user-friendly, quick-adjust push button ensures welders have a comfortable fit.

CATEGORY: Safety & Personal Gear
Circle 101 on card or click "PTEN e-inquiry" on VehicleServicePros.com



PTEN 
PEOPLE'S
2022 CHOICE



Hunter Engineering
 ADASLink Diagnostic
 Scan Tool
 The **ADASLink Diagnostic
 Scan Tool** from **Hunter
 Engineering** features ADAS
 calibration and secure FCA

gateway capabilities. This complete solution integrates with
 Hunter's WinAlign software, providing the technician with quick access
 to specific calibration procedures for more than 25 million vehicles.

ADASLink guides the technician with step-by-step onscreen instruc-
 tion, ensuring the calibration is completed accurately and according to
 OE requirements. The tool also provides thorough pre- and post-scan
 insurance documentation through HunterNet 2. Dynamic calibrations
 are supported by ADASLink alone, while ADASLink combines with the
 DAS3000 for static calibrations, using built-in cameras and rear wheel-
 mounted targets to remove the need for string, plumb bobs and tape
 measures.

CATEGORY: ADAS

Circle 102 on card or click "PTEN e-inquiry" on VehicleServicePros.com

ALLDATA

Instructor Toolkit

The **ALLDATA Instructor**

Toolkit is a resource for
 automotive and collision
 career and technical edu-
 cation (CTE) programs.

The Instructor Toolkit was
 developed in partnership
 with the ASE Education
 Foundation and aligns 100
 percent with ASE standards.

The toolkit includes clear,
 step-by-step instructions,
 goals, and objectives; tasks

for students that mirror the Task List at the end of the ASE Standards
 guide; and vehicle examples (specific to year/make/model/engine)
 and navigation path to the required information.

CATEGORY: Training

Circle 103 on card or click "PTEN e-inquiry" on VehicleServicePros.com



NO MORE CLUTTERED SOCKETS
LOCK-A-SOCKET

Available in Metric and SAE

www.MechanicsTimeSavers.com



MTSLAS50SO Tools Not Included

Available in:
 Metric & SAE
1/4" DRIVE Holds 13 Sockets
3/8" DRIVE Holds 14 Sockets
1/2" DRIVE Holds 16 Sockets
 Black, Orange, Green or Red

PTEN 
PEOPLE'S
2022 CHOICE



Lawson Products

Torrent Parts Washer

The **Lawson Products Torrent Parts Washer** combines the triple-action cleaning power of heat, chemistry, and pressure. It uses a water-based, solvent-free surfactant blend, reducing employee risk while cleaning 90 percent of parts within one minute, according to the company. The aqueous cleaning solution is heated to 131 degrees F, activating the aqueous cleaners and loosening oils and greases. The cleaning chemistry produces zero VOCs and leaves behind a rust inhibitor for maximum protection of parts. Then, tough deposits are blasted away by pressure. A notable feature is that the pressure and solution can be directed by the user where needed.

CATEGORY: Shop Equipment

Circle 105 on card or click "PTEN e-inquiry" on VehicleServicePros.com



EXAIR Corporation

VariBlast Precision

Safety Air Gun

The **Exair VariBlast Precision Safety Air Gun with Nano Super Air Nozzle** is a CE compliant lightweight air gun with an engineered variable flow trigger able to produce variable force upon a target simply by pulling the trigger. The air gun has a built-in full finger trigger, convenient hanger loop, and its body is made of high impact, glass reinforced nylon. It's available with a standard 12" or 20" extension, which can also be outfitted with an impact resistant polycarbonate chip shield. The 1/4 NPT air gun produces 75 dBA noise level and the Nano Super Air Nozzle requires only 8.3 SCFM, and is made of Type 316SS or PEEK thermoplastic.

CATEGORY: Air Tools

Circle 107 on card or click "PTEN e-inquiry" on VehicleServicePros.com

IT'S LEAN. IT'S MEAN. IT'S GREEN.



FORNEY® 4 1/2" ANGLE GRINDER

AVAILABLE NOW



FORNEYIND.COM 

Circle 106 on card or click "PTEN e-inquiry" on VehicleServicePros.com



FOR MORE INFORMATION ON THESE PRODUCTS, CLICK ON "PTEN E-INQUIRY" at VehicleServicePros.com OR CIRCLE THE NUMBER ON THE CARD.

2022
GREAT PRIZE
GIVEAWAY

TIME IS RUNNING OUT!

★ Win these prizes at VehicleServicePros.com/GPG ★

Entries close October 31st



AirCat Tool Giveaway

Prize value: \$500



Autel ITS600 Sensor Kit

Prize value: \$965



BOSCH SMT 500 Smoke Machine Leak Tester with built-in Air Compressor

Prize value: \$1,972



COAST Bright Light Bundle

Prize value: \$715



Gray 7-THF Vehicle Support Stands

Prize value: \$500



OEMTOOLS Oil Service Prize Pack

Prize value: \$649.96



Induction Innovations

Mini-Ductor Venom HP + Coil Kit

Prize value: \$736.50



KTtool

Deluxe Mechanics Tool Set

Prize value: \$3,600



Lang Tools

Made in USA Specialty Tools

Prize value: \$550



Launch Millennium MAX Scan Tool

Prize value: \$799



XTools USA Nitro LT & Auto Keys

Prize value: \$2,250



Oasis Scientific ME-610i Borescope

Prize value: \$900



Opus IVS

Mongoose-Plus J2534 Device

Prize value: \$495



OTC Ball Joint Connected Adapter Professional Kit

Prize value: \$2,140



ProMAXX Ford 3.5 EcoBoost Exhaust Manifold Repair Kit

Prize value: \$613.25



ToolAid Electrical Diagnostic and Repair Pack

Prize value: \$615



StreamLight 2022 Worklights Prize

Prize value: \$750



TEXA Nano S, IDC5 Car and Tablet

Prize value: \$4,495

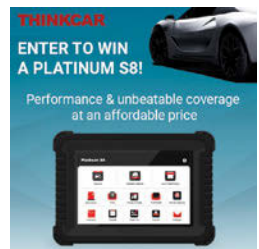

ThinkCar Platinum S8

Prize value: \$1,249

BROUGHT TO YOU BY:

PTEN
PROFESSIONAL TOOL & EQUIPMENT NEWS

MOTOR AGE

ABRN
AUTO BODY REPAIR NETWORK

VEHICLESERVICEPROS.COM



▲ Austin Matney

in California, where he works now as an equipment mechanic II (he was promoted two years ahead of schedule). It was his supervisor, Frank Palmer, fleet services supervisor, who nominated Matney for the *Motor Age* and *PTEN* Best Young Tech Award because he has been incredibly impressed by this young man since the day he interviewed for the job.

“He blew me away,” Palmer says. “As a 22-year-old, his maturity, knowledge, and awesome attitude are very impressive.”

Matney, now 23, started out doing simple preventative maintenance on basic fleet equipment but quickly displayed his skills. The fleet of 454 pieces of equipment and six technicians went from 12 percent preventative maintenance compliance to 98 percent in Matney’s first six months on the job, and they completed 1,007 backlogged repairs. His throughput increased 54 percent since he started at the city about a year and a half ago.

“We all knew what we had to do,” Matney explains. “There was a big list of what was behind, so we all got on the same page and upped our workload to a different level than what we were at before,” Matney explains. “Sometimes we would skip breaks to make sure the jobs got done and just putting our heads down and getting through it; working at a lot faster pace than normal, but not without reducing the quality of work.”

STEPPING UP TO THE CHALLENGE

Over the last six months, Matney has been running the heavy side of Palmer’s shop, and then he was moved over to Fire Apparatus Preventative Maintenance and Repair. This spot is normally reserved for Palmer’s top technician, but Matney stepped up to the challenge “never grumbling or complaining, just showing results.”

For example, Matney has “single-handedly led the charge” on keeping the city’s one and only ladder truck up

Austin Matney wins 2022 Best Young Tech Award

His quality of work and can-do attitude set this young tech apart from the rest.

By **Amanda Silliker**, Contributing Editor

Austin Matney has been turning wrenches for as long as he can remember. When he was a little kid, he was always trying to “fix” his bike or skateboard and later helped his dad work on ATVs and UTVs. At age 15, he started working part-time for his now father-in-law at his mobile semi-truck repair business.

“I would do odds and ends stuff for him after school, trying to learn, and I couldn’t get enough of it,” he says.

Then at 17, he got a full-time job working for his now father-in-law’s brother who had an auto repair shop near his hometown in Camarillo, Calif. He worked there during the day and still worked after hours on heavier duty repairs with his father-in-law. After doing this for five years, Matney applied at the City of Ventura

Marquee Sponsors



Supporting Sponsors



and running, Palmer says. This includes several “NASCAR-style” preventative maintenance and repairs in order to get this important piece of equipment back on the roads as quickly as possible.

When the truck needed a full transmission swap, Matney gave Palmer the confidence as a fleet supervisor to let his team do it rather than sending it out to an



GRAND PRIZE

As the winner of the Best Young Tech Award, Austin Matney received the following prize pack: Roundtrip flight and lodging for two nights for the AAPEX/SEMA shows in November in Las Vegas; a trip for two to Vision 2023 and a one-year subscription to the Virtual Training Academy from Carquest Technical Institute and WorldPac Training Institute; and the Autel MaxiSYS MS906TS scan tool.

outside vendor. The team completed the job in eight days versus the nine weeks they were quoted from a vendor.

“I decided to trust my mechanical knowledge, and the guys around me,” Matney says. “I knew as long as we work together and push through it, I knew we could get it done.”

Also, Matney did a full engine swap on an older truck by himself with minimal guidance while reprogramming the unit utilizing the new Ford Diagnostic Software. He thoroughly enjoys tackling challenges in this line of work and loves problem-solving.

Matney always wanted to work on fire trucks and really enjoys learning and understanding how they work, in addition to providing a valuable service to his community.

“Helping to make sure our public service workers and emergency vehicles are good on the road and able for their operators to do their jobs — that’s what I am the most proud of about working here,” Matney says.

WORK QUALITY

According to Palmer, Matney’s quality of work is that of a seasoned mechanic. He is a smart, methodical technician that takes his time to ensure his maintenance and repairs are completed properly. Matney has had zero units come back for rework in the past 180 days.

“He continually strives to be the best at his craft,” Palmer says. “I have been in the fleet business for almost three full decades, and he has exceeded all of my

AUSTIN MATNEY’S TOP 5 FAVORITE TOOLS:

- 1” impact wrench by Ingersoll Rand
- 1/2” ratchet by Snap-on
- 1/2” electric impact wrench and 3/8” electric ratchet by Milwaukee Tool
- Sockets and wrenches by Snap-on and GEARWRENCH
- Snap ring pliers by Snap-on

REMOVING RUSTED AND OBSTRUCTED DIESEL NOx AND PARTICULATE SENSORS DOESN'T HAVE TO BE AN EXPENSIVE AND TIME CONSUMING PROBLEM ANYMORE!

LT996D Shockit™ Socket Diesel NOx & Particulate Sensor Removal Kit

- Air hammer powered Shockit™ Sockets for removing rusted and obstructed diesel exhaust sensors
- Compact sizes for reaching sensors with restricted access
- Uses the force and vibration of an air hammer to loosen the most rusted sensors
- Includes non-turning offset 8mm radius tip LT1910P 11” Standard Shockit™ Punch
- Force and vibration of air hammer allows most sensors to be removed without thread galling
- Each Shockit™ Socket has 3 driving ears w/ 8mm indexed holes for delivering maximum rotational force
- Each Shockit™ socket has inverted indexed holes for tightening and loosening, allowing the most stubborn sensors to be worked back and forth during removal
- 22mm Shockit™ Socket removes NOx sensors on Chevy® Duramax, Dodge® Cummins, Ford® Power Stroke. Also removes most Semi Truck NOx sensors including Kenworth®, Cummins®, International®, Detroit & Volvo®
- 22mm Low Profile Shockit™ Socket for delivering maximum rotational force and minimum side loading for extremely stuck NOx sensors
- 22mm Thin Wall Deep Shockit™ Socket removes NOx sensors on Jeep® & RAM® ECO Diesel
- 24mm Shockit™ Socket removes Particulate Sensors (Soot Sensors) on Chevy® Duramax, Dodge® Cummins and Ford® Power Stroke
- 24mm Low Profile Shockit™ Socket for delivering maximum rotational force and minimum side loading for extremely stuck particulate sensors
- 30mm Shockit™ Socket removes the NOx sensor lock nuts on Jeep® and Ram® ECO Diesel
- Includes 20mm, 22mm & 27mm bottoming tap and dies for sensor and mounting hole threads
- Must be used with Shockit™ Punches for maximum performance and warranty coverage
- Additional Shockit™ Punches sold separately - LT1910PS 5.5” Short Punch, LT1910PL 22” Long Punch

AIR HAMMER POWERED

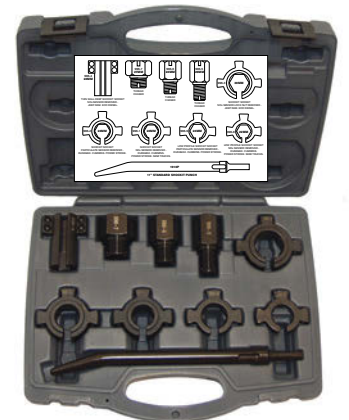

Patent #7,677,143

NEW PRODUCT

996-3

996-4

996-9

EASILY REMOVE & INSTALL BENDIX/KNORR-BREMSE AIR DISC BRAKE PAD RETAINERS!

LT891 Bendix/Knorr-Bremse Air Disc Brake Pad Retainer Tool

- The only tool made for servicing Bendix/Knorr-Bremse air disc brakes
- Provides safer and easier way to remove pad retainer
- Works with left and right side calipers
- Heat treated for strength and durability
- Designed to work with or without caliper shield
- Easy grip handle



Scan to see tool work!



Patent pending

NEW PRODUCT



LOCK TECHNOLOGY, INC.
Toll Free 800-421-7241



Innovator of Great Ideas

www.ltitools.com
ltitools@ltitools.com

Circle 108 on card or click “PTEN e-inquiry” on VehicleServicePros.com



expectations in his ability to complete repairs right the first time.”

Matney adds he is “almost OCD” about double and triple checking his work to prevent comebacks.

“It’s replaying the process through in my head,” he explains. “Making sure I have every line hooked up, every bolt tightened, no matter if it takes the extra 20 or 30 minutes or so, just making sure that when it leaves our shop it’s in the best shape it can be.”

ATTITUDE

Matney’s “can-do attitude” really sets him apart on the team. Palmer says he is often chosen over more senior technicians to complete complex repairs because of his impressive diagnostic skills, technical prowess, and positive attitude.

“Since I was born, my dad has always instilled a good work ethic in me,” he notes. “Whether it was sports, or school,

RUNNERS-UP:

Be on the lookout, starting December 2022, for the first online exclusive interview featuring one of the talented top nine runners-up for this year’s Best Young Tech Award. Throughout the year, *PTEN* and *Motor Age* editors will be chatting with the top nine to get the inside scoop on how these techs have come to thrive in the industry. The top nine include the following:

- | | |
|------------------------|---------------------|
| 1. Josh Whiteman | 6. Jessica Areizaga |
| 2. Brandon Laguire | 7. Hazem Tugan |
| 3. Cody Rennison | 8. Devon Jones |
| 4. Brandon Ludwikowski | 9. Ryan Jackels |
| 5. Jonathan Wasilewski | |

or any other aspect in life, just giving it 100 percent all the time, and even if things get tough, or you face some adversity, just keep pushing through.”

His father-in-law had a big influence here as well by always encouraging him to take a step back and look at the job with a clear head.

“It’s important to think things through instead of getting worked up and possibly

messing up the job you’re working on,” Matney says. “Being a mechanic, you can face jobs that just get into your head mentally.”

Palmer says Matney is the cornerstone of the new legacy of the fleet at the city — since 66 percent of technicians recently retired — and he is a breath of fresh air.

“He is the poster child of going from the past days of being a mechanic to being a modern-day technician.” ❌

Diagnostic Problems? We’ve got your back

194 Super Relay Buddy®

- Full 7 Amp load during the test
- Relay voltage drop monitored
- **Ten second test!**
- Test results displayed as red, green or yellow for caution
- Tests 7 different 12 volt relays
- Improved & more effective test finds intermittently bad relays



New Products!



50 YEARS in business



195 Super Relay Buddy® Pro Kit

- 10 second test - this is **THE** quickest way to test relays
- **Pro Test Kit** includes adapters for expanded test coverage - 10 different 12V relays

Call 800-227-1603 for more info - www.esitest.com



Circle 109 on card or click “PTEN e-inquiry” on VehicleServicePros.com

WORK MEETS COMFORT

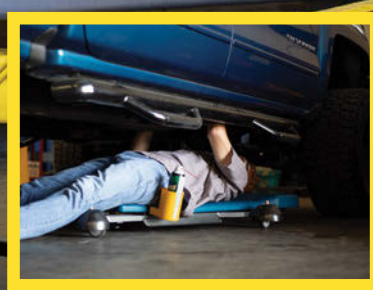

ROLLING CREEPER SEAT CONVERTS FROM HIGH TO LOW

The **ergochair™** is the adjustable height rolling work seat which will make performing awkward work tasks ergonomically easier and safer. This comfortable creeper seat offers a full range of mobility, increased productivity, and reduced fatigue. To Learn more visit bendpak.com/ergochair

UP TO **6** LOCKING HEIGHTS

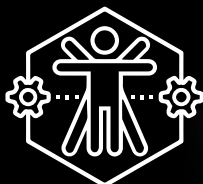

TRANSFORMS COMFORTABLY FROM CREEPER TO UPRIGHT SEAT



1-800-253-2363 • BENDPAK.COM

©2022 BendPak Inc. All rights reserved.

 **ergochair™**

Circle 110 on card or click "PTEN e-inquiry" on VehicleServicePros.com

The Flat Rate Master joins the *PTEN* team!

Mike Berg, better known as the Flat Rate Master, is being welcomed to the *PTEN* family as part of our social influencer partnership.



FIND MIKE & *PTEN* ON



FACEBOOK

facebook.com/flatratemaster
facebook.com/ptenmagazine



INSTAGRAM

@flatratemaster
@ptenmagazine



YOUTUBE

FlatRateMaster
PTEN (Professional Tool
& Equipment News)



TIKTOK

@flatratemaster

Mike Berg, who you may know as the Flat Rate Master, got into the auto repair industry out of necessity, he says.

“I was lower middle class, and I had to fix my own cars so I could get to work — and I found that I was good at it, and I enjoyed it,” he explains.

After graduating from the Carroll Tech automotive repair program, he repaired garbage trucks, worked in sales for a couple equipment manufacturers, and then spent the rest of his career in automotive repair shops. Now, he is the shop foreman at Anthem Automotive in Atlanta.

Throughout his career he always tried to position himself as a mentor in the shop.

“If the kids are asking questions, I’m always trying to help them,” he adds.

Five years ago, Berg was watching YouTube in his spare time, and he saw a gap in automotive repair industry for video content. He wanted to create a channel exclusively for professional technicians and those training to become one. Other channels he noticed were catering more to the DIY segment.

“I saw the need because so many young kids in this industry come in, and they don’t get the help they need at their shop, so I started the channel really to help those kids working in auto repair,” he says.

Berg talks about many different tools on his YouTube channel and is a self-described tool junkie.

“To say I love tools is an understatement,” he says. “I have two 6’ long Matco toolboxes full, and two roll carts, and some tools in storage. It’s always an obsession of mine. I’m always trying to find a better and faster way to do my job.”

Right now, his favorite tools are the Milwaukee quarter-inch extended reach electric ratchet; the Launch Tech Throttle III scan tool; and the Matco quarter-inch impact swivels.

Berg says the best part about being an automotive technician is the challenge.

“It’s always different; you never know what you’re going to get,” he notes. “You pull a car in with a check engine light, it’s a bad gas cap, the next one is a communication problem, so it’s always interesting.” ❌

Hunter Engineering Revolution Tire Changer with HunterNet 2 Connectivity

Use the tire machine to collect back end data and gain business insight.



PTEN: How does this tire changer improve the lives of technicians and shop owners?

JH: One of the biggest things is as these wheels and tires get more and more expensive, technicians must document things like damage, scratches on the wheel, tire bulges or whatever they might encounter as they're servicing the assembly, so the HunterNet 2 connectivity gives them a super easy way to do that right on the machine, right as it's spotted (there's no need to remember it and write it down elsewhere on the repair order). It also automatically records things like billable procedures, such as force matching and bead massaging that are really crucial to a good ride quality.

Most shop owners/managers are interested in equipment ROI — how it's being utilized, its payoff, etc. The HunterNet 2 connectivity being expanded to the tire changer allows a view into how that machine is being used, what its ROI is, and it gives a good aggregated look into tire sizes and wheel sizes that are being serviced. Depending on the shop owner's system, it's great insight to have. You can see what procedures are being used, what tire sizes or wheel sizes are being serviced to help drive tire stocking decisions. The HunterNet 2 screen offers that on one chart, so you can take a look at that at a glance and say, "Oh, maybe I need to stock more 18" tires." So, it gives it a really interesting insight there. 

We will be featuring one of our Innovation Awards winners that scored among the highest in the group each issue. This month, we are profiling the Hunter Engineering Revolution Tire Changer with HunterNet 2 Connectivity. This product allows shops to keep convenient count of the number of tires changed, measure shop activity and productivity, and note trends over any period of time. We sat down with Hunter's project manager, Jim Hudson, to learn more.

PTEN: What makes this product innovative?

Jim Hudson: It really is the world's first smart tire changer. No other tire changer can report its own usage to the cloud. The data it can accumulate includes things like service time, wheel size, what procedures were used, air pressure, inflation pressure, and even things like the year, make, and model. Even technician comments, things like that, can be entered in at the anytime throughout the service procedures, so when you couple all of that all that data with the power of HunterNet 2 to sort of filter that, it's a really powerful pair.

PTEN: How did this product come about?

JH: It was a natural progression as we expand the HunterNet 2 to other types of equipment. First, it was alignment machines, inspection machines, things like that, but tire changers have long been this blind spot — they always sit back there and they do their jobs — but we're seeing there's a lot of data available there. We complete that picture with the Revolution Tire Changer, which is already software driven. It has a big touchscreen interface, so we can enter those technician comments and things easily in the machine. We can bundle all that data.

CATEGORY SPOTLIGHT

TOOL STORAGE

Although, tool storage often carries a higher price tag, having the right solution not only helps you stay organized so that you can work more efficiently but also keeps your tools protected from the elements ... and from other users. Are your tools organized, or do you often find yourself scrambling to find a tool you swore you had just used the other day? Whether in the market to buy or not, here are some solutions we think are worth checking out.



FEATURES A WOOD WORKTOP AND 10 DRAWERS

The **Beta Tools RSC28 SuperTank Tool Trolley** features a wood worktop and 10 drawers with ball bearing slides. It has a quick, safe system for opening and closing drawers, and the drawer bases are protected by foamed rubber mats. Other notable features include two centralized safety locks, four high-capacity castors (two fixed and two steering with brakes), four bottle holders (two front and two rear), six side tote trays, a side compartment with foldaway door with lock, and a 5.3" high storage compartment with a plastic-covered base. It has a static load capacity of 2,646 lbs, and is available in three colors.

Circle 111 on card or click "PTEN e-inquiry" on VehicleServicePros.com



Watch this product in action here:
VehicleServicePros.com/21280115



TRAY SECURES TO ANY STEEL SURFACE

The **Olsa Tools 27-pc 3/8" SAE Socket and Magnetic Socket Organizer Set**, No. 1436, enables technicians to store deep and shallow chrome sockets in a drawer or mounted to the side of their toolbox. With its ferrous magnetic base, the socket holder is able to keep the sockets in the tray and the tray secured to any steel surface. The 3/8" chrome sockets include SAE sizes in deep and shallow profiles from 1/4" to 1" with every 1/16th of an inch: 1/4, 5/16, 3/8, 7/16, 1/2, 9/16, 5/8, 11/16, 3/4, 13/16, 7/8, 15/16, and 1". The six-point sockets feature large, easy-to-read stamped markings for instant identification and are constructed from Cr-V steel for strength and durability.

Circle 112 on card or click "PTEN e-inquiry" on VehicleServicePros.com



AVAILABLE IN THREE CONFIGURATIONS

The **Ernst Manufacturing Bit Bar** is designed to provide an ideal solution for bit sets and will mount magnetically on the sides of toolboxes, top of chest lids, or in drawers. It can also be used for stationary or portable storage. With three configurations available, the Bit Bar is able to hold a combination of short and long bits in one easy place. Options include 60, 78, or 96 tool capacities. Bits are held firmly with taper lock holes and will easily release when pulled out. Available in red/black or black/Hi-Vis. Made in the U.S.A. and comes with a lifetime guarantee.

Circle 113 on card or click "PTEN e-inquiry" on VehicleServicePros.com



INCLUDES 34", 42", 59", 73", AND 128" CABS AND WORKSTATIONS

The **SP Tools USA Sumo Series Toolboxes** feature double wall super-duty construction using 14.5-gal steel. Users can charge cordless tools, lighting, and diagnostic equipment with SP Tools' power system that is integrated throughout each box. Each storage system has spring-loaded super-duty casters where each caster is capable of supporting 881 lbs. The drawer slides are rated at 120 lbs per drawer and 240 lbs per drawer on the wider and deeper drawers. The new drawer retention system has an easy one-touch single-handed release and open function. Additionally, the Sumo Series hatches offer an increased head clearance height of 6' 1". Series includes 34", 42", 59", 73", 114", and 128" cabs and workstations.

Circle 114 on card or click "PTEN e-inquiry" on VehicleServicePros.com



Watch this product in action here:
VehicleServicePros.com/21258884



DURABLE, FUNCTIONAL, AND VERSATILE FOR TECHNICIANS

The **K-Tool International 55" Premium 10-Drawer Double-Bay 500 lb Tool Box** is durable, functional, and versatile for technicians, from entry-level to senior level. With 10 drawers, it has roller-bearing slides and anodized aluminum drawer pulls. Designed with a gas-assist lid and integrated UL power strip, this multiple-drawer tool storage features a durable powder-coat finish and comes fully assembled.

Circle 115 on card or click "PTEN e-inquiry" on VehicleServicePros.com



FOR MORE INFORMATION ON THESE PRODUCTS,
CLICK ON "PTEN E-INQUIRY"
at VehicleServicePros.com
OR CIRCLE THE NUMBER ON THE CARD.

CATEGORY SPOTLIGHT



Tool Storage

CAN ATTACH TO ANY CORNWELL PLATINUM ROLLER CABINET OR PLATINUM CART

The **Cornwell Quality Tools Platinum 29" Power Crib Side Cabinet** can attach to any Cornwell Platinum Roller Cabinet or Platinum Cart. The cabinet comes with 6" by 2" spring-loaded, heavy duty polyurethane crowned casters with a 1,500 lb caster rating. The drawer is supported by 440 lb capacity roller bearing slides and features panels that accept tool organizing accessories for customization. The unit comes with an electric power strip with five standard outlets (110V type B sockets) and two USB outlets (2.0A), are positioned in the drawer and provides power for cordless and diagnostic tools.

Circle 116 on card or click "PTEN e-inquiry" on VehicleServicePros.com



ALLOWS FOR SIMPLE VISUAL INVENTORY CONTROL

The **Shadow Tool Staging System TSS 6.5** is designed to simplify tool selection/return, saving technicians on time and reducing physical motions while making tool inventory control simple. The TSS 6.5 openly presents tools in dedicated positions, allowing visual cues and barrier-free tool selection. The compact system measures 6'5" height by 30" depth by 36" width and sits on 8" wheels. The unit expands with large panels sliding out to 90" in width, exposing shelves, custom accessories, power (110, USB, 12V), battery charging drawer, plus laptop mounting options. It was designed to speed repair times, track tools easily, and reduce mechanic fatigue to help increase bottom line profits.

Circle 117 on card or click "PTEN e-inquiry" on VehicleServicePros.com



Watch this product in action here:
VehicleServicePros.com/21280899

REMOVABLE INTERNAL COMPARTMENTS

The **VIM Tools Small Interlocking Storage Case with Compartment Inserts**, No. SCS, contains eight small containers and four large containers to store bits, fasteners, repair kits, and many other things that need organizing. The internal compartments seal to inside of lid, allowing everything to stay in its designated spot, even if the container is flipped upside down, the company says. With a ridged lid and bottom, multiple cases to be stored on top of each other and stay in place. Additionally, the internal compartments are removable and the case is made of heavy duty polymer, making it shock and crack resistant.

Circle 118 on card or click "PTEN e-inquiry" on VehicleServicePros.com



ALLISON APPROVED Heavy Duty Heated Transmission Component Flusher with ADJUSTABLE FLOW RATE

The **Flo-Dynamics TTCF-9A** Variable High Flow Hydraulic System Flusher will flush and clean transmission coolers and lines or any hydraulic system of contamination, sludge, varnish deposits, and particles. The TTCF-9A, with an adjustable flow rate from 1-8.5 GPM, was specially developed to service both automotive and heavy duty transmission cooling systems in one machine! A non-variable **TTCF-9B** base unit is also available for lower volume shops. Allison approved!

FLUSH COMPLETE			
Run Time: 0:15:44.4			
T: 140	F: 136	START	STOP
P: 75	PSI	54	PSI
F: 5.60	GPM	7.20	GPM

Flush cycle results displayed live

- Reverser valve allows easy flow reversal without removing service hoses
- Air injection agitates the system, creating a scrubbing action to remove trapped debris and solidified waxy varnish
- Selectable flush cycles; choose from continuous or 15-120 minutes with or without air injection



PATENT PENDING

For more information, please visit www.flodynamics.com

Circle 119 on card or click "PTEN e-inquiry" on VehicleServicePros.com

CATEGORY SPOTLIGHT

Tool Storage



FOR MORE INFORMATION ON THESE PRODUCTS,
CLICK ON "PTEN E-INQUIRY"
at VehicleServicePros.com
OR CIRCLE THE NUMBER ON THE CARD.

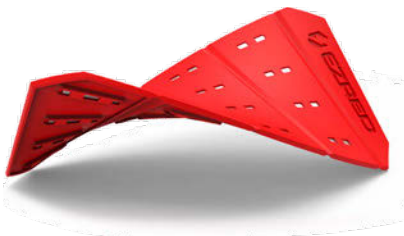

HOLDS TOOLS TO CURVED OR TILTED FERROUS SURFACES

The **EZRED MAGMAT Magnetic Flexible Tool Mat** is a multi-purpose tool organizer that holds parts and tools to any curved or tilted ferrous surface. Made of non-marring TPEE material, the tool mat will fold, bend, or roll any way needed while always returning to its original shape. Its strong neodymium magnets hold tools, hammers, wrenches, sockets, drill bits, nuts, bolts, and more. The MAGMAT also features a low profile with a large surface area. It measure less than 1/4" tall and is 8.75" in length and 5.5" in width.

Circle 120 on card or click "PTEN e-inquiry" on VehicleServicePros.com



FULLY-CUSTOMIZABLE MODULAR DESIGN

Lyon's line of **EVO Workbenches** are designed to provide a fully-customizable solution for automotive service technicians. With a modular design, the workbenches are able to change and evolve over time, allowing technicians to upgrade even after installation. The workbenches feature fully-welded steel housings and the phenolic resin drawer fronts resist chemicals and eliminate scratches and dents. The EVO workbenches are durable and are made to last.

Circle 121 on card or click "PTEN e-inquiry" on VehicleServicePros.com



CAN BE CONFIGURED IN MORE THAN 50 COMBINATIONS

The **Bauer Modular Storage System** from **Harbor Freight** can be configured in more than 50 combinations. The durable, interlocking system features three toolboxes, one storage tote, and one organizer, and can be easily maneuvered around rugged areas providing versatility and mobility. The base of the modular system is a rolling toolbox with large, smooth-rolling wheels and an extendable handle with a comfort grip. The organizer is ideal for small tools, accessories, and parts, offering 12 removable trays and a transparent lid. The tote is easy to carry with two side handles and has a weight capacity of up to 50 lbs.

Circle 123 on card or click "PTEN e-inquiry" on VehicleServicePros.com

Lead Acid, Lithium or Capacitor CHOOSE THE BRAND THAT MEANS POWER

JUMP n Carry.



Jump-N-Carry jump starters are ideal for use in a wide variety of jump starting environments, including automotive, marine, fleet and industrial. Extreme jump starting power, long cranking duration and extended service life are the key features of **Jump-N-Carry**.

New lithium jump starters bring dependable power, valuable features and trademark durability to this class of product. New capacitor driven models are unaffected by the cold and can deliver endless jump starts on a single charge. Our lead acid models have been delivering the goods for technicians and shops for 25 years.

To learn more, visit our website at www.jumpstarter.com or call 800.328.2921.

Whether you rock it old school or prefer the new kid on the block, **Jump-N-Carry** means power, each time and every time you use it.



SECURELY HOLDS TOOLS IN PLACE

The **Mantis Toolgrid** is a series of patented tool holders and boards designed to organize and securely hold tools in place. Locating pins on the bottom of each holder fit into the holes of the Toolgrid board for a quick and easy set-up. The thousands of holes in each board gives users infinite layout possibilities. Once a set-up is complete the holders are secured to the boards with specially formulated T20 screws.

Circle 124 on card or click "PTEN e-inquiry" on VehicleServicePros.com



Circle 122 on card or click "PTEN e-inquiry" on VehicleServicePros.com

CATEGORY SPOTLIGHT

Tool Storage

Eliminate chaos and clutter with the **ORIGINAL** socket tray *invented* by Hansen Global.

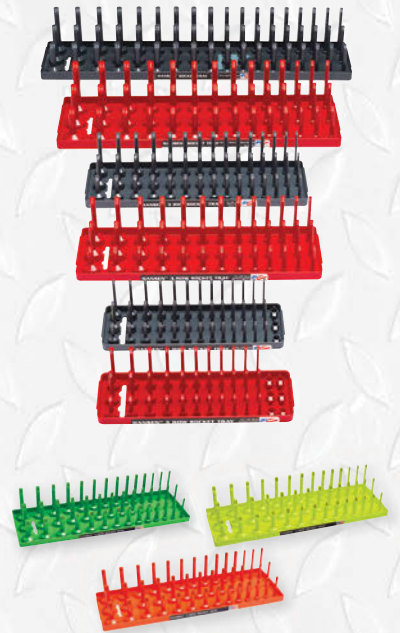

- Organize tools by size and style for easy identification.
- Secure regular, deep and semi-deep sockets all on one tray.
- All trays are molded from rugged ABS plastic to shrug off grease, chemicals, and other debris, and come with a lifetime guarantee.
- 3 row trays available in 1/2", 3/8" and 1/4" drive.
- 2 row trays available in red, gray, orange and green.



Proudly 100% made in the USA since 1995 – Lifetime Guarantee.

877-793-5213

hansenglobalinc.com

Circle 129 on card or click "PTEN e-inquiry" on VehicleServicePros.com

SECURELY HOLD SOCKETS AND METAL TOOLS

The **Ullman Devices Magnetic Rails**, Nos. UMR13 and UMR17, use strong N35 magnets to mount to benches, boxes, and vehicles to securely hold sockets and metal tools. The rails also have mounting holes to adhere to walls and other non-magnetic surfaces. The UMR13 measures 13-1/4" in length while the UMR17 measures 17-1/4" in length.

Circle 125 on card or click "PTEN e-inquiry" on VehicleServicePros.com



STORES AND ORGANIZES 75 SAE AND METRIC SOCKETS

The **OEMTOOLS 6-Pack Set Metric and SAE Magnetic Socket Organizers**, No. 22488, are ideal for tool organization, as they are designed to fit snug into tool chests. All six socket organizers fit both deep and shallow sockets. The set comes with three organizers with metric markings and three with SAE markings. They are able to store and organize a total of 75 SAE and metric 1/4", 3/8", and 1/2" drive sockets without spills, as each one has a strong magnetic non-marring, rubberized base. The organizers are available in either a red or blue color.

Circle 126 on card or click "PTEN e-inquiry" on VehicleServicePros.com

CUSTOMER REVIEW:
 “These hold a ton of sockets in about every size imaginable. The magnets hold the sockets in place and also hold the organizer itself in place when removing sockets and opening toolbox drawers. The markings are very easy to read.”



REVERSIBLE DOOR DESIGN

The **Homak Manufacturing 24" CTS Side Locker** includes two electrical outlets. Four drawers secured by lift latch drawer pulls to prevent drawers from opening. Two adjustable shelves to fit a variety of storage needs. Reversible door design. Durable stainless-steel work surface. Each drawer is fully extendable, can hold up to 100 lbs, and is lined with PVC foam. Has a UV protective high-gloss finish for a smooth look to the overall design.

Circle 127 on card or click "PTEN e-inquiry" on VehicleServicePros.com



OFFERS BOTH A LIFT AND SLIDE TOP LID

The **Mechanic's Time Savers Switch Cart** can be opened by sliding or flipping open, allowing users to utilize the top as a work surface while still being able to access their tools by sliding open. The cart measures 36" in width by 26" in depth by 45" in height. The top lid has 175-lb slides, the three drawers have 125-lb slides, and the lift-latch drawer pulls. The cart has 6" casters, heavy duty construction, and a power strip. It's available in three trim colors: black, red, and yellow.

Circle 128 on card or click "PTEN e-inquiry" on VehicleServicePros.com



CATEGORY SPOTLIGHT

Tool Storage



FEATURES METAL REINFORCED CORNERS

The **Milwaukee Tool PACKOUT 2-Drawer Tool Box**, No. 48-22-8442, has a 50 lb weight capacity and a locking security bar that allows users to padlock the drawers closed to keep them securely shut during transport. The portable toolbox with drawers is constructed with impact-resistant polymers, all-metal ball bearing slides, and metal reinforced corners for jobsite durability. The 2-Drawer Tool Box also allows users to customize their drawer layout with quick-adjust dividers (includes one set). The toolbox measures 16.3" by 22.2" by 14.3".

Circle 130 on card or click "PTEN e-inquiry" on VehicleServicePros.com



CUSTOMER REVIEW:

Great addition to the PACKOUT system. The drawers slide with ease, and I like the locking bar to prevent the drawers from opening during transport.



AVAILABLE IN 10 SIZES AND CONFIGURATIONS

The **GEARWRENCH Modular Tool Sets** consist of multi-piece assortments of GEARWRENCH tools, each organized in a sturdy EVA foam tray with high-visibility size markings. The chemical- and solvent-resistant trays are designed in modular sizes to work with the company's GSX cabinets and chests, allowing users to customize their own toolkit and storage system. The sets feature components selected to provide a complete range of specific tools, each nested in a custom laser-formed cutout that protects while keeping tools organized and accessible. The Modular Tool Sets are toolbox ready and come in 10 sizes and configurations from 18-pc sets to 83-pc sets.

Circle 131 on card or click "PTEN e-inquiry" on VehicleServicePros.com



Watch this product in action here: VehicleServicePros.com/21280762



INCLUDES A ZEUS DOCKING AND CHARGING STATION

The **Updated ZEUS Workstation** from **Snap-on** is now available in black and red to highlight the company's signature colors. The flip top workstation includes a ZEUS docking and charging station with a custom-fit organizer and space for a wireless keyboard and mouse, all stored safely in a lockable slide top. The 27" high-resolution touchscreen monitor has a tilting monitor bracket to get the right angle. The deep 12" drawer can accommodate a printer, while the two 3-1/2" drawers include organizers for standard and optional accessories, to maximize storage space. The updated cart provides the use of the ZEUS diagnostic and information system throughout the service bay.

Circle 132 on card or click "PTEN e-inquiry" on VehicleServicePros.com



SACRIFICE NOTHING

- Advanced Oil Grip, No Saturation
- 30% Lighter
- Exceptional Abrasion Resistance

GET A PAIR! FREE
magidglove.com/tritek-palm-pten

MAGID
Safety at work™

Circle 133 on card or click "PTEN e-inquiry" on VehicleServicePros.com

64 PTEN ○ OCTOBER 2022 ○ www.VehicleServicePros.com



AAPEX 2022
BOOTH NUMBER R7832
VENETIAN EXPO - LEVEL 1

NOVEMBER 1ST - 3RD 2022 | THE VENETIAN EXPO | LAS VEGAS, NV

aaapex

Circle 134 on card or click "PTEN e-inquiry" on VehicleServicePros.com



FOR MORE INFORMATION ON THESE PRODUCTS,
CLICK ON "PTEN E-INQUIRY"
at **VehicleServicePros.com**
OR CIRCLE THE NUMBER ON THE CARD.



MARKETPLACE

Contact James Hwang at JHwang@EndeavorB2B.com for advertising information.



FEATURES THE ICONIC RAT FINK CHARACTER

The **Matco Tools 34.5" 6 drawer MSC4 Rat Fink Rolling Tool Cart**, No. MSC4FDRFK22, features the iconic Rat Fink character who symbolizes the Hot Rod scene of the '50s and '60s. The tool cart includes full extension roller bearing slides, four corner bumpers that help prevent vehicle and cart damage, four 5" by 2" casters with two locking and two non-locking, and two gas pistons function for lid to automatically open and stay at the proper angle when unlocked. The overall dimensions of the cart are 34.5" width by 21.2" depth by 39.4" height, and the lid compartment height is 5".

Circle 135 on card or click "PTEN e-inquiry" on VehicleServicePros.com

VSI N_XGen

#1 in Secure Reprogramming

Vehicle industry expert DG Technologies brings you the **ONLY SECURE** pass-thru device you can trust!

- ✓ Leading J2534 OE Validated Adapter
- ✓ Full OEM Software Compatibility
- ✓ Most Advanced Pass-thru Technology (J2534 v05.00 and 04.04)
- ✓ 4 CAN Channels + CAN FD
- ✓ Advanced Security Capability
- ✓ DG Diagnostics Software
- ✓ SAE J2534-1/-2 Compliant
- ✓ Locksmith/Vehicle Security
- ✓ Award Winning Tech Support!

SHOP NOW

www.dgtech.com/shop
DG TECHNOLOGIES
 Vehicle Network Solutions

United States Postal Service
Statement of Ownership, Management, and Circulation (Requester Publications Only)

1. Publication Title: PROFESSIONAL TOOL & EQUIPMENT NEWS
 2. Publication Number: 012-426
 3. Filing Date: 9/13/2022
 4. Issue of Frequency: February, March, April, May, June, July, August, September, October, December
 5. Number of Issues Published Annually: 10
 6. Annual Subscription Price: Free to Qualified
 7. Complete Mailing Address of Known Office of Publication (Not Printer): Endeavor Business Media, LLC, 1233 Janesville Ave, Fort Atkinson, WI 53538 Contact Person: Debbie Dumke Telephone: 920-563-1763
 8. Complete Mailing Address of Headquarters or General Business Office of Publisher (Not Printer): Endeavor Business Media, LLC, 331 54th Ave N., Nashville, TN 37209
 9. Full Names and Complete Mailing Addresses of Publisher, Editor, and Managing Editor - Publisher: Kyle Hirko, Endeavor Business Media, LLC 1233 Janesville Ave, Fort Atkinson, WI 53538 ; Editor: Brendan Baker, Endeavor Business Media, LLC 1233 Janesville Ave, Fort Atkinson, WI 53538 ; Managing Editor: .
 10. Owner - Full name and complete mailing address: Endeavor Media Holdings I, LLC, 905 Tower Place, Nashville, TN 37205; Endeavor Media Holdings II, LLC, 905 Tower Place, Nashville, TN 37205; Resolute Capital Partners Fund IV, LP, 20 Burton Hills Blvd, Suite 430, Nashville, TN 37215; RCP Endeavor, Inc, 20 Burton Hills Blvd, Suite 430, Nashville, TN 37215; Northbrook Mezzanine Fund II, LP, 312 Walnut Street, Suite 2310, Cincinnati, OH 45202; Invergarity Holdings, LP, 44235 Hillsboro Pike, Nashville, TN 37215; Everside Fund II, LP, 155 East 44th St, Suite 2101 - 10 Grand Central, New York, NY 10017; Everside Endeavor F1 Blocker, LLC, 155 East 44th St, Suite 2101 - 10 Grand Central, New York, NY 10017; Everside Endeavor International Blocker, LLC, 155 East 44th St, Suite 2101 - 10 Grand Central, New York, NY 10017; Everside Founders Fund, LP, 155 East 44th St, Suite 2101 - 10 Grand Central, New York, NY 10017; Suncap Endeavor Blocker, LLC, 155 East 44th St, Suite 2101 - 10 Grand Central, New York, NY 10017;
 11. Known Bondholders, Mortgagees, and Other Security Holders Owning or Holding 1 Percent or More of Total Amount of Bonds, Mortgages or Other Securities: None
 12. Tax Status (For completion by nonprofit organizations authorized to mail at nonprofit rates) (Check one)
 The purpose, function, and nonprofit status of this organization and the exempt status for federal income tax purposes: N/A
 13. Publication Title: PROFESSIONAL TOOL & EQUIPMENT NEWS
 14. Issue Date for Circulation Data: September 2022
 15. Extent and Nature of Circulation

	Average No. Copies Each Issue During Preceding 12 Months	No. Copies of Single Issue Published Nearest to Filing Date
a. Total Number of Copies (Net press run)	101,629	101,116
b. Legitimate Paid and/or Requested Distribution (By Mail and Outside the Mail)		
(1) Outside County Paid/Requested Mail Subscriptions stated on PS Form 3541. (Include direct written request from recipient, telemarketing and Internet requests from recipient, paid subscriptions including nominal rate subscriptions, employer requests, advertiser's proof copies, and exchange copies.)	100,094	100,105
(2) In-County Paid/Requested Mail Subscriptions stated on PS Form 3541. (Include direct written request from recipient, telemarketing and Internet requests from recipient, paid subscriptions including nominal rate subscriptions, employer requests, advertiser's proof copies, and exchange copies.)	0	0
(3) Sales Through Dealers and Carriers, Street Vendors, Counter Sales, and Other Paid or Requested Distribution Outside USPS®	0	0
(4) Requested Copies Distributed by Other Mail Classes Through the USPS (e.g. First-Class Mail®)	0	0
c. Total Paid and/or Requested Distribution (Sum of 15b (1), (2), (3), and (4))	100,094	100,105
d. Nonrequested Distribution (By Mail and Outside the Mail)		
(1) Outside County Nonrequested Copies Stated on PS Form 3541 (include Sample copies, Requests Over 3 years old, Requests induced by a Premium, Bulk Sales and Requests including Association Requests, Names obtained from Business Directories, Lists, and other sources)	745	749
(2) In-County Nonrequested Copies Stated on PS Form 3541 (include Sample copies, Requests Over 3 years old, Requests induced by a Premium, Bulk Sales and Requests including Association Requests, Names obtained from Business Directories, Lists, and other sources)	0	0
(3) Nonrequested Copies Distributed Through the USPS by Other Classes of Mail (e.g. First-Class Mail, Nonrequestor Copies mailed in excess of 10% Limit mailed at Standard Mail® or Package Services Rates)	0	0
(4) Nonrequested Copies Distributed Outside the Mail (Include Pickup Stands, Trade Shows, Showrooms and Other Sources)	600	108
e. Total Nonrequested Distribution (Sum of 15d (1), (2), (3), and (4))	1,345	857
f. Total Distribution (Sum of 15c and 15e)	101,439	100,962
g. Copies not Distributed	190	154
h. Total (Sum of 15f and g)	101,629	101,116
i. Percent Paid and/or Requested Circulation (15c divided by 15f times 100)	98.67%	99.15%
16. Electronic Copy Circulation		
a. Requested and Paid Electronic Copies	-	-
b. Total Requested and Paid Print Copies (Line 15c) + Requested/Paid Electronic Copies (Line 16a)	100,094	100,105
c. Total Requested Copy Distribution (Line 15f) + Requested/Paid Electronic Copies (Line 16a)	101,439	100,962
d. Percent Paid and/or Requested Circulation (Both Print & Electronic Copies) (16b divided by 16c x 100)	98.67%	99.15%

certify that 50% of all my distribution copies (electronic and print) are legitimate requests or paid copies.

17. Publication of Statement of Ownership for a Requester Publication is required and will be printed in the:
 Issue of this publication. Date Oct-22

18. Debbie Dumke, Sr Audience Development Manager 9/13/22

I certify that all information furnished on this form is true and complete. I understand that anyone who furnishes false or misleading information on this form or who omits material or information requested on the form may be subject to criminal sanctions (including fines and imprisonment) and/or civil sanctions (including civil penalties).

TURN YOUR TOOL IDEA INTO MONEY

LISLE CORPORATION CURRENTLY PAYS ROYALTIES TO OVER 120 INDIVIDUALS.

Lisle has been in business for over 110 years and for over 40 years have been working with individuals on an award or royalty basis. If you have an original tool idea which others may need, we have a procedure to evaluate your idea.

Respond now to request an idea disclosure packet.

P.O. Box 89 • Clarinda, IA 51632-0089
 712-542-5101 • Fax 712-542-6591
www.lislecorp.com/about/program

Looking forward to meeting you at **AAPEX**
November 1-3
Booth A2455

ACUSTRIP
 The Diagnostic Detective
www.ACUSTRIP.com



more with square inches as opposed to cubic inches. A lot of [toolboxes] have deeper drawers, and it's kind of wasted space."

When Weinberger puts tools and equipment in his toolbox, he likes to remove any extraneous packaging, like blow-molded cases, and set the tools directly inside the drawers. Without the extra packaging to take up space, he notes it's "a better bang for your buck."

Another customization the shop owner likes are the adjustable shelves in his side cabinets. The shelves span the length of the cabinets and also function as slide-out drawers.

Aside from removing the tools from their cases, Weinberger uses rails and a clip system to keep his sockets organized – a system that enables him to remove the full rail if he needs as well as allows him to easily see if a socket is missing. Additionally, he doesn't like storing the sockets in pull-out drawers. While he knows the drawers can handle plenty of weight, he likes to keep them in the top lid — one of his "idiosyncrasies" as he puts it.

THE START OF IT ALL

Ever since he was a child, Weinberger has been tinkering around with objects and playing with tools. His father was a technician, so he says, "I guess I just have it in my blood."

Fast forward 42 years, and Weinberger owns his own shop. He worked by himself for a long time before finally hiring another tech to lend him a hand.

The eight-bay shop has seven lifts and the tools and equipment to perform complete car care.

"We pretty much do everything but bodywork, and I also do transmission repair – that's kind of my specialty – and of course the towing," Weinberger says.

Looking back on opening his business, Weinberger notes he's dealing with three generations now. He's working on the vehicles of the grandchildren whose grandparents first visited his shop. ❌

Want to see more photos of Weinberger's box? Visit: [VehicleServicePros.com/21278372](https://www.VehicleServicePros.com/21278372)



Want to show off YOUR Big-Time Box? For more information, email Editor@VehicleServicePros.com.

A custom fit

This shop owner was sold on his toolbox when he learned he could customize it to fit his needs.

By Emily Markham, Associate Editor

For shop owner Marc Weinberger, customization played a key role in putting together his current toolbox set-up. Wanting to update from his previous teal, triple bank toolbox, Weinberger looked to his Mac Tools distributor for something a bit bigger, a bit more versatile, and a whole new color.

The new set-up in Marc's Towing and Auto Repair in Kingston, N.Y., consists of two toolboxes Weinberger bolted together (top and bottom) – the MB1900 and MB1910 Macsimizers – along with two side lockers, one on each end. The

OWNER

Marc Weinberger

Shop: Marc's Towing & Auto Repair

Location: Kingston, N.Y

whole set-up is bright yellow and reaches 73" tall, 29.5" deep, and 19' 7" long.

MAKING IT HIS OWN

Back in 2005, when Weinberger was deciding on this new toolbox, he really took the time to customize it to fit his needs. His number one customization was a lot of drawers.

"I added more drawers, and it wasn't any more money," Weinberger notes. "I went

TRIPLE THREAT

THAT GETS IN YOUR GRILLE

NEW! MAXISYS MS909CV



3-IN-1 HEAVY DUTY REPAIR



INTELLIGENT DIAGNOSTICS

Covers Over 80 Makes & Models

Lightning-Fast All System AutoSCAN

Module Topology on Select Vehicles

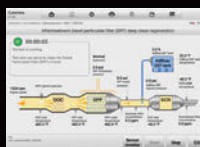

ADAS CALIBRATION

- + Complete ADAS Calibration* for Class 3-5 Vehicles
- + **NEW** Dynamic ADAS Calibration for Class 6-8 Vehicles

*Additional Purchases Required



BATTERY ANALYSIS

- + Generate HD Battery Test & Health Report
- + Current Clamp & Multimeter Included



MS906CV
TRIAGE SERVICE



MS908CV
ADVANCED DIAGNOSTICS

LAUNCH TPMS

PROGRAMMING IN MOTION



315 MHZ
433 MHZ

LTR SENSOR



30TH
SINCE 1992
LAUNCH



TSAP-3

MANUAL RELEARNS
20+ SENSORS
RETROFIT KITS
SENSOR DATA

OBDM RELEARNS
PART# LOOKUP TPMS
INSTALL & SERVICE TPMS
FULL-COLOR DISPLAY
SENSOR SUPPORT
IN-TIME UPDATES

**WI-FI UPDATE
DUAL FREQUENCY**



READING & PROGRAMMING & ACTIVATION



MOTORCYCLE AND DUALY VEHICLES



Circle 137 on card or click "PTEN e-inquiry" on VehicleServicePros.com

www.launchtechusa.com

1-877-528-6249

@LaunchTechUSA

**LAUNCH
TECH USA**
CREATE • CHANGE