

# PTEN

PROFESSIONAL TOOL & EQUIPMENT NEWS

\$15.00 • September 2022  
Volume 33, Number 8

ENDEAVOR  
BUSINESS MEDIA

2022  
GREAT PRIZE  
★ GIVEAWAY ★  
✂

PAGE 12



**TOOL BRIEFING**  
ENGINE REPAIR  
PAGE 26

**CATEGORY SPOTLIGHT**  
HAND TOOLS &  
SPECIALTY TOOLS  
PAGE 42

## ERGOCHAIR BY BENDPAK

DETAILS ON THE COVER PRODUCTS  
AND OTHER NEW TOOLS **PAGE 10**



▲ Has a 1,763 lb static load capacity



▲ Able to test seven different 12V relays



▲ Safely transports disabled vehicles



**EZRED**

Introducing a whole new concept:

# FLEXIBLE MAGNETIC ORGANIZATION



## WRENCH HOLDERS

FWR12-R

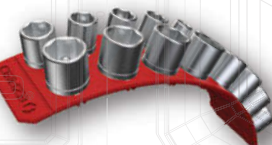

## SOCKET HOLDER

FSR18-R

## SPRAY CAN HOLDER

EZCH-R



## PRY BAR HOLDERS



PBH4-R



PBH1-R



**TOOL MAT**  
MAGMAT-R



# Stay Organized. Anywhere.

800-522-7947

ezred.com

YouTube

Circle 1 on card or click "PTEN e-inquiry" on [VehicleServicePros.com](http://VehicleServicePros.com)

Creating Innovative Products



**EZRED**

# THINKCAR

## WIN WITH TECHNOLOGY!

- 1 Composite body panels
- 2 Single lug wheels
- 3 Independent rear suspension
- 4 Larger brakes
- 5 Rack & pinion steering
- 6 Transaxle configuration
- 7 Sealed underbody with underwing & rear diffuser
- 8 Louvered hood

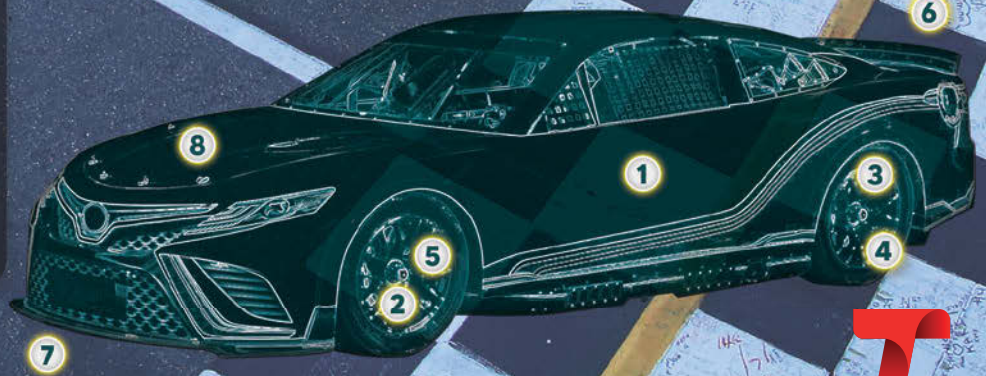

## Just like NexGen cars, our Platinum Series tools feature the most advanced technology!

- Advanced operating system based on the latest & fastest Android version
- Unbeatable vehicle coverage with special feature access
- High-performance telecommunication based chipsets
- Solid state memory for greater access speed & shock protection

**We invest over \$200 million annually in research and development to ensure our tools provide outstanding performance, are easy of use and deliver unsurpassed coverage!**

## Dare to compare side by side to your current scan tool!

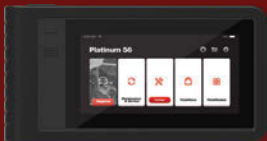

PLATINUM S6



PLATINUM HD



PLATINUM S20



PLATINUM S10 PRO

US Tech Support Ph: 833-692-2766 | Business Hours Mon - Fri 8am - 5pm PST  
Circle 2 on card or click "PTEN e-inquiry" on [VehicleServicePros.com](http://VehicleServicePros.com)

# CONTENTS

Published by Endeavor Business Media, LLC

**ENDEAVOR** BUSINESS MEDIA 30 Burton Hills Blvd, Ste 185  
Nashville, TN 37215  
800-547-7377

Printed in the U.S. Volume 33, Number 8; September 2022

**EXECUTIVE VICE PRESIDENT – TRANSPORTATION**  
Reggie Lawrence RLawrence@EndeavorB2B.com

**VP/GROUP PUBLISHER, ENDEAVOR VEHICLE REPAIR GROUP** Kylie Hirko  
630-253-4034 Kylie@VehicleServicePros.com

**EDITORIAL DIRECTOR** Amanda Silliker  
ASilliker@EndeavorB2B.com

**ASSOCIATE EDITOR** Emily Markham  
920-234-6359 EMarkham@EndeavorB2B.com

**ASSOCIATE EDITOR** Kayla Oschmann  
920-563-1764 KOschmann@EndeavorB2B.com

**TECHNICAL EDITOR** Brandon Steckler

**ASSOCIATE SALES DIRECTOR** Mattie Gorman-Greuel  
920-563-1636 MGorman@EndeavorB2B.com

**DIRECTOR OF BUSINESS DEVELOPMENT** Cortni Jones  
920-568-8391 CJones@EndeavorB2B.com

**MULTIMEDIA ACCOUNT EXECUTIVE** Diane Braden  
920-568-8364 DBraden@EndeavorB2B.com

**MULTIMEDIA ACCOUNT EXECUTIVE** Lisa Mend  
949-259-5654 LMend@EndeavorB2B.com

**MULTIMEDIA ACCOUNT EXECUTIVE** Michael Parra  
925-307-8779 MParra@EndeavorB2B.com

**MULTIMEDIA ACCOUNT EXECUTIVE** Paul Ropski  
815-255-4118 PRopski@EndeavorB2B.com

**INSIDE SALES** James Hwang  
801-823-1704 JHwang@EndeavorB2B.com

**PRODUCTION MANAGER** Jane Pothlanski  
224-324-8507 JPothlanski@EndeavorB2B.com

**AD SERVICES MANAGER** Carmen Seeber  
920-568-8373 CSeeber@EndeavorB2B.com

**ART DIRECTOR** Tim Schafer

**LIST RENTAL REP** Michael Costantino  
402-836-6266 Michael.Costantino@infogroup.com

**LIST RENTAL REP** Kevin Collopy  
402-836-6265 Kevin.Collopy@infogroup.com

**AUDIENCE DEVELOPMENT MANAGER** Debbie Dumke

**ENDEAVOR BUSINESS MEDIA, LLC**

CEO – Chris Ferrell

President – June Griffin

CFO – Mark Zadell

COO – Patrick Rains

Chief Administrative and Legal Officer – Tracy Kane

EVP/Group Publisher - Transportation – Reggie Lawrence

EVP Marketing Solutions & Data – Jacquie Niemiec

Subscription Customer Service

877-382-9187; 847-559-759

Circ.ProfDistmag@omeda.com

PO Box 3257 • Northbrook IL 60065-3257

Article reprints reprints@endeavorb2b.com



*Professional Tool & Equipment News* (USPS 012-426, ISSN 1081-4485 print; ISSN 2150-2072) is published ten times a year in February, March, April, May, June, July, August, September, October, and December by Endeavor Business Media, LLC, 1233 Janesville Avenue, Fort Atkinson, WI 53538. Periodicals postage paid at Fort Atkinson, WI 53538 and additional mailing offices. POSTMASTER: Send address changes to *Professional Tool & Equipment News*, PO Box 3257, Northbrook, IL 60065-3257. Canada Post PM40612608. Return undeliverable Canadian addresses to: *Professional Tool & Equipment News*, PO Box 25542, London, ON N6C 6B2.

Subscriptions: Individual subscriptions are available without charge in the U.S. to qualified subscribers. Publisher reserves the right to reject non-qualified subscriptions. Subscription prices: U.S. \$50 per year, \$93 two year; Canada/Mexico \$72 per year, \$131 two year; All other countries \$105 per year, \$195 two year. All subscriptions payable in U.S. funds, drawn on U.S. bank. Canadian GST#R42773848. Back issue \$10 prepaid, if available. Printed in the USA. Copyright 2022 Endeavor Business Media, LLC.

All rights reserved. No part of this publication may be reproduced or transmitted in any form or by any means, electronic or mechanical, including photocopy, recordings or any information storage or retrieval system, without permission from the publisher.

Endeavor Business Media, LLC does not assume and hereby disclaims any liability to any person or company for any loss or damage caused by errors or omissions in the material herein, regardless of whether such errors result from negligence, accident or any other cause whatsoever. The views and opinions in the articles herein are not to be taken as official expressions of the publishers, unless so stated. The publishers do not warrant, either expressly or by implication, the factual accuracy of the articles herein, nor do they warrant any views or opinions offered by the authors of said articles.



34

## ON OUR COVER

**Ergochair by BendPak**

Details on page 10.



42



## EXCLUSIVE

### 40 INNOVATION AWARDS

Learn more about one of this year's most innovative new products

## PRODUCTS

### 10 NEW PRODUCTS

Check out offering from Power Probe, Vessel, Ingersoll Rand, and more.

### 34 TOOL REVIEWS

Our review panel tests out six different tools and gives their feedback.

### 42 CATEGORY SPOTLIGHT

Hand Tools & Specialty Tools

## COLUMNS

### 8 EDITOR'S NOTE

Can you afford to not tackle ADAS?

### 20 DIAGNOSTIC TECH

Scott Brown discusses some of the challenges with repairing ADAS.

### 26 TOOL BRIEFING

Ross Colket talks diagnosing fuel systems and knowing what tool to use to get the job done.

### 58 BIG-TIME BOXES

Jacob Eldridge, Don's Auto Center in Corsicana, Texas



58

AUTEL MAXITPMS

ITS600

# ITSTPMS+MORE

INTELLIGENT TIRE SERVICE



## TBE200

### LASER MEASUREMENT

- Tire Tread Depth Measurement
- Brake Disk Wear Measurement
- No Need To Remove Wheel During Measurement
- 0.1mm Laser Accuracy

## 1-SENSOR

### DUAL FREQUENCY

- Programmable Universal TPMS
- 99% Vehicle Coverage
- Exclusive Press Release Button
- Interchangeable Valve Stems

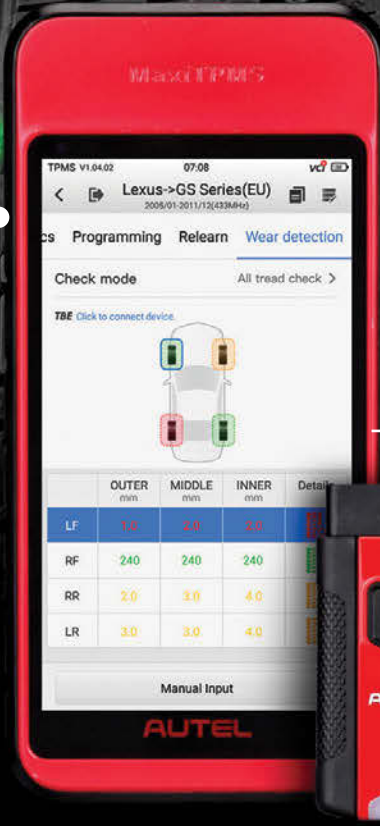

TPMS V1.04.02 07:08 vdi

Lexus->GS Series(EU)  
2008/01/2011/12(433864)

cs Programming Relearn Wear detection

Check mode All tread check >

TBE Click to connect device:

	OUTER (mm)	MIDDLE (mm)	INNER (mm)	Detail
LF	1.2	2.0	3.0	2.0
RF	2.40	2.40	2.40	2.40
RR	2.0	3.0	4.0	2.0
LR	3.0	3.0	4.0	2.0

Manual Input

AUTEL



COMPLETE TPMS SERVICE  
4 SENSOR PROGRAMMING OPTIONS

## ITS600 DIAGNOSTICS & SERVICE

- 5.5" Touchscreen Tablet with Android 9.0 OS
- Optical Scanner Identifies VIN / MMY
- Four Service Resets OLS, BMS, SAS and EPB
- Read & Erase All System Codes
- FREE Wi-Fi Software Updates for Life Of Tool

POWERED BY  
**AUTEL**  
DIAGNOSTICS

Circle 3 on card or click "PTEN e-inquiry" on VehicleServicePros.com

SUPPORT: 1.855.288.3587  
 EMAIL: USSUPPORT@AUTEL.COM | WEB: AUTEL.COM  
 VIEW MARKETING MATERIAL: ISSUU.COM/AUTEL2  
 FOLLOW US @AUTELTOOLS



# AUTEL

# NOW ONLINE AT **VEHICLESERVICEPROS**.com

## VIDEO



**PTEN** Tool Review: Tanner Brandt, owner of the Auto Diag Clinic in Greenville, S.C., reviews CTEK's PRO25S 25A Battery Charger and Power Supply, a tool that combines power and advanced technology with safety, portability, and flexibility to work with any 12V vehicle battery, including lithium.

**VehicleServicePros.com/21270142**

## NEW PRODUCTS



Thinking of adding tire service to your shop's repertoire but unsure of where to even start when it comes to all the tools and equipment you'll need? Here's a list of recently released products to consider.

**VehicleServicePros.com/21276961**

## TECHNICIAN PROFILE

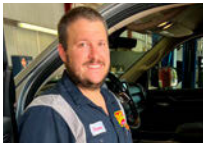

Third-generation automotive tech Chase Zembower was one of the top 10 runners-up for *PTEN*'s Best Young Tech Award in 2021. "You have got to stay on top of all the latest trainings and continue to obtain the appropriate tools and equipment or you will find yourself at a severe disadvantage in this industry," he notes.

**VehicleServicePros.com/21276683**

## TRAINING



The complexity of today's vehicles means technicians are flooded with additional data when diagnosing vehicle faults. Here are ways and tools to help diagnose these faults.

**VehicleServicePros.com/21274485**

## PODCASTS

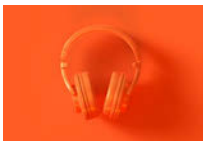

Slide on your headphones and catch up on what's new with this month's podcast playlist, featuring podcasts covering hybrids and EVs, key programming, the new ADAS ASE certification, and more.

**VehicleServicePros.com/21276221**

## FEATURED PRODUCTS



### Milwaukee Tool

M12 Heated Hoodie

**VehicleServicePros.com/21275414**



### OTC

Pitman Arm Puller, No. 5857

**VehicleServicePros.com/21275479**



### Hessaire Products

MC61V Mobile Evaporative Cooler

**VehicleServicePros.com/21275314**



### CTA

Ford Crankshaft Rear Seal Installer - PowerStroke, No. 8229

**VehicleServicePros.com/21277265**

# ACCESS GRANTED



## X-431 IMMO PRO



**DBSCAR VII**  
BUILT-IN CANFD



**X-PROG 3**



### Highlights



Anti-theft Type Identification



Remote Control Matching



Key Chip Read & Write



Anti-theft Password Reading



Anti-theft Component Replacement



Bi-directional control

### Configuration

- 8" Touch Screen Android 10.0
- 4GB Memory, 64GB Storage
- Rear 8MP Camera
- 2.4GHz/5GHz Wi-Fi Connection

### Optional Cable:



- Anti-theft programmer MCU3 adapter board kit



- Anti-theft programmer to simulate the key

Circle 4 on card or click "PTEN e-inquiry" on VehicleServicePros.com



# Can you afford to not tackle ADAS?

If you're burying your head in the sand with ADAS, how does this affect your long-term plans?

By **Amanda Silliker**, Editorial Director  
[ASilliker@EndeavorB2B.com](mailto:ASilliker@EndeavorB2B.com)

**The more I learn about ADAS, the more I am convinced every single automotive repair shop should be handling these repairs. I know many of you are farming out these repairs to mobile services or dealerships, but in the not too distant future, every repair you do is likely to have an ADAS component, so why not just rip off the Band-Aid and tackle ADAS now?**

In his article on page 20, Scott Brown explains how any changes to the body, repair, paint, etc. can negatively affect the operation of a vehicle's radar sensors — critical components of ADAS. The sensors are extremely delicate and need to be replaced if the vehicle has been in a collision, and they must be properly calibrated. He also shares a case study where a customer's lane keeping system was not working properly. Brown had to diagnose the issue and he was able to resolve the problem for his customer. If this scenario showed up in your shop, wouldn't it feel good to be able to fix the problem yourself for your customer?

Plus, it's an additional revenue stream that cannot be ignored.

Brown points out that the skills you already have for electrical or engine performance will serve you well when addressing ADAS complaints or service requirements. If interested, there are many training opportunities out there that can get you ready to perform these repairs. Brown even notes you might already have the tools you need to address most diagnostic and service requirements. Yes, you may need to reconfigure your shop to ensure more space for this type of work, but run some numbers, and you will likely find it will be worth it in the end.

At the 2022 ETI ToolTech event, the results of a recent research project by AASA were revealed. "ADAS Aftermarket Ecosystem 2030: The Coming Wave of Aftermarket Opportunity" found the following:

- One million vehicles required ADAS service in an aftermarket shop in 2021.
- Ninety percent of ADAS work coming into mechanical shops is outsourced.
- ADAS parts and services will experience 17 percent compound annual growth rate through 2030.

"I really see ADAS as J2534 on steroids," said Jim Fish, managing partner for New Hammer Ventures who conducted the research. "J2534 was a learning curve. There were many of the same problems that ADAS faces in the field."

On a personal note, this is my last issue as editorial director of PTEN. I have decided to take on a new challenge at a non-profit safety association, so while you are out there getting the job done as fast as possible, remember to do it safely, too! ❌

## **PTEN EDITORIAL ADVISORY BOARD**

### **TECHNICIANS**

- ERIC MOORE**,  
DeMary Trucks, Columbus, OH
- LOU FORT**,  
K.A.R.S. Inc., Huntingburg, IN

### **SHOP OWNERS**

- KIM AUERHEIMER**,  
Cool Springs Automotive, Brentwood, TN
- TANNER BRANDT**,  
Autodiag Clinic, Welford, SC
- PHIL FOURNIER**,  
Phil's Auto Clinic, Hemet, CA
- JD GOAD**,  
Goad's Body Shop, Lexington, VA
- EDWIN HAZZARD**,  
Southeast Mobile Tech, Goose Creek, SC
- PETE RUDLOFF**,  
Pete's Garage Inc., Newark, DE
- MICHELLE TANSEY**,  
Dubclinic, Santa Clara, CA

### **EQUIPMENT MANUFACTURERS**

- KIMBERLY COTTLE**  
Associated Equipment
- JIM O'HARA**,  
Clare Automotive





# RAISING THE

# AP SERIES™

# STANDARDS OF EXCELLENCE

*NEW 360-Degree Automatic Swing Arm Restraint System  
Provides the Ultimate In Safety and Vehicle Fall Protection*



BendPak Model  
**10AP**  
Two-Post Lift



Certified to meet the  
standards of ANSI/ALI  
ALCTV: 2017

## Bi-Metric Swing Arms

Our 10AP Series offers the convenience of wide or narrow installation wrapped up into one configurable package. This durable, safe, and reliable car lift features an expandable top beam and BI-METRIC™ arms to suit virtually every vehicle lifting requirement – symmetric or asymmetric. The 2-in-1 design gives operators the option of loading vehicles either symmetrically (centerline of vehicle at column) or asymmetrically (centerline of vehicle behind column). The simple, yet highly sophisticated is sure to keep operating costs low and productivity high. Check out the full line of 10AP lift series at [bendpak.com](http://bendpak.com) or call us at **1-800-253-2363**.

1-800-253-2363 • [BENDPAK.COM](http://BENDPAK.COM)

©2022 BendPak Inc. All rights reserved.

**BP BendPak®**

Circle 5 on card or click "PTEN e-inquiry" on [VehicleServicePros.com](http://VehicleServicePros.com)

# FEATURED NEW PRODUCTS



## AVAILABLE IN FIVE, SEVEN, AND EIGHT DRAWER CONFIGURATIONS

The **RSC24 Mobile Roller Cab** from **Beta Tools** features a reinforced ABS worktop designed with eight holes for screwdrivers and is able to support top boxes. The Beta RSC24 evolved from the C24S toolbox, bringing racing character and high performance to the shop. It offers removable drawers, protective rubber mats, two swivel and two fixed casters, and a front centralized safety lock. Additionally, it has a 1,763 lb static load capacity and all drawers roll on ball-bearing slides. Available in different color combinations and in five, seven, and eight drawer configurations. Optional accessories include: perforated tool panel, computer bracket, document file holder, side mount folding shelf, paper roll holder, and a wooden worktop.

Circle 6 on card or click "PTEN e-inquiry" on [VehicleServicePros.com](http://VehicleServicePros.com)

## ABLE TO TEST SEVEN DIFFERENT 12V RELAYS

The **Electronic Specialties Super Relay Buddy**, No. 194, is designed to provide an indication of the general health and functioning of the most common 4/5 pin 12V relays. It cycles the relay several times while loading the switch contacts to detect any excessive resistance. The tool incorporates a full 7A load into the automated test sequence and is able to test seven different 12V relays. In addition to displaying green for good and red for fail, the Super Relay Buddy has a third test result, yellow for caution. The yellow/caution result is displayed when the voltage drop through the tested relay is significant, but still within operating range of the relay.



Circle 7 on card or click "PTEN e-inquiry" on [VehicleServicePros.com](http://VehicleServicePros.com)



## SAFELY TRANSPORTS DISABLED VEHICLES

The **Body Buggy Chassis Roller** from **Dent Fix Equipment** is designed to quickly and safely transport disabled vehicles, allowing shops to easily roll the vehicle onto a frame rack, into a paint booth, or out of the way when waiting on parts, inspections, or other delays. After a simple five minute installation, the unit essentially becomes part of the vehicle, negating the need to employ any unstable or dangerous lift points. The device can be installed on the front or rear of most any vehicle using the cradle or sub-frame mounting points and hardware. Available in 4' and 5' sizes.

Circle 8 on card or click "PTEN e-inquiry" on [VehicleServicePros.com](http://VehicleServicePros.com)



FOR MORE INFORMATION ON THESE PRODUCTS, CLICK ON "PTEN E-INQUIRY" at [VehicleServicePros.com](http://VehicleServicePros.com) OR CIRCLE THE NUMBER ON THE CARD.

**K**icking off the New Products section each month, our Featured New Products page includes brand new products showcased on the cover that are available to the automotive market.



## MORE ERGONOMIC REPAIRS

The patent-pending **Ergochair** adjustable-height rolling work seat from **BendPak** is designed to make performing awkward work tasks in the shop more ergonomic, reducing stress and strain on technicians' bodies to deliver improved safety, greater productivity, and reduced injuries. Ergochair works as both a chair and a creeper. It features an adjustable seat height and backrest that adjusts up and down, as well as forward and back. Its four casters ensure it moves smoothly in all positions.

Circle 9 on card or click "PTEN e-inquiry" on [VehicleServicePros.com](http://VehicleServicePros.com)

SPONSORED BY BENDPAK



**ABILITY TO TRACK THE TRACTOR AND TRAILER AS SEPARATE ASSETS**

The **Hunter Engineering WinAlign 17.1 Software Update** provides two benefits for Hunter Quick Check Drive and Quick Check Commercial unmanned inspection system customers. First, it bridges the gap between passenger vehicle and heavy duty inspection systems by measuring those trucks too heavy or wide for the passenger tread system, but not tall enough for the full HD system. The new configuration allows for medium duty vehicles, such as bucket trucks, to be accommodated on Hunter's Quick Check Drive unmanned inspection system. Secondly, its dual license plate capture gives fleet customers the ability to track the tractor and trailer as separate assets.

**Circle 10 on card or click "PTEN e-inquiry" on VehicleServicePros.com**



**HEAT-TREATED FOR STRENGTH AND DURABILITY**

The **ATD Tools 4-pc 1/2" Drive Impact Extension Set**, No. ATD-4864, has been heat-treated for strength and durability. Manufactured using quality chrome-molybdenum alloy steel, the set meets or exceeds ANSI specifications. The 4-pc set includes a 3", 6", 7", and 10" impact extension.

**Circle 13 on card or click "PTEN e-inquiry" on VehicleServicePros.com**



**MAXIMUM LIFTING HEIGHT OF 80"**

The **Dannmar D2-12C Symmetric Heavy Duty Two-Post Lift** is a closed-top model which allows technicians to roll floor jacks, toolboxes, and other equipment underneath the elevated vehicle without having to travel over and through a floor-mounted hydraulic line panel. The lift has a 12,000 lb lifting capacity, an oversized 53" tall carriage for strength, triple-telescoping arms to reach a wide range of manufacturer-recommended lifting points, and an extended-height top beam to provide the clearance work trucks need. The D2-12C has a rated load capacity of 12,000 lbs. and a maximum lifting height of 80". Its adjustable top beam can accommodate wide or narrow installations.

**Circle 11 on card or click "PTEN e-inquiry" on VehicleServicePros.com**



**ATTACHES TO ANY POWER-DRIVEN TOOL**

The **Ken-Tool Rust Rhino Hub Cleaning Tool**, No. 30267, attaches to any power-driven tool (pneumatic, electric, or battery). It's capable of accepting a 1/2" square drive and has a maximum rotation of 4,000 rpm. The tool is designed to quickly clean the lug stud and mating surfaces of truck wheel components, ensuring proper torque can be applied and proper clamping force is achieved. The kit includes one additional Rust Rhino Cleaning Head and one extra inner cleaning brush attachment.

**Circle 14 on card or click "PTEN e-inquiry" on VehicleServicePros.com**



**AVAILABLE IN FOUR SIZES**

The **ProMAXX PlierPull Locking Plier Adapters** are designed to produce greater pulling power thanks to their quick slide hammer connectivity. They're ideal for repairs where a high level of force is needed, such as for popping out cotter pins, pulling bushings, seals, and other applications. The adapters are available in four sizes (3/8", 5/8", 5/16", and 7/16") to easily attach to the most common varieties of locking pliers and slide hammers. The adapters are lathe-turned and knurled from hardened steel and black oxide coated to protect against corrosion and wear. Made in the U.S.A.

**Circle 12 on card or click "PTEN e-inquiry" on VehicleServicePros.com**



**COMPATIBLE WITH ALL EV AND HYBRID PLUG-IN VEHICLES**

The **Autel MaxiCharger AC Wallbox Commercial**, No. MCC50AHI, is a 240V-50A Level 2 charger compatible with all EV and hybrid plug-in vehicles. It features a contemporary design in silver, a touch-screen LCD, and is designed to be installed indoors or outdoors. The unit offers adjustable charging up to 50A and features a 25' long universal (J1772) charging cable and hardwire installation. Wi-Fi, Bluetooth, 4G, and ethernet options available.

**Circle 15 on card or click "PTEN e-inquiry" on VehicleServicePros.com**

**VEHICLE  
SERVICE  
PROS**.com  
PRESENTS

# 2022 GREAT PRIZE GIVEAWAY ★



SEPT. 1 - OCT. 31, 2022\*

**WE'RE  
GIVING  
AWAY**

# \$25,000+

**IN PRIZES.**

ENTER EVERY DAY FOR MORE CHANCES TO WIN AT  
**VEHICLESERVICEPROS.COM/GPG!**

VehicleServicePros.com, the official website of *PTEN*, *Motor Age*, and *ABRN* in partnership with the vendors that supply the vehicle service market with the latest products to improve your business, are pleased to introduce the ninth annual Great Prize Giveaway! Who doesn't love to win something? Better yet, you don't have to pay to play!

Vendors have partnered with VehicleServicePros.com to offer you a chance to win prizes. Vote for up to five products each day, increasing your chances for those particular prizes. Visit [VehicleServicePros.com/gpg](https://www.vehicleservicepros.com/gpg) to view all prizes and enter to win Sept. 1 – Oct. 31, 2022. Winners will be notified by November 15th. *Good luck!*

- HOW TO ENTER:**
- Visit [VehicleServicePros.com/gpg](https://www.vehicleservicepros.com/gpg) to view all prize details and enter to win.
  - To enter, check boxes on the entry page for your top five products.
  - Be sure to stop back daily to improve your chances of winning.

BROUGHT TO YOU BY:

**PTEN**  
PROFESSIONAL TOOL & EQUIPMENT NEWS

**MOTOR AGE**

**ABRN**  
AUTO BODY REPAIR NETWORK

**VEHICLESERVICEPROS**.com

PROMOTION



**AirCat Tool Giveaway**  
Prize value: \$500



**OEMTOOLS Oil Service Prize Pack**  
Prize value: \$649.96

★ Enter at [VehicleServicePros.com/GPG](http://VehicleServicePros.com/GPG)



**XTools USA Nitro LT & Auto Keys**  
Prize value: \$2,250



**ToolAid Electrical Diagnostic and Repair Pack**  
Prize value: \$615



**Autel ITS600 Sensor Kit**  
Prize value: \$965



**Induction Innovations Mini-Ductor Venom HP + Coil Kit**  
Prize value: \$736.50



**Oasis Scientific ME-610i Borescope**  
Prize value: \$900



**StreamLight 2022 Worklights Prize**  
Prize value: \$750



**BOSCH SMT 500 Smoke Machine Leak Tester with built-in Air Compressor**  
Prize value: \$1,972



**KTOOL Deluxe Mechanics Tool Set**  
Prize value: \$3,600



**Opus IVS Mongoose-Plus J2534 Device**  
Prize value: \$495



**TEXA Nano S, IDC5 Car and Tablet**  
Prize value: \$4,495



**COAST Bright Light Bundle**  
Prize value: \$715



**Lang Tools Made in USA Specialty Tools**  
Prize value: \$550



**OTC Ball Joint Connected Adapter Professional Kit**  
Prize value: \$2,140

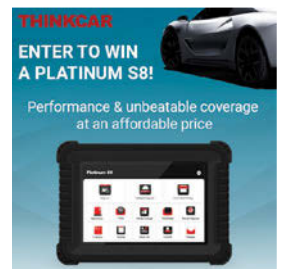

**ThinkCar Platinum S8**  
Prize value: \$1,249



**Gray 7-THF Vehicle Support Stands**  
Prize value: \$500



**Launch Millennium MAX Scan Tool**  
Prize value: \$799



**ProMAXX Ford 3.5 EcoBoost EMR**  
Prize value: \$613.25

**Contest rules**

Entrants in the Great Prize Giveaway promotion must be a professional owner, manager or technician responsible for repairing and/or maintaining vehicles. Each entrant must be an employee of a fleet facility or vehicle service center as of August 31, 2021. Each entrant can register for up to five (5) products per day. Product registration entries may be submitted from 12:00 a.m. C.S.T. on September 1, 2022 through 11:59 p.m. C.S.T. on October 31, 2022 ("Entry Period") at [VehicleServicePros.com](http://VehicleServicePros.com). No other method of entry will be accepted. Endeavor Business Media, LLC's computer is the official time keeping device. Winners will be selected at random from all eligible entries received during the Entry Period. Odds of winning depend on the actual number of entries received for each product during the Entry Period. There is no limit on the number of products an entrant may win. Employees of Endeavor, Inc. or any Product Sponsor(s), their immediate family members (spouses and siblings, children and parents and their spouses, regardless of where they live), and members of their households (whether related or not) are not eligible to participate. Endeavor Business Media, LLC reserves the right to disqualify any entry. No purchase or subscription is necessary to win. Prize values may be rounded to the nearest dollar, or \$100. Purchase of or subscription to any Endeavor Business Media, LLC-related publications does not increase chances of winning. The Great Prize Giveaway promotion shall be governed exclusively by the laws of the State of Tennessee. Void in Florida and where prohibited or restricted by law. The full list of rules and regulations can be found at [VehicleServicePros.com/gpg](http://VehicleServicePros.com/gpg).

## NEW PRODUCTS



### ADJUSTABLE IN FIVE STAGES

The **Tire Mechanics Resource Air Operated Elevating Heavy Duty Tire Spreader** uses shop air to easily lift and repair large truck tires. The pneumatic lifting table can raise the tire to the ideal inspection and working height. By adjusting the clamp arms and rollers as well as the pneumatic lift table allows the operator to repair all tire sizes (passenger, small and large truck) to perform tire inspection, cutting, buffing, cleaning, patching, and more. The tire spreader is adjustable in five stages with a maximum enlargement at 13.8". It has a maximum elevating height of 26", and features an adjustable light, a movable tool rack, and adjustable clamping arms and tire rollers.

**Circle 16 on card or click "PTEN e-inquiry" on VehicleServicePros.com**



### INCLUDES SIZES 6MM TO 21MM

The **CTA 17-pc Deep Metric Socket Set**, No. 1189, includes sizes 6mm to 21mm. With a 120mm length and depth, the sockets provide access to recessed areas with extra long bolts found on valve cover bolts (7mm), diesel glow plugs (10mm, 12mm, 17mm), Benz C-Class (W204) rear bumper covers (10mm, 12mm), BMW N54 twin-turbo valve cover bolts (12mm), BMW E90/92 lug nuts (17mm), BMW spark plugs (14mm), BMW E90/92 clutch bleeder valve (11mm), and Ford 7.3L glow plugs (10mm), and more. Sockets 8mm to 18mm include a 3/8" square drive and sockets 19mm to 21mm include a 1/2" square drive. The set includes two drive adapters: 1/2" to 3/8" and 3/8" to 1/4".

**Circle 19 on card or click "PTEN e-inquiry" on VehicleServicePros.com**



### FEATURES A 360-DEGREE, FULLY ADJUSTABLE SIDE HANDLE

The **Ingersoll Rand 2955 Series 1-1/2" Impact Wrench** is designed to deliver heavy duty power, durability, and productivity. The 2955 Impact Wrench produces 4,500 ft-lbs of maximum reverse torque powered by a finely-tuned, warm-forged twin-hammer impact mechanism. Steel hammer case with aluminum motor housing and handle provide durability, while steel endplates resist wear. The auxiliary handle allows the tool to be configured for the operator or application. The handle is fully adjustable to any orientation around the hammer case body, allowing the tool to reach into confined bolt locations or fit to the most user-friendly position, reducing operator fatigue.

**Circle 17 on card or click "PTEN e-inquiry" on VehicleServicePros.com**



### AVAILABLE IN SHORT AND STANDARD DESIGNS

The **Ascot Supply 20-Ton Air/Hydraulic Bottle Jacks** feature a thick base to provide ideal support and stability in severe conditions. The quick connect feature on the air valve allows for an easy disconnect and connection of air hose. The bottle jacks come with compact storage and a 9-3/8" handle. Available in both a short and standard design. The short style has a lift range from 7" to 12-5/8", while the standard style has a lift range from 10-1/8" to 19-7/8". Includes a one-year limited warranty.

**Circle 20 on card or click "PTEN e-inquiry" on VehicleServicePros.com**



FOR MORE INFORMATION ON THESE PRODUCTS, CLICK ON "PTEN E-INQUIRY" at [VehicleServicePros.com](http://VehicleServicePros.com) OR CIRCLE THE NUMBER ON THE CARD.

### CAN MEASURE AND INDICATE THE EXACT VOLTAGE

The **Power Probe Volt Tester**, No. VT750LCD, is a compact automatic voltage tester up to 750V. It can measure and indicate the exact voltage (AC/DC), phase indication, and phase rotation, and continuity, RCD, and resistance via an LCD. Features 2,000 count digital display, 2,000 ohms resistance range, a 1,000 Hz frequency counter, an integrated single pole test for phase detection, and IP65 for outdoor use. The operation time is 30 seconds, and the recovery time is 240 seconds.

**Circle 18 on card or click "PTEN e-inquiry" on VehicleServicePros.com**



Watch this product in action here: [VehicleServicePros.com/21270885](http://VehicleServicePros.com/21270885)



### INTEGRATED GUIDE PINS WITH CLEANING GROOVES

The **Mueller-Kueps Sensor Tap Kit**, No. 506 021, is designed to professionally restore the NOx sensor hole thread without damaging the exhaust system. The tools are for sensors sizes M20x1.5 and M22x1.5. Coarse carbon deposits are removed by the guide pin with cleaning grooves. Measuring just 27mm in length, the extra short tools can be used in extremely tight spaces. Each tool features hard material coating, six cutting edges for ideal centering, and integrated guide pins for recutting dirty holding threads, especially for NOx and particle filter sensors on exhaust systems. Made in Germany.

**Circle 21 on card or click "PTEN e-inquiry" on VehicleServicePros.com**

# HARNESS THE POWER

INTRODUCING THE MOST  
INTELLIGENT YET AFFORDABLE  
DIAGNOSTIC TOOLS EVER UNLEASHED!



## OTOFIX IM1

- KEY PROGRAMMER
- DIAGNOSTICS TABLET
- SERVICE RESETS

## OTOFIX D1

- BIDIRECTIONAL FUNCTIONALITY
- DIAGNOSTICS TABLET
- SERVICE RESETS

## OTOFIX BT1

- BATTERY TESTING
- ELECTRICAL SYSTEM ANALYSIS
- DIAGNOSTICS & SERVICE RESETS

# OTOFIX™

WWW.OTOFIXTECH.US ○ @OTOFIXTOOLS



## NEW PRODUCTS

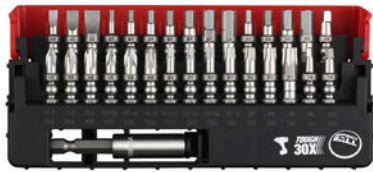

### COMES IN A SLIDE CASE

The **Vessel Tool IMPACT BALL Torsion Bit 30+1-pc Set**, No. IB31P02U, comes in a slide case. The product includes +1, +2, +3, SL4, SL6, SL8, SQ1, SQ2, SQ3, T10, T15, T20, T25, T27, T30, T40, PZ1, PZ2, PZ3, H3, H4, H5, H6, H3/32, H7/64, H1/8, H9/64, H3/16, H7/32, H1/4, and 1/4" hex bit holders with C-ring retainers. The set also features magnetized tips, high wear-resistance, durable bits made from VoHA material, and the highest hardness (62 HRC) created by in-house optimum heat treatment.

Circle 23 on card or click "PTEN e-inquiry" on [VehicleServicePros.com](http://VehicleServicePros.com)

**CUSTOMER REVIEW:**  
"This is a high-quality set, with a nice sturdy feeling case. The case slides apart slightly giving better access to the two levels of bits."



### DESIGNED TO HOLD SCREWS, WASHERS, NUTS, AND BOLTS

The **Matco Tools 2-pack 6" Magnetic Collapsible Cups**, No. MM6HCUP2, are designed to hold screws, washers, nuts, and bolts. Features a soft magnet bottom base that holds parts inside the tray, as well as holds the tray to ferrous surfaces. The modular clips allow trays to be connected together in order to create sets for larger projects. The cups are collapsible and expandable for easy storage, are dishwasher safe, and come in a green, red, or orange color.

Circle 25 on card or click "PTEN e-inquiry" on [VehicleServicePros.com](http://VehicleServicePros.com)

### DEFLECTS AND ABSORBS IMPACTS

The **Magid T-Rex Flex Series Lean Impact Glove**, No. TRX449, is designed to deflect and absorb impacts. It features a machine knit cut A4,13-gauge Hyperon shell for breathability, comfort, and cut protection. The crinkle latex palm coating offers ideal wet and dry grip, ideal for conditions where oils and liquids might be present so workers can switch from one task to another without changing their gloves. The flat para-aramid reinforced thumb saddle enhances durability at a critical wear point. It also features the Flex Series Lean M-Force Defense System for back-of-hand protection. The glove is touchscreen compatible and machine washable.

Circle 24 on card or click "PTEN e-inquiry" on [VehicleServicePros.com](http://VehicleServicePros.com)

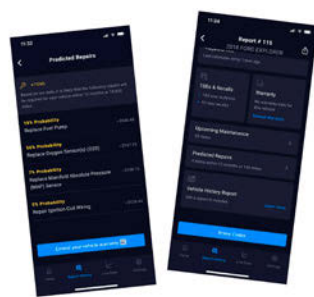

### OFFERS FUNCTIONALITY FOR NON-TOOL OWNERS

The **Innova RepairSolutions2 App Update** now offers functionality for individuals without Innova OBD-II scan tools. Users without an Innova scan tool can skip the "pair tool" function and just enter the vehicle's VIN and mileage. For users with an Innova scan tool, the user experience has been updated, including easy-to-understand error code data and updates to the live data information. The updated app also features icons with brighter colors to indicate vehicle status; an option to quickly change which vehicle is being viewed; and a more customizable dashboard. The app can be downloaded for free from the Apple app and Google Play stores.

Circle 26 on card or click "PTEN e-inquiry" on [VehicleServicePros.com](http://VehicleServicePros.com)

### FEATURES FOUR OUTPUT MODES

The **Milwaukee Tool Redlithium USB Stick Light with Magnet**, No. 2128-22, features four output modes: Front, back, dual, and inspection. Designed with 220 degrees of vertical light head rotation and paired with a slim light blade design and inspection light, the light is ideal for tight spaces, such as working around the engine. The Stick Light is IP54 rated for protection from most chemicals, and is impact resistant for drops up to 6'. Additionally, the light emits 550 lm on high with a run-time of two hours and 250 lm on low with a run-time of five hours.

Circle 27 on card or click "PTEN e-inquiry" on [VehicleServicePros.com](http://VehicleServicePros.com)



Watch this product in action here: [VehicleServicePros.com/21276871](http://VehicleServicePros.com/21276871)

### INSTALLS THE FRONT SEAL AND WEAR SLEEVE

The **OTC Front Seal Installer**, No. 5863, is designed to install the front seal and wear sleeve on select Navistar VT and MaxxForce engines. Includes a seal installer cup and pilot, a hex nut, a washer, a thrust bearing, and two socket head cap screws. The dimensions are 7.2" width by 5.8" depth by 5.8" height, and weighs 4.5 lbs. Made in the U.S.A.

Circle 28 on card or click "PTEN e-inquiry" on [VehicleServicePros.com](http://VehicleServicePros.com)







FOR MORE INFORMATION ON THESE PRODUCTS,  
CLICK ON "PTEN E-INQUIRY"  
at [VehicleServicePros.com](http://VehicleServicePros.com)  
OR CIRCLE THE NUMBER ON THE CARD.

**NEW PRODUCTS**



## USES LASER POSITIONING AND RANGING

The **Launch Tech X-431 ADAS Pro Plus** is designed to support the calibration of various ADAS systems in passenger cars from more than 50 vehicle manufacturers. The stand is made of light-weight, aluminum alloy material that is resistant to oxidation. The ADAS Pro Plus uses laser positioning and ranging, allowing the target to be placed accurately and quickly. The stand's main bracket can quickly fine-tune the position of the target in the horizontal, front/rear, left/right directions, with high precision and simple operation. The equipment adopts a modular design concept, and the stand alignment to the vehicle doesn't need a skilled technician to operate.

**Circle 29 on card or click "PTEN e-inquiry" on [VehicleServicePros.com](http://VehicleServicePros.com)**

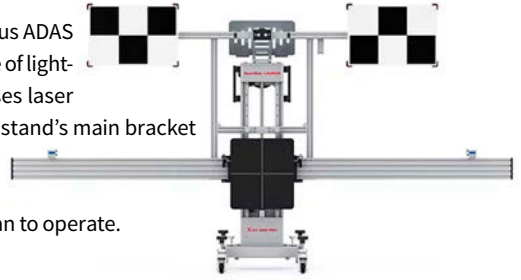

## ABLE TO SAVE AND RECALL FAVORITE WELD SETTINGS

The **Miller Electric Dynasty 300 Multiprocess Wireless Foot Control Complete** features AC/DC TIG, pulsed TIG, stick, air carbon arc, MIG, and flux-cored processes. With its intuitive interface LCD display, weld operators can quickly and easily adjust parameters. The welder has the ability to save and recall favorite weld settings, and offers locks and limits to provide control of the weld parameter ranges minimizing deviations from the welding procedure specifications (WPS). For portability and reliability, the inverter power supply allows for any single-phase input voltage hookup (208-600V) with no manual linking. It also includes a USB port to easily update software, a high-frequency arc starter for non-contact arc initiation, and an on-demand cooling system.

**Circle 30 on card or click "PTEN e-inquiry" on [VehicleServicePros.com](http://VehicleServicePros.com)**

### INCLUDES:

- Coolmate 1.3
- Small runner cart
- Adjustable shoulder strap
- Two Dinse/Tweco adapters
- Two 50mm Dinse style connectors
- 8' weld cable with Tweco-style connectors to power feeder
- 8' primary cord

**FREE**  
**20 oz. Tumbler**  
With Minimum \$100.00 Purchase

**With Over 2,500 Specialty Tools In Stock**  
**OEMTOOLS® HAS YOU COVERED!**

Scan QR code or search <http://bit.ly/COVEREDSEPT22>  
Use promo code: **TUMBLER** at checkout.

**Offer expires November 30, 2022**

Offer good while supplies last. Void where prohibited by law. Offer may not be applied to prior purchases. This offer is not transferable. \$100.00 purchase excludes tax and shipping fees.

**Circle 31 on card or click "PTEN e-inquiry" on [VehicleServicePros.com](http://VehicleServicePros.com)**



**BUILT-IN POWER BANK**

The **Davinci 8000 Rechargeable Flashlight** from **NEBO Tools** is constructed from anodized aircraft-grade aluminum, and emits up to 8,000 lm. The rechargeable light is IP67-rated and has a built-in power bank to allow users to charge their phone or other USB devices. Featuring optimized COB technology, the DAVINCI 8000 has five light modes, including: Turbo (8,000 lm), high (4,000 lm), medium (2,000 lm), low (80 lm), and strobe. It also offers Smart Power Control, Smart Temperature Control, and a magnetic mode select dial to easily cycle through all the modes. It also has an adjustable 4x zoom to go from a floodlight to a spotlight and vice versa.

**Circle 32 on card or click "PTEN e-inquiry" on VehicleServicePros.com**



**PROTECTS WORK AREA FROM MESSY OIL SPLATTERS**

The **Lisle Corporation No Splatter Pad with Supports**, No. 38800, protects work areas from messy oil splatters. The porous material of the splatter pad allows fluid to quickly pass through into the pan. The pad material resists engine oil, transmission fluid, coolant, brake fluid, brake cleaner, gear oil, and other solvents. The pad is not for coolants or fluids that will be recycled in the vehicle. Material fibers of the splatter pad may contaminate the fluid.

**Circle 33 on card or click "PTEN e-inquiry" on VehicleServicePros.com**



**INCLUDES SEVEN ENERGY-EFFICIENT MODELS**

The **Cool Boss Portable Evaporative Air Coolers Line** includes seven energy-efficient models designed to cost-effectively keep workers cool and safe from heat-related injuries. All Cool Boss air coolers are equipped with oversized pumps and fan motors, as well as automatic low-level shutdown valves to prevent pump burn-out. The Cool Boss lineup consists of two series. The four COOLBREEZE portable air coolers are compact and feature automatic swing louvers to provide complete control over where the chilled air goes. The larger COOLBLAST commercial-grade models have fixed louvers for precise directional cooling. All units have a soft-touch LED control panel.

**Circle 34 on card or click "PTEN e-inquiry" on VehicleServicePros.com**



**WORKS WITH STANDARD SHOP AIR**

The **OEMTOOLS 2L Pneumatic Vacuum Brake Bleeder Tool with Automatic Refilling Bottle**, No. 22506, is designed to simplify brake service. The Brake Bleeder Kit accurately tests and services many different pressurized systems on a vehicle. It works with standard shop air and includes: 40" silicone bleed hose with a universal rubber adapter that is compatible with most standard and ABS brake systems, 59" master cylinder evacuation hose for bleeding brake in master cylinder, and a transparent drain hose for visual inspection of fluid during bleeding. The kit easily bleeds brakes, tests automotive vacuum systems, and more.

**Circle 35 on card or click "PTEN e-inquiry" on VehicleServicePros.com**

**FOR BOTH WET AND DRY APPLICATIONS**

The **Makita 40V Max XGT Brushless Cordless 2.1 Gallon Wet/Dry Dust Extractor/Vacuum**, No. GCV01Z, is designed to provide a cordless solution for a range of applications. It functions in both wet and dry applications, with 148 cfm and 92" water lift for efficient performance. It's powered by one 40V XGT battery, but the two-battery bay will accommodate a second 40V battery for extended run-time. The vacuum has a variable speed control dial for power run-time and includes a 1-1/4" x 5-1/2" anti-static hose, a crevice nozzle with on-board storage, and an aluminum telescoping wand that adjusts to user height and collapses for storage.

**Circle 36 on card or click "PTEN e-inquiry" on VehicleServicePros.com**





FOR MORE INFORMATION ON THESE PRODUCTS, CLICK ON "PTEN E-INQUIRY" at [VehicleServicePros.com](http://VehicleServicePros.com) OR CIRCLE THE NUMBER ON THE CARD.

**NEW PRODUCTS** 



**BUILT-IN REGULATOR FOR CONTROL**

The **AIRCAT 812-RW 3/8" Impacting Ratchet** provides 80 ft-lb maximum torque to handle a wide range of applications. Features include: a 350 rpm run-down speed with built-in regulator for control, an internal impact mechanism that eliminates torque reaction and risk of finger trapping, and a composite handle grip to increase operating comfort. Additionally, it uses patented muffler technology that operates at 79 dBA, has a push and lock forward/reverse switch, and is made with needle bearing construction for reliability. **Circle 38 on card or click "PTEN e-inquiry" on [VehicleServicePros.com](http://VehicleServicePros.com)**



**FITS THE PALM OF A USER'S HAND**

The **Bosch 12V Max Brushless 3" Angle Grinder**, No. GWS12V-30N, features a compact design to make quick, difficult cuts in tight spaces. It produces 19,500 no-load rpm at 1.5 lbs (not including battery). The grinder was engineered to fit the palm of a user's hand, for ergonomics and control. Its spindle-lock design provides fast wheel change; simply pull the locking clip and unscrew the spindle screw. The grinder has restart protection to help prevent accidental start-up and overload protection to reduce the risk of the motor overloading or overheating. It also features fast braking time, stopping the wheel after the grinder is turned off.

**Circle 37 on card or click "PTEN e-inquiry" on [VehicleServicePros.com](http://VehicleServicePros.com)**

**CUSTOMER REVIEW:**  
 "Awesome little tool, very lightweight and easy to use. Only downside is no LED light, so a bit sub-optimal for low light conditions. Nice powerful, brushless motor and nice pivoting guard too."

**STREAMLIGHT**  
**WORK LIGHTS**



FLIPMATE®

STINGER SWITCHBLADE®

STRION SWITCHBLADE®

SYCLONE®

**Inspect, Identify and Repair.**

Get the ultimate in brightness and versatility with a broad selection of lights for delivering precise lighting or illuminating large areas. Fewer trip hazards and unlimited portability mean you can work harder for longer. All backed by more than 45 years of Streamlight's commitment to the industry.



[STREAMLIGHT.COM/WORKLIGHTS](http://STREAMLIGHT.COM/WORKLIGHTS)

© 2022 STREAMLIGHT, INC. ALL RIGHTS RESERVED.

**Circle 39 on card or click "PTEN e-inquiry" on [VehicleServicePros.com](http://VehicleServicePros.com)**

# Putting the 'A' in ADAS

A Rav4 case study highlights some of the challenges with repairing these advanced systems.

By **Scott Brown**, PTEN Technical Editor



▲ **Figure 1 – Onboard DAS puts a high priority on vulnerable road users.**

**D**river assistance systems (DAS) have been a part of the automobile going back many years with the introduction of such systems as ABS (antilock braking system), TC (traction/stability control), TPMS (tire pressure monitoring system), etc. Looking back, these systems had an impact on service because of the required product knowledge and oftentimes the adoption of new tooling to competently service such vehicles. Today, the common acronym we see is ADAS, which added the term “advanced” based upon the new features that either augmented the current DAS, or introduced brand new vehicle capabilities.

Many of these systems support active safety and go a long way towards preventing collisions and/or reduce the injuries received from a vehicular accident. In this article, you’ll learn about these systems, service challenges, and opportunities.

## **CAMERA SYSTEMS**

Cameras found on today’s vehicles naturally provide visual support not only for the vehicle operator but may support operations such as lane keeping, collision avoidance, and more. When you start to think about how these cameras work within these systems, you need to drop the assumption the camera sees exactly what humans see. Machine vision science is extremely sophisticated, and there’s a lot more than just photon detection going on behind the scenes. For many vehicle systems,

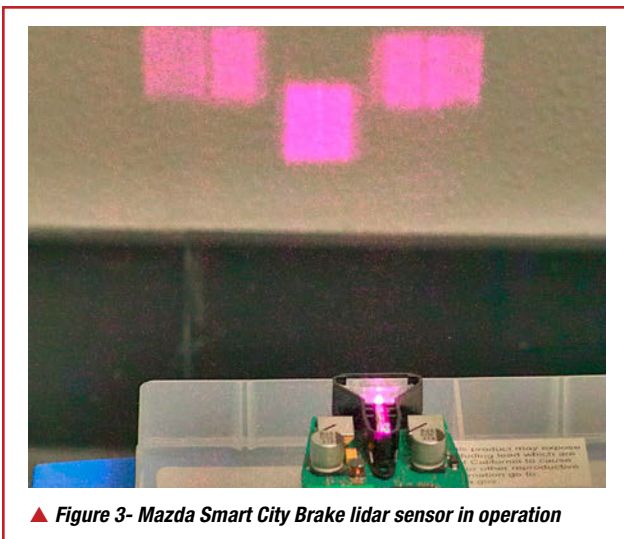
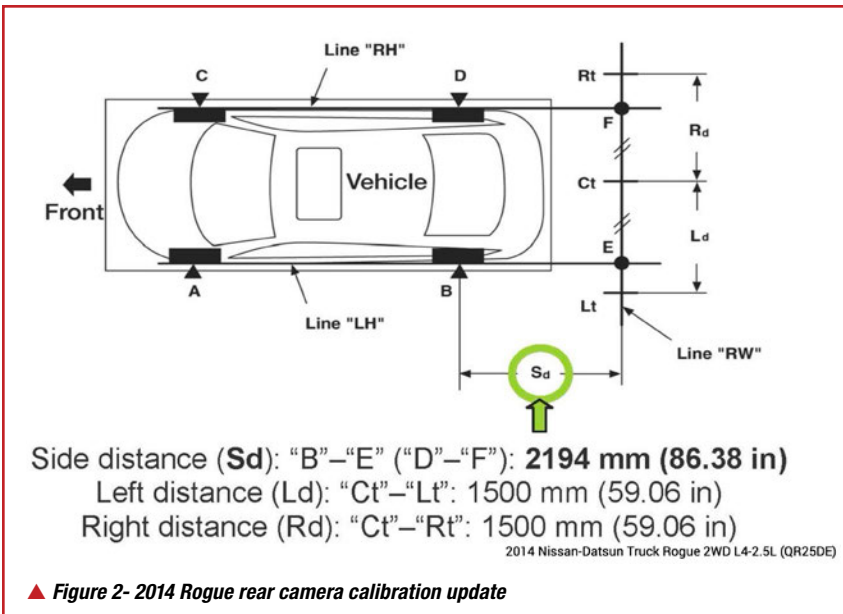

it's likely that the camera system is providing parallel layers of vision support simultaneously.

For example, a camera may be tasked with performing lane monitoring operations where a special filter is applied to the signal for processing lane markings and measurements as they relate to the vehicle they're mounted on. At the same time, there may be another service running that performs object detection and classification, and there may be a pose-detection program running tasked with estimating/predicting human movement around the vehicle. Humans on foot and on bicycles are considered vulnerable road users (VRUs) and are a high priority within the onboard DAS (Figure 1).

Cameras mounted high and center behind the windshield are mostly used for lane keeping and object detection/classification. However, I recently had a 2014 Nissan Rogue in the shop with lane departure warning (LDW) without a windshield area mounted cam-

era. Service information revealed this system will not work below 45 mph and is supported by the camera located at the rear of the vehicle. This is a SAE J3016 Level 0 vehicle, which means the system will only provide visible and/or audible warnings to the driver.

The rear camera is also used to support blind spot warning (BSW). Since this is a critical input for the proper operation of both systems, the camera is supported by a washer and blower system aimed at keeping the camera lens clean. In the event of low washer fluid, both systems will be temporarily disabled until the fluid reservoir is refilled. When calibrating the rear facing camera, please refer to bulletin NTB14-072 titled: "2014 Rogue; Target board placement for rear camera calibration." Under the notes section, you will find the following statement about operation:

"The Rear-View Camera monitors the traveling lane. It transmits the camera image signal to around view monitor control unit for the Lane Departure Warning (LDW) system."

The bulletin states the distances listed in the service manual are incorrectly supported by the following graphic (Figure 2).

### RADAR SYSTEMS

Radar sensors use electromagnetic radio waves to sense the distance to objects within its cone of rays by measuring the time of flight (ToF), and the incident angle between the transmitting (Tx) and receiving (Rx) antennas. Typically, the radar sensors used for adaptive cruise control (ACC) operate in the 77-81 GHz range. What this means is these radio chirps are being transmitted in the order of 77-81 billion times per second.

There are highly complex algorithms (usually taking place within the sensor) before its data is shared with other systems on the vehicle. The radar sensors used on the rear corners of the vehicle mostly operate at lower frequency ranges (24 GHz). Radar sensor that resides behind body panels is tuned specifically for that environment, so any changes to the body, repair, paint, etc. could negatively affect its operation. Consult service information for more information.

Additionally, these sensors are very delicate and most have a statement on the body saying they should be discarded if dropped. If you find yourself addressing one of these sensors that has been in a collision where the sensor and/or surrounding area suffered an impact equaling the shock from a drop, then a new sensor should be installed and properly initialized and calibrated.

### LIDAR – LIGHT DETECTION AND RANGING

Lidar works like radar, as it's using ToF of the near infrared light beams scattered out in front of the sensor. Since infrared is outside



▲ **Figure 4- Mazda short range lidar sensor**



▲ **Figure 5- Mazda short range lidar sensor; Smart City Brake support**

of the human’s visible spectrum, it’s hard to visualize what is happening in these wavelengths. **Figure 3** shows a blended image I was able to acquire using special filters and camera techniques.

Essentially, the systems are attempting to produce a spatial 3-D point cloud to establish where any hazards may exist. Although wide use of lidar is currently not the norm, there are several vehicle manufacturers who have adopted some form of lidar on their vehicle. One popular sensor can be found on Mazdas, Toyotas, and Volvos (**Figures 4 and 5**). (I recently published a video detailing a live

view of two different lidar sensors utilizing the Oculus which can be found here: [youtu.be/K7NRdwpqaAI](https://youtu.be/K7NRdwpqaAI))

**LIMITATIONS – ODD AND OEDR**

Today’s systems have numerous limitations, and as these systems evolve, their capabilities will improve. Service professionals should always refer to both the vehicle owner’s manual and service information before evaluating any complaints about system operation. The limitations may mirror the system complaint, which one

**RELATED PRODUCTS**

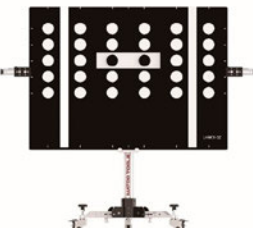

**Matco Tools**  
Portable ADAS Calibration Tool  
Circle 40 on card or click “PTEN e-inquiry” on VehicleServicePros.com



**TOPDON**  
Phoenix ADAS Mobile  
Circle 41 on card or click “PTEN e-inquiry” on VehicleServicePros.com

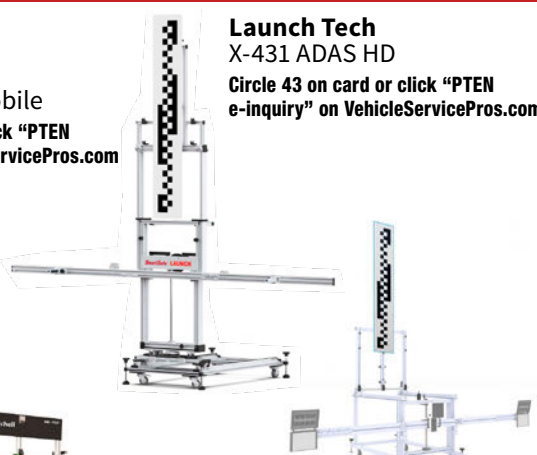

**Launch Tech**  
X-431 ADAS HD  
Circle 43 on card or click “PTEN e-inquiry” on VehicleServicePros.com



**Autel**  
Intelligent ADAS IA900WA  
Wheel Alignment and ADAS Calibration System  
Circle 42 on card or click “PTEN e-inquiry” on VehicleServicePros.com

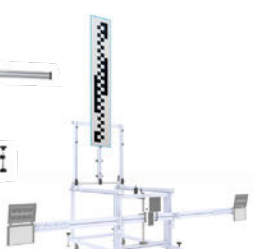

**Cojali**  
Cojali Jaltest ADAS  
Circle 44 on card or click “PTEN e-inquiry” on VehicleServicePros.com

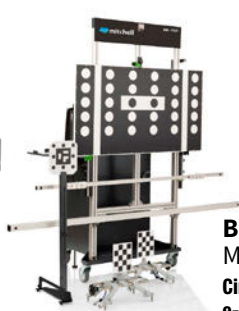

**Bosch**  
MD-TS21 ADAS Target System  
Circle 45 on card or click “PTEN e-inquiry” on VehicleServicePros.com



FOR MORE INFORMATION ON THESE PRODUCTS,  
CLICK ON "PTEN E-INQUIRY"  
at [VehicleServicePros.com](http://VehicleServicePros.com)  
OR CIRCLE THE NUMBER ON THE CARD.

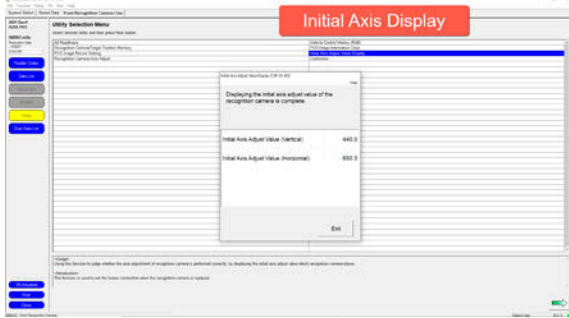

▲ Figure 6- Initial axis values on the lane camera

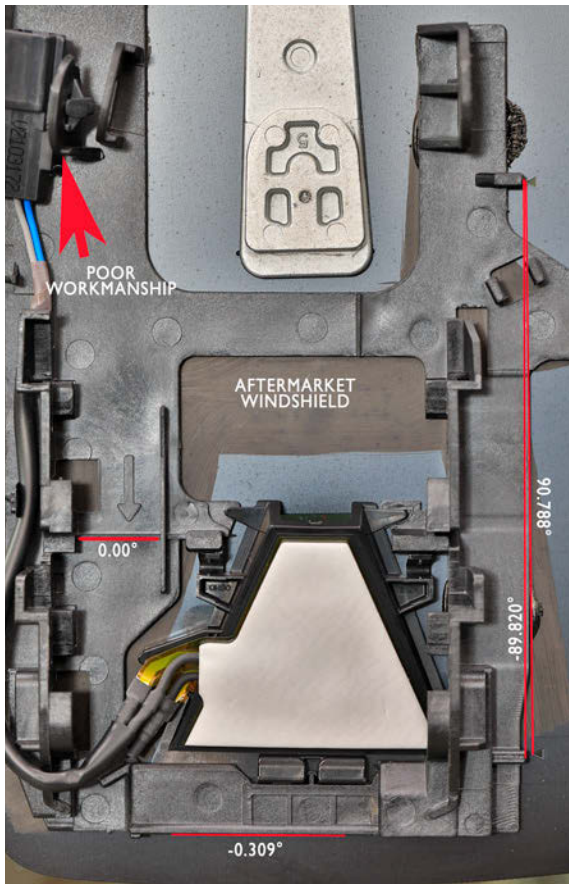

▲ Figure 7- Toyota Rav4 windshield aftermarket bracket

would then need to review with the consumer. Just because one vehicle can respond to a road condition doesn't mean all vehicles have the same capabilities.

## DIAGNOSTICS AND CALIBRATION

Many of the skills one needs for electrical and/or engine performance will serve well when addressing ADAS complaints and/or service requirements. If one wishes to gain a high level of competencies, then they should pursue training. Depending on the carline, you may have all the tools needed to address most diagnostic and service requirements.

**AUTEL MAXISYS™**

# TWICE AS NICE

THE ONLY FRAME TO PERFORM ADAS CALIBRATIONS & WHEEL ALIGNMENTS

## INTELLIGENT ADAS IA900WA FRAME

The Next Step In ADAS Calibration Now Includes Wheel Alignment Technology. One Frame To Perform 4-Wheel Alignment & ADAS Calibration.

ADAS CALIBRATION

AUTO HEIGHT TRACKING

WHEEL ALIGNMENT

6 HI-RES CAMERAS

SELF-CALIBRATING

## IMPROVE SHOP EFFICIENCY & PROFITABILITY

- PRECISE OPTICAL MEASUREMENT WITH 6 HIGH RES CAMERAS
- SELF CALIBRATING CAMERAS, ALWAYS ACCURATE, EVERY TIME
- CAMERAS AUTOMATICALLY TRACK VEHICLE HEIGHT ON LIFT
- MAXISYS INTERFACE FOR WHEEL ALIGNMENT

WE SUPPORT  
**ICAR**  
TRAINING

WE SUPPORT  
**ICAR**  
SUSTAINING PARTNER



TEL: (855) 288-3587 • [USSUPPORT@AUTEL.COM](mailto:USSUPPORT@AUTEL.COM)  
[AUTEL.COM](http://AUTEL.COM) • [MAXITPMS.COM](http://MAXITPMS.COM) • [MAXISYSADAS.COM](http://MAXISYSADAS.COM)  
©2022 AUTEL U.S. INC., ALL RIGHTS RESERVED

Circle 46 on card or click "PTEN e-inquiry" on [VehicleServicePros.com](http://VehicleServicePros.com)

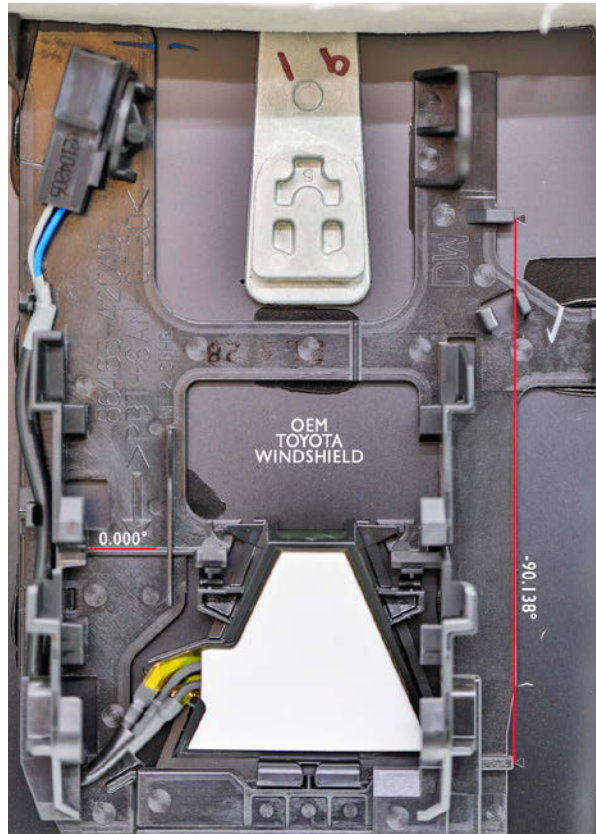

▲ **Figure 8- Factory Toyota Rav4 windshield OEM bracket**

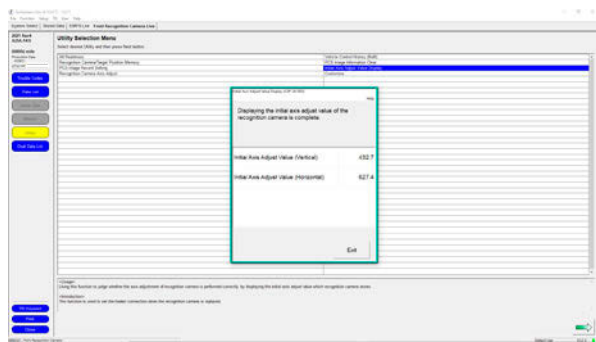

▲ **Figure 9- Axis values after new windshield and lane camera calibration**

Some vehicle manufacturers require special tooling such as static targets. Entering this market trying to become service-ready on every carline will be extremely challenging, but if you do your homework and find your addressable market, you'll be on your way to creating a business plan. However, there are a few items you should be aware of.

The primary consideration is workspace. Some operations such as static camera/radar calibrations require a large amount of workspace with an extremely level floor. Additionally, when static camera calibrations are required, certain lighting conditions may present challenges. Reference service information for best

practices around static camera calibration best practices. There are a number of aftermarket tooling solutions available. Personally, I have used the Autel Complete Solution (Red Frame w/cameras), the Bosch DAS3000, and others such as the John Bean EZ-ADAS. All three of these systems have focused on making the technician more productive without sacrificing accuracy. But beware, you should get in the habit of making sure that the target sizing aligns with what the manufacturer originally specified.

## CASE STUDY – 2021 TOYOTA RAV4

My shop had a client inquire about the behavior of their lane keeping system. Specifically, the lane tracing assist (LTA) system was allowing the vehicle's right-side tires to cross over the right-side lane lines. When in the lane keep assist (LKA) mode, the vehicle would warn the driver about approaching the left lane line about what one would expect, but for the right side, it was all happening well after the right-side tires passed over the lane lines. During the intake, we discovered the vehicle had recently had a replacement windshield installed, and this is when the symptoms surfaced. We commenced with analyzing the vehicle data by performing a complete health check, where there were no DTCs stored in any of the systems related to the complaints.

Using Toyota Techstream, we looked at the vehicle control history and could see that the vehicle recently had the camera calibrated, and the calibration process had been completed. We then looked at the initial axis value that was recorded during that calibration and saved a copy (Figure 6). Looking at the horizontal axis value had me concerned.

From my understanding, this is a pixel value used in establishing the baseline relationship to the imaging sensor with a known vehicle datum reference such as the vehicle centerline. The windshield mounted camera on this vehicle is vehicle centerline. I usually see these vehicles with that horizontal number in the ~630 range.

My next inspection was to look at the windshield branding. I found the windshield was from the same supplier as the OEM, but it was missing the OEM naming. I then decided to take a closer look at the camera mount, which is glued in place to the windshield to see if there were any noticeable challenges, and this is when I decided we were going to recommend a factory windshield. Figure 7 shows the mount wasn't properly indexed to the exact coordinates designated by the diamond shaped markers on the windshield.

If you look along the right side of the camera mounting bracket, you'll see two vertical lines that were used to measure the angles after establishing the reference line at 0.000 degrees at the horizontal line indicated by the arrow on the left side of the bracket. Also, you can see where the camera heater had to be transferred from the old windshield, which still had part of the broken camera mount attached to the harness at the top left.

We received approval to install a new OEM windshield and when we received it, I took an image of it for comparison (Figure 8).



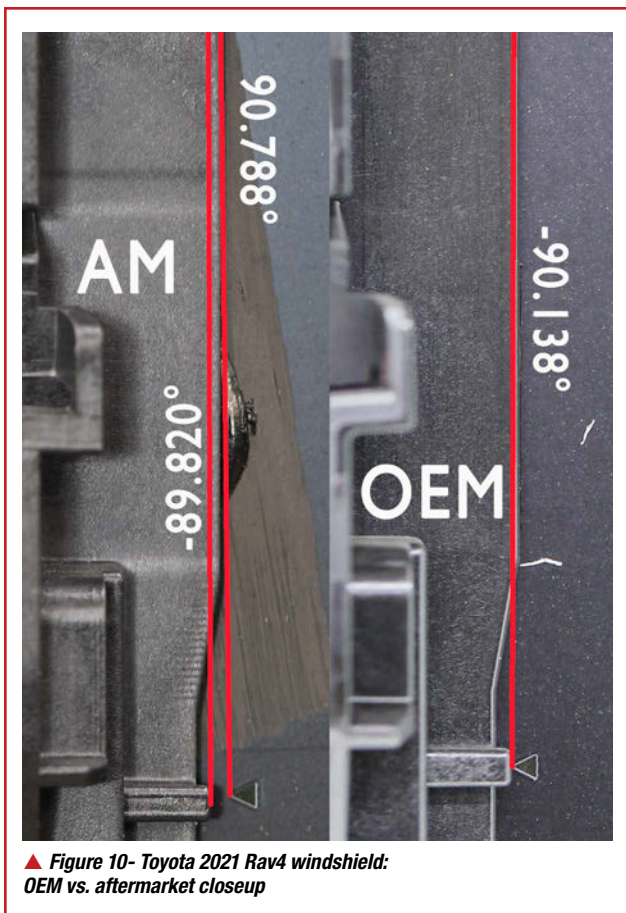

▲ Figure 10- Toyota 2021 Rav4 windshield: OEM vs. aftermarket closeup

After installation and camera calibration utilizing our Autel Red-Frame system, we recorded the initial axis values using Toyota Techstream, which produced the expected results (Figure 9). A thorough road test and performance analysis was performed on the LDW/LKA and found their operations well within the vehicle's ODD. Figure 10 shows a side-by-side comparison of the two camera brackets.

The current state of DAS will eventually lead us to automated driving systems (ADS). The suite of sensors on any given vehicle can be impacted by service operations. It's in your best interest to gain a high level of situational awareness to ensure the vehicles passing through your service bays are receiving the proper care and attention the OEM intended to happen. ❌



**SCOTT BROWN** is an ASE Master Certified L1 Technician and has over 37 years of professional service industry experience. He is an independent shop owner in Southern California and is engaged at various levels within the industry. He has a deep understanding of the challenges technicians experience at the service level and is continuously striving to move the industry forward through education and networking. Brown founded Diagnostic Network (diag.net) after 22 years of service at iATN, where he retired as company president in 2018.

[SBrown@VehicleServicePros.com](mailto:SBrown@VehicleServicePros.com)

**AUTEL® MAXISYS™**

# CALIBRATION CAPABLE

*CALIBRATING HAS NEVER BEEN  
SO PORTABLE & AFFORDABLE*

**TRAVEL CASES MAKE  
TRANSPORTING EASY**  
SOLD SEPERATELY, PART NO. MA600CASE

## MAG00FRAME

- FASTER FRAME SET UP
- INCREASE ACCURACY OF MEASUREMENTS
- 1 PERSON SET-UP & CALIBRATION

TEL: (855) 288-3587 • [USSUPPORT@AUTEL.COM](mailto:USSUPPORT@AUTEL.COM)  
[AUTEL.COM](http://AUTEL.COM) • [MAXITPMS.COM](http://MAXITPMS.COM) • [MAXISYSADAS.COM](http://MAXISYSADAS.COM)  
 ©2022 AUTEL U.S. INC., ALL RIGHTS RESERVED

Circle 47 on card or click "PTEN e-inquiry" on [VehicleServicePros.com](http://VehicleServicePros.com)

# The right tool for the engine job

When diagnosing fuel systems, the age of the vehicle will be a major player in which tool that you are going to be using.

By **Ross Colket**, Contributing Editor

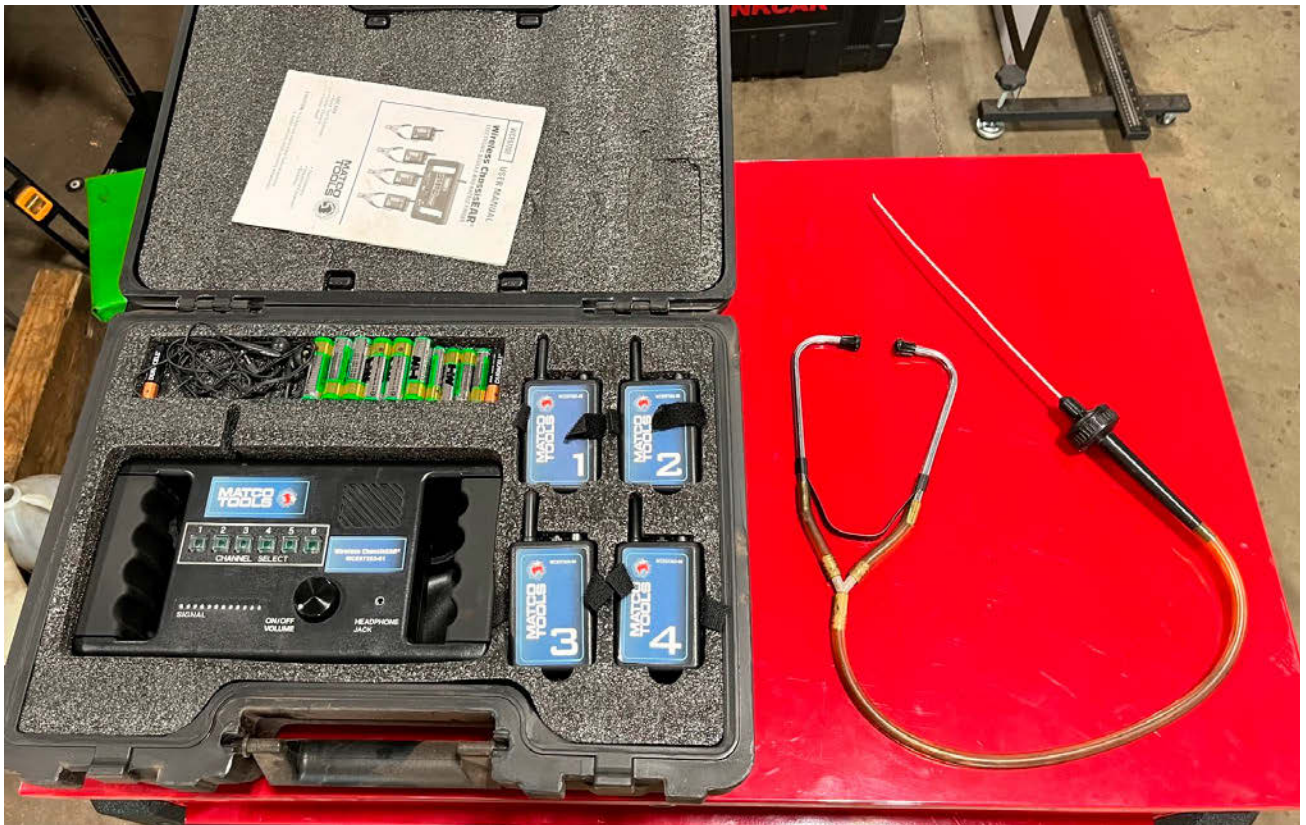

▲ **Figure 1-** A technician's stethoscope from Snap-on or Matco's Wireless ChassisEars are a great way to help pinpoint engine noise.

**T**he modern engine has become an increasingly more complicated system to diagnose and repair. When we begin looking at diesel engine emissions control systems and direct injection gasoline engines, it is a must that we have the proper scanners and test equipment to properly test and repair these vehicles.

Even today's sophisticated engine is still just a big air pump. The basics for an engine to run are air, fuel, compression, and spark. In the case of a diesel engine, the ignition is coming from compression. As the technician, it is your job to diagnose which of those requirements are the cause of the problem. Knowing which tool to use is key to a quick and successful diagnosis.

If you have a basic mechanical engine problem such as a noise or a rattle in

the engine, a technician's stethoscope from Snap-on or Matco's Wireless ChassisEars are a great way to help pinpoint the noise (Figure 1).

There are several engines out there today that have issues with the valvetrain. In many cases, you will have to resort to opening up the engine to see the specific damage (Figure 2).

In this picture, we can see a broken timing chain guide on a Ford 4.0L engine. ➔

# FEEL THE CHILL

CONTROL YOUR CLIMATE. JUST ADD WATER.™

BEAT THE  
**HEAT**  
SALE  
GOING ON NOW



See the full lineup at SEMA booth  
#37117 (South Hall Upper)



Bring Indoor Comfort Outdoors



26° F Cooling\*



Easy-to-use  
Control Panel



Large  
Cooling Area



Auto-refill

At Cool Boss, we focus on innovations that deliver incredible comfort and value. Every one of our COOLBREEZE™ and COOLBLAST™ evaporative coolers use tap water to instantly chill areas at a fraction of the cost of traditional air-cooling methods. Just plug them into a standard wall outlet, fill them with water, and instantly lower the surrounding temperature by as much as 26 degrees. It's that simple!

Learn more at [COOLBOSS.COM](http://COOLBOSS.COM) or call 1-855-2BE-COOL



Energy Efficient Warehouse Cooling

[WWW.COOLBOSS.COM](http://WWW.COOLBOSS.COM) • 1-855-223-2665

©2022 BendPak Inc. All rights reserved. BendPak® is a registered trademark.  
\*Your specific location may require a combination of multiple models and/or sizes to provide the most effective cooling experience.

 **COOL BOSS™**  
A Division of BendPak Inc.

Circle 48 on card or click "PTEN e-inquiry" on [VehicleServicePros.com](http://VehicleServicePros.com)

Eliminate chaos and clutter with the **ORIGINAL** socket tray *invented* by Hansen Global.

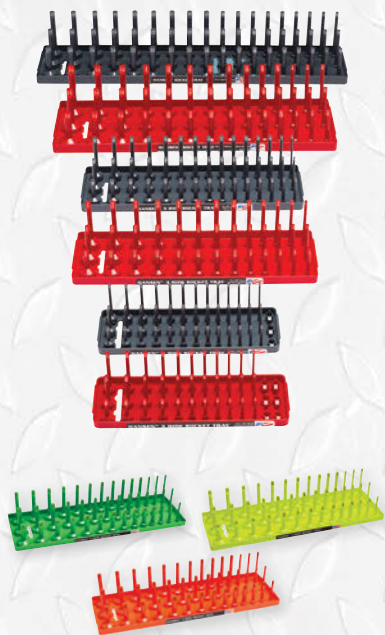

- Organize tools by size and style for easy identification.
- Secure regular, deep and semi-deep sockets all on one tray.
- All trays are molded from rugged ABS plastic to shrug off grease, chemicals, and other debris, and come with a lifetime guarantee.
- 3 row trays available in 1/2", 3/8" and 1/4" drive.
- 2 row trays available in red, gray, orange and green.



Proudly 100% made in the USA since 1995 – Lifetime Guarantee.

877-793-5213

[hansenglobalinc.com](http://hansenglobalinc.com)

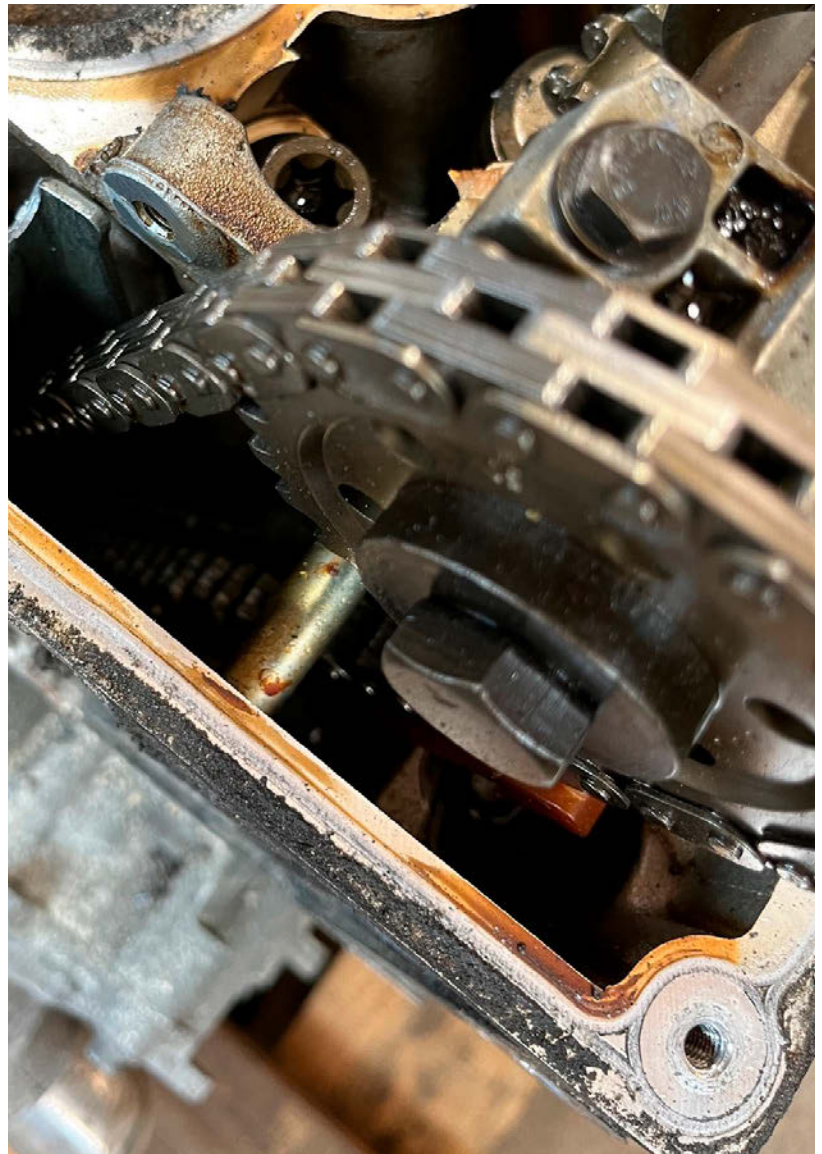

▲ Figure 2- Opening up the engine to see the specific damage to the valvetrain.

The customer's original concern was "A loud rattling noise from the engine." We used a stethoscope to find where the noise was loudest and took off that valve cover. Once inside the engine, it was easy to see the cause of the customer's concern. Due to the overall condition of the engine and the amount of metal from the guide circulating through the engine, we decided to install a used engine at the customer's request to correct the issue.

Next, we need to determine if it is air, fuel, or compression. As simple a tool as a vacuum gauge is, it's a great way to determine if you

should proceed further with a compression test or leak down tester. In Figure 3, we have a Matco Tools diesel compression tester on the left, a Snap-on gasoline engine compression tester in the middle, and a Star Products cylinder leakage tester on the right.

Before testing for proper air supply to the engine, it should be started with a simple visual inspection of the air filter. I have seen some air filter boxes entirely full of dog food or acorns. Those rodents can be pesky creatures when getting ready for winter. The interesting part is that those vehicles were driven on a regular basis

## »» TOOLS USED:

- AUTEL ULTRA SCAN TOOL
- SNAP-ON ZEUS OSCILLOSCOPE
- SNAP-ON LOW AMP CLAMP
- AES WAVE FUSE TAP
- AUTEL ULTRA'S MAXIFLASH VCMDI
- GM'S SERVICE PROGRAMMING SYSTEM
- MATCO MC9440 BATTERY MAINTAINER

(Don't assume — always perform that visual inspection).

Next, perform your engine vacuum test with a Mac Tools VG3000 vacuum gauge and check it against your specs for the vehicle. You will be able to determine if it is time to perform a compression test and possibly a cylinder leakage test with a Matco Tools CLT2APB to determine if it is an intake valve, exhaust valve, or a piston sealing problem. All of these tools are relatively inexpensive but mandatory for determining the basic mechanical integrity of the engine.

When diagnosing fuel systems, the age of the vehicle will be a major player in which tool that you are going to be using. On old carbureted cars, you will be using your vacuum/pressure gauge and looking for approximately 4 to 6 psi. If you recall fuel-injected cars from the '80s, you were looking for 35 to 60 psi. For today's cars, you are going to be using a scanner to verify high pressure fuel system pressures on both gasoline and diesel engine vehicles.

We do quite a bit of diagnostic and ADAS work at our shop, so as you can see from Figure 4, we have several Autel scan tools. We also have a Snap-on Zeus, Snap-on Vantage Legend, and a Thinkcar Platinum S20. The majority of these tools are used on a daily basis, allowing us to work on present model year vehicles.

Always refer to your information system to determine the proper fuel system test procedure and specification. Be careful, on your any of your vehicles with direct injection, the high-pressure fuel systems can cause severe

personal injury. Follow the specific repair procedures for the vehicle you are working on.

When it comes to testing ignition systems, I will always start with a code scan to see if I can determine the specific cylinder. The diagnostic systems on the vehicles these days are very good at pinpointing a cylinder in question, but not what is actual causing the specific problem. That's our

job. I will grab my oscilloscope to look at the current ramping of the coil packs.

The best part of individual coil packs is that you have several other examples of "known good examples". There are plenty of tools on the market that are pinpoint based testing on ignition coils, like the Blue Point YA76S62, and cost much less than an oscilloscope. In many cases you can

# TOPDON®

## THE ALL-IN-ONE AUTO-TECH TOOL



### Phoenix Max

ADAS  
Heavy-Duty Trucking  
Key Programming

## TOPDON®

WWW.TOPDON.US  
400 Commons Way, Suite A  
Rockaway, NJ 07866-2030



TOPDON USA SUPPORT  
SCHEDULE A DEMO 833-629-4832  
SUPPORT@TOPDON.US

©2022 TOPDON USA Inc.

Circle 50 on card or click "PTEN e-inquiry" on VehicleServicePros.com

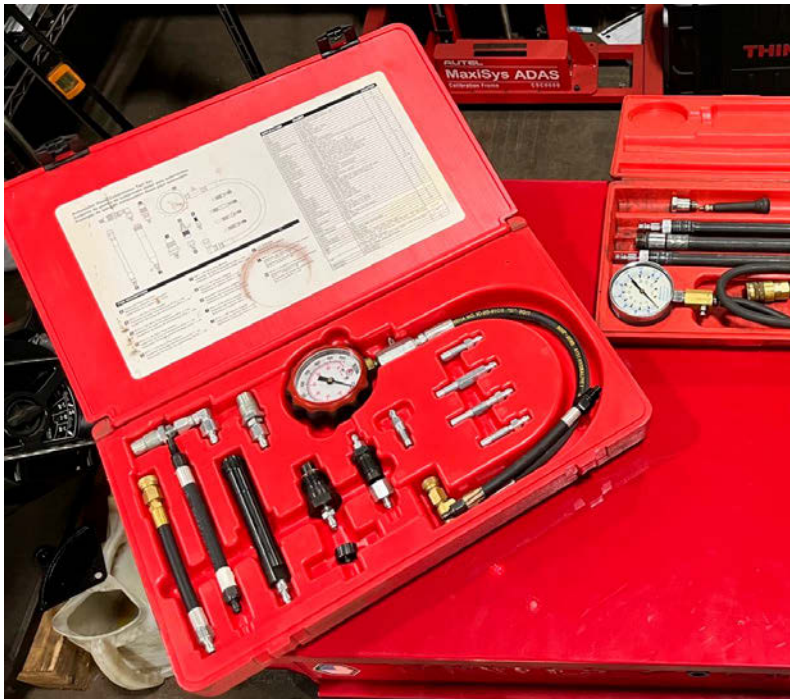

▲ *Figure 3- A Matco Tools diesel compression tester on the left, a Snap-on gasoline engine compression tester in the middle, and a Star products cylinder leakage tester on the right.*



▲ *Figure 4- The many Autel scan tools in our shop.*

even use a Fluke 88 automotive DVOM to test coil resistances and available voltage. Always check your service information for wiring diagrams when performing pinpoint testing on the ignition systems.

When we begin any diagnosis at my shop, we always start with duplicating the customer’s concern. If you cannot duplicate the concern, how are you supposed to find it? Once we have duplicated the concern, we will typically scan all the computers in the vehicle for trouble codes. Now that we have collected that data, we will go to Identifix (Figure 5) to look for TSBs, recalls, and common failures. We will use that as guidance when we begin testing the vehicle to confirm the concern.

We recently had a 2020 Chevrolet Silverado with the new 3.0L Duramax Diesel. The customer’s concern was the vehicle entering limp home mode with a service wrench light and check engine light. If the customer cycled the key, the service wrench light would reset. The vehicle had been to the dealer at least once for this concern but was unable to duplicate the concern. We were able to duplicate the customer’s concern but not on a repeatable basis. We grabbed our Autel Ultra scanner for the job since it will also provide a network Topology map when performing a full vehicle scan (Figure 6). We did find the vehicle to have three trouble codes related to the problem:

- P0202:00 Cylinder 2 injector control circuit
- P0216:00 Injection timing control circuit
- P0300:00 Random or multiple cylinder misfire

When checking the vehicle service information from Mitchell, we checked TSBs and found an applicable TSB for the engine wire harness having chaffing issues throughout the engine compartment. Our next step was to remove the left front inner fender liner to access the PCM and to gain access to the wire harness. The bulletin was very good at listing the rub points that were common, making our job easier.

We hooked up our Snap-on Zeus oscilloscope with the Snap-on low amp clamp and also a fuse tap from AES Wave

to the ECM fuse that provides power to the injectors (Figure 7).

Our goal was to monitor the voltage and current ramping of the injectors while performing a wiggle test on the harness. One technician performed the wiggle test while another technician focused on the oscilloscope. No problems were found during this test. We let the vehicle hot soak after a long road test and the problem occurred as soon as we restarted the vehicle.

As we continued the diagnosis, we could confirm the hot soak would trigger the problem every time (perfect, a bad PCM it is!). We replaced the PCM and reflashed it with the Autel Ultra's MaxiFlash VCMII and GM's Service Programming System. We did use a Matco MC9440 Battery maintainer for our power supply for the vehicle's stable voltage (Figure 8).

A quick side note, that battery maintainer is getting on the older side and can only handle 50A. It is recommended that

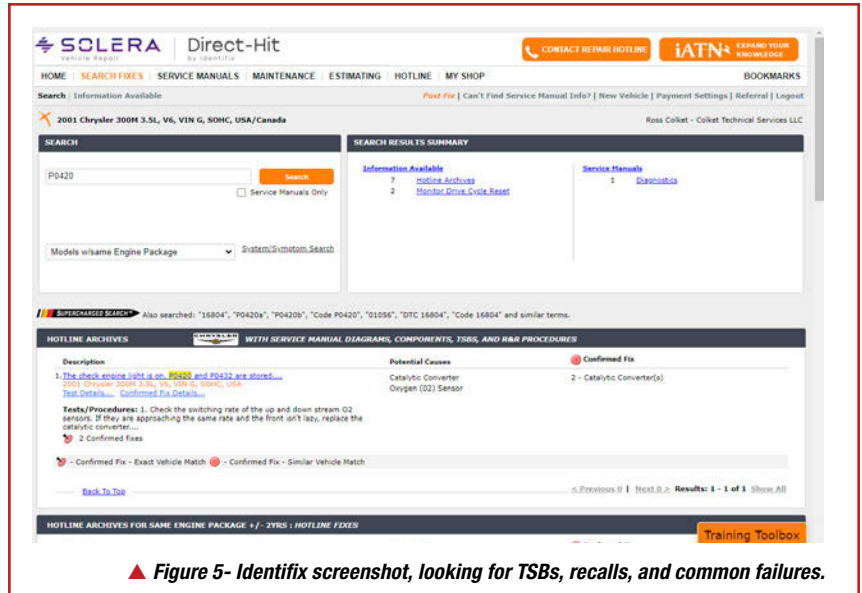

▲ Figure 5- Identifix screenshot, looking for TSBs, recalls, and common failures.

a 100A battery maintainer be used for today's cars, so we will be upgrading very soon. Vehicle was extensively road tested and verified to be fixed!

Remember, our time is money so understanding the systems you are working on is critical to making an accurate and fast diagnosis. Know your tools and how to

## REMOVING RUSTED AND OBSTRUCTED DIESEL NOx AND PARTICULATE SENSORS DOESN'T HAVE TO BE AN EXPENSIVE AND TIME CONSUMING PROBLEM ANYMORE!

### LT996D Shockit™ Socket Diesel NOx & Particulate Sensor Removal Kit

- Air hammer powered Shockit™ Sockets for removing rusted and obstructed diesel exhaust sensors
- Compact sizes for reaching sensors with restricted access
- Uses the force and vibration of an air hammer to loosen the most rusted sensors
- Includes non-turning offset 8mm radius tip LT1910P 11" Standard Shockit™ Punch
- Force and vibration of air hammer allows most sensors to be removed without thread galling
- Each Shockit™ Socket has 3 driving ears w/ 8mm indexed holes for delivering maximum rotational force
- Each Shockit™ socket has inverted indexed holes for tightening and loosening, allowing the most stubborn sensors to be worked back and forth during removal
- 22mm Shockit™ Socket removes NOx sensors on Chevy® Duramax, Dodge® Cummins, Ford® Power Stroke. Also removes most Semi Truck NOx sensors including Kenworth®, Cummins®, International®, Detroit & Volvo®
- 22mm Low Profile Shockit™ Socket for delivering maximum rotational force and minimum side loading for extremely stuck NOx sensors
- 22mm Thin Wall Deep Shockit™ Socket removes NOx sensors on Jeep® & RAM® ECO Diesel
- 24mm Shockit™ Socket removes Particulate Sensors (Soot Sensors) on Chevy® Duramax, Dodge® Cummins and Ford® Power Stroke
- 24mm Low Profile Shockit™ Socket for delivering maximum rotational force and minimum side loading for extremely stuck particulate sensors
- 30mm Shockit™ Socket removes the NOx sensor lock nuts on Jeep® and Ram® ECO Diesel
- Includes 20mm, 22mm & 27mm bottoming tap and dies for sensor and mounting hole threads
- Must be used with Shockit™ Punches for maximum performance and warranty coverage
- Additional Shockit™ Punches sold separately - LT1910PS 5.5" Short Punch, LT1910PL 22" Long Punch

**AIR HAMMER POWERED**

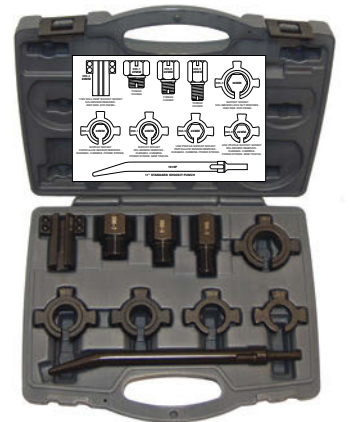

Patent #7,677,143

**NEW PRODUCT**



## EASILY REMOVE & INSTALL BENDIX/KNORR-BREMSE AIR DISC BRAKE PAD RETAINERS!

### LT891 Bendix/Knorr-Bremse Air Disc Brake Pad Retainer Tool

- The only tool made for servicing Bendix/Knorr-Bremse air disc brakes
- Provides safer and easier way to remove pad retainer
- Works with left and right side calipers
- Heat treated for strength and durability
- Designed to work with or without caliper shield
- Easy grip handle



Scan to see tool work!



Patent pending

**NEW PRODUCT**



LOCK TECHNOLOGY, INC.  
Toll Free 800-421-7241



Innovator of Great Ideas

www.litools.com  
litools@litools.com

Circle 51 on card or click "PTEN e-inquiry" on VehicleServicePros.com

www.VehicleServicePros.com © SEPTEMBER 2022 © PROFESSIONAL TOOL & EQUIPMENT NEWS

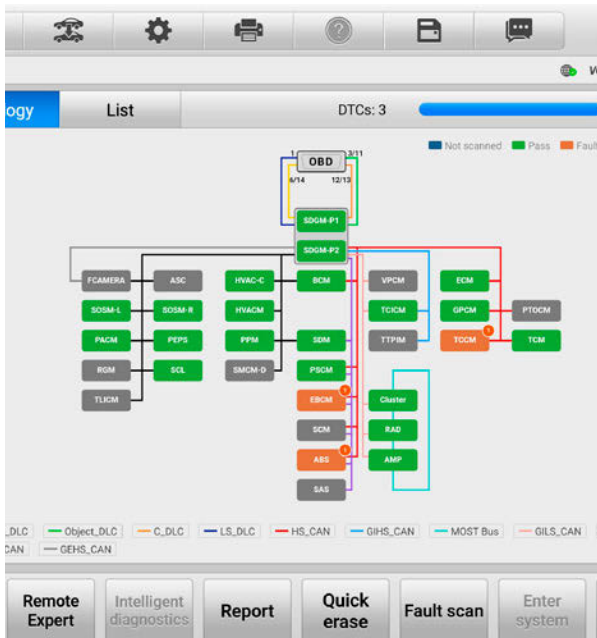

▲ Figure 6- A network topology map after performing a full vehicle scan.

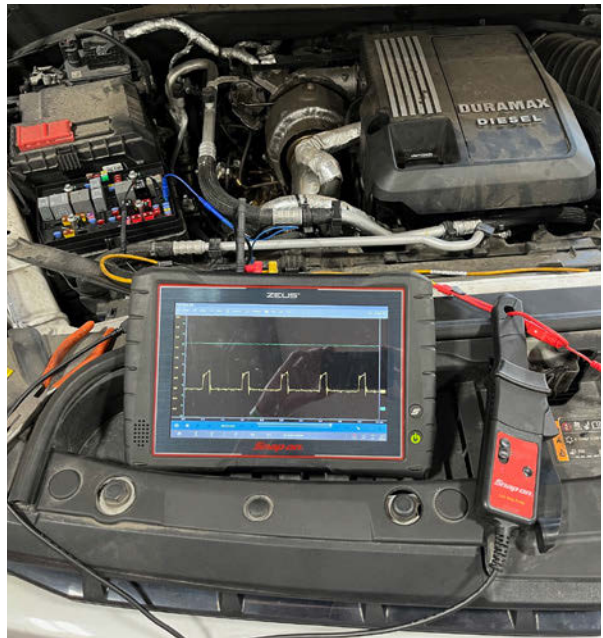

▲ Figure 7- We hooked up our Snap-on Zeus oscilloscope with the Snap-on low amp clamp and also a fuse tap from AES Wave to the ECM fuse that provides power to the injectors.

**»» RELATED TOOLS**



**OTC**

**Digital Compression Tester Kit**

Circle 52 on card or click "PTEN e-inquiry" on VehicleServicePros.com



**Snap-on**

**Pass Thru Assistant**

Circle 54 on card or click "PTEN e-inquiry" on VehicleServicePros.com



**Pico Technology**

**PicoScope**

Circle 55 on card or click "PTEN e-inquiry" on VehicleServicePros.com



**Opus IVS**

**Mongoose-Plus**

Circle 53 on card or click "PTEN e-inquiry" on VehicleServicePros.com



**Curien**

**A1 Low Current Amp Clamp**

Circle 56 on card or click "PTEN e-inquiry" on VehicleServicePros.com



FOR MORE INFORMATION ON THESE PRODUCTS, CLICK ON "PTEN E-INQUIRY" at VehicleServicePros.com OR CIRCLE THE NUMBER ON THE CARD.



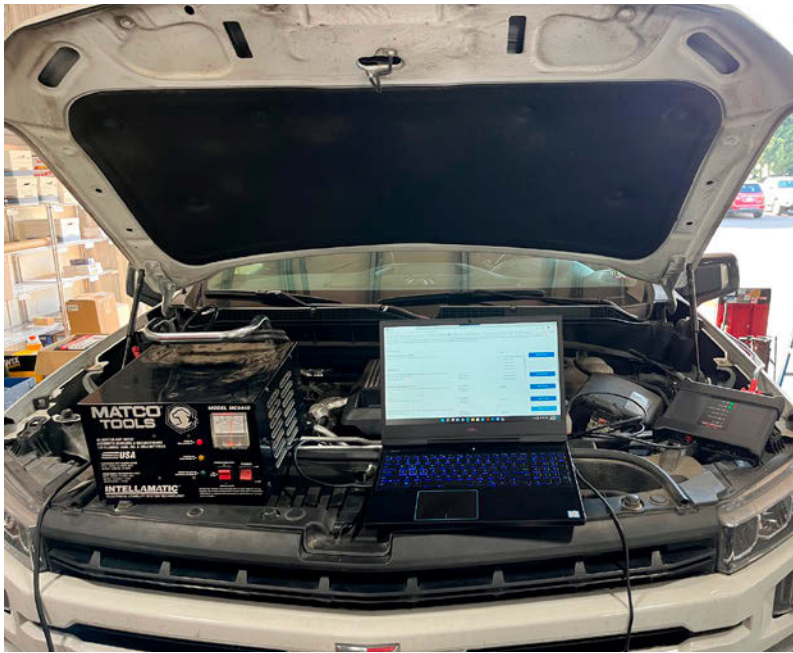

▲ Figure 8- A Matco MC9440 battery maintainer was used for our power supply for the vehicle's stable voltage.

use them efficiently. Sometimes, this will require training and simply working with the tool, so that when it comes time, you can effectively use it to locate the problem.

I recently attended an oscilloscope class, and I was surprised at the number of lead sets and even screen protectors that were in the audience. It was clear that many of the oscilloscopes were being used for the first time. It will be very challenging for a technician to find a problem with a vehicle if they aren't comfortable with their tool of choice. ❌



**ROSS COLKET** is the owner of Colket Automotive Technical Services in Lansdale, Pennsylvania. He is an ASE Certified Master Technician with over 30 years of experience as both a technician and educator. As a former CTI instructor, he believes in the importance of training and giving back to the industry.

[Ross@ColketTech.com](mailto:Ross@ColketTech.com)

# COAST<sup>®</sup> PROFESSIONAL XPH SERIES HEADLAMPS

RECHARGEABLE, HANDS-FREE LIGHTING FOR SMARTER AUTO SERVICE



PURE BEAM<sup>®</sup>  
FOCUSING



COASTPORTLAND.COM



XPH34R | 2075 LUMENS



XPH30R | 1000 LUMENS



XPH25R | 410 LUMENS

Circle 57 on card or click "PTEN e-inquiry" on [VehicleServicePros.com](http://VehicleServicePros.com)

# Matco Tools 6" Random Orbit Palm Sander 3/16"

Reviewed by Lou Fort, lead technician at K.A.R.S. Inc. in Huntingburg, Ind.



**Q: What kind of setup was involved before using the product?**

**A:** Setup is simple. Attach your choice of air supply (be it a nipple or hose), set the desired speed dial, and slap your choice of friction disc on the pad.

**Q: How was its packaging? Did it come with any accessories?**

**A:** The MT2516 comes in a heavy cardboard box with several pictures of the sander and features called out. It comes with a wrench for removing the friction pad.

**Q: Was there a manual included?**

**A:** Yes, there is a manual and warranty registration card. I didn't find the manual to be of much use. Some may find the information given for attaching a vacuum kit helpful though.

**Q: What features did you like?**

**A:** The most liked feature is the wrist rest on the tool. Next would be the directional exhaust and low vibration and noise level.

**Q: What types of jobs did you use this tool for?**

**A:** I have used the Matco palm sander in a wide variety of surface prep work from body panels, trailer beds and frames, and one home wood project so far.

**Q: Have you used a previous version of this tool?**

**A:** I have, currently, a few different orbital palm sanders. This is the only one with a built-in wrist rest. They all have variable speeds, directional exhaust, etc., although one has a detectable, dust collection attachment built in.

**Q: Is there any way you could think to improve or add to the tool?**

**A:** I think a reversible friction disc pad would be interesting. A reversible

motor would also be nice. I'm also not a huge fan of hook and loop friction disc pads. I prefer adhesive pads over hook and loop.

**Q: On a scale of 1 to 10, how would you rate this tool overall? Why?**

**A:** The Matco Tools 6" Random Orbit Palm Sander 3/16", No. MT2516, is a solid 10 palm sander. Matco has made a professional-level tool that promises a long life from heavy use and combined it with features that make it more comfortable to use than other options. 

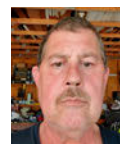

**LOU FORT** has worked in the automotive industry for 47 years and is the lead technician at K.A.R.S. Inc. in Huntingburg, Indiana. Throughout his career, he has worked for Ford, GM, and Chrysler dealerships, but the majority of his time has been spent on the independent side. Fort holds an associate's degree in applied science, along with a year spent studying mechanical engineering.

## PRODUCT DESCRIPTION

The **Matco Tools 3/16" Random Orbital Pneumatic Low Noise 6" Palm Sander**, No. MT2516, features 3/16" random orbit action for fine sanding. The integrated wrist support and rubber overmold helps improve grip retention and comfort during extended use. The composite motor housing and double sealed bearing provide true oil-free motor design, reducing tool maintenance, and the precision balanced pad provides reduced vibration and smooth action during use. Sand quietly with the optimized internal air path and low noise muffler design.

**Circle 58 on card or click "PTEN e-inquiry" on VehicleServicePros.com**

This product was given to the reviewer free of charge from the manufacturer.



FOR MORE INFORMATION ON THESE PRODUCTS,  
CLICK ON "PTEN E-INQUIRY"  
at [VehicleServicePros.com](http://VehicleServicePros.com)  
OR CIRCLE THE NUMBER ON THE CARD.

# Ullman Devices Magnetic Rails

Reviewed by Brian Culotta, shop foreman/master technician at Dave's Auto Care in Willoughby, Ohio.

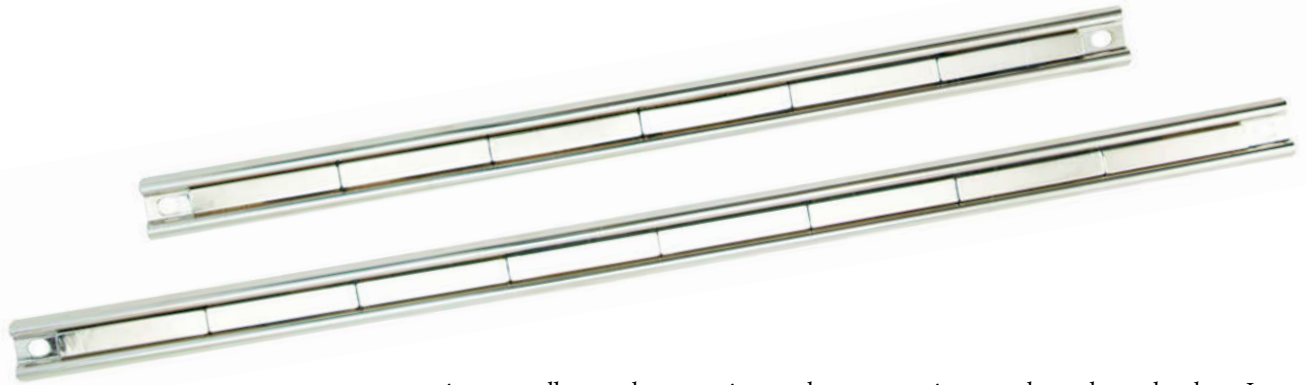

**Q: How did the tool function as far as saving you time?**

**A:** Having your tools readily available when needed, while also stowed away when not, is key to maintaining a smooth working environment. These magnetic rails provide a quick "home" to stow away my frequently used tools.

**Q: How has using this tool impacted your shop's profitability?**

**A:** As always, time is money. The less time we spend sifting through cluttered drawers

in our toolboxes, the more time we have available to repair vehicles. I try to be as organized as possible with my tools, so this product fit my tendencies quite nicely.

**Q: What kind of setup was involved before using the product?**

**A:** The magnetic rail must be permanently mounted to the surface in which you want to mount it to. I decided to rivet the rails to my service cart. Now I have a permanent home for my most common daily used tools.

**Q: How easy was it to use?**

**A:** Very simple. Mount the rail and place a metallic tool near the product. Nothing complex here. It's a magnetic rail.

**Q: Was there a manual included?**

**A:** There were not any instructions included in the product, nor did I feel it necessary for there to be. The product is self-explanatory.

**Q: What features did you like?**

**A:** The strength of the magnets within the rail are impressive! I have yet to find a metallic object that wouldn't be supported by the magnets. When transporting my

service cart throughout the shop, I can trust these magnets will not let go of the tool I have secured. They are very strong.

**Q: How does this tool compare to other tools you've used like it?**

**A:** I have other magnetic trays, but they do not have the magnetic strength of this rail. This rail uses a strong N35 Neodymium rare-earth magnet.

**Q: Is there any way you could think to improve or add to this tool?**

**A:** The product could have come with mounting hardware. I decided to use rivets to mount the rail to my tool cart but hard to purchase them separately. A small pack of rivets or machine screws would be nice to use to mount the product. ☒



**BRIAN CULOTTA** is a graduate of the Universal Technical Institute in Chicago, Illinois. After graduating, he started working for an independent car dealership as a lead technician for seven years. He then moved to a new job at an independent repair shop where he stayed for three years. He now works at Dave's Auto Care in Willoughby, Ohio, as the shop foreman and ASE Master L1, L3 technician.

This product was given to the reviewer free of charge from the manufacturer.

## PRODUCT DESCRIPTION

The **Ullman Devices Magnetic Rails**, Nos. UMR13 and UMR17, use strong N35 magnets to mount to benches, boxes, and vehicles to securely hold sockets and metal tools. The rails also have mounting holes to adhere to walls and other non-magnetic surfaces. The UMR13 measures 13-1/4" in length while the UMR17 measures 17-1/4" in length.

Circle 59 on card or click "PTEN e-inquiry" on [VehicleServicePros.com](http://VehicleServicePros.com)

# Milwaukee Tool M18 Inflator

Reviewed by Eric Moore, fleet manager at Griffin Pavement Striping in Columbus, Ohio.

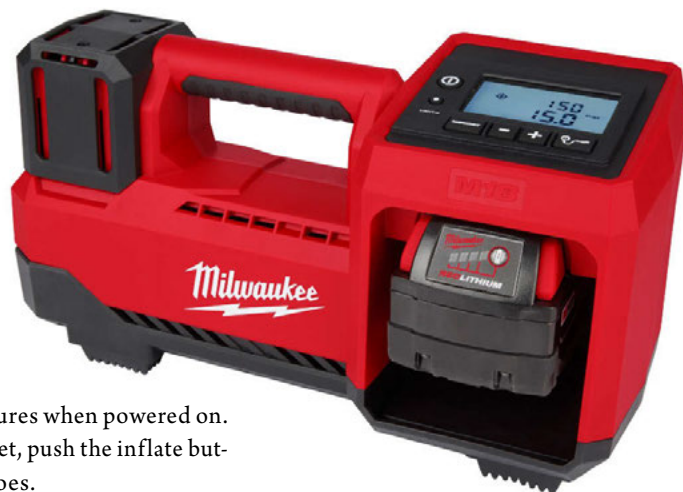

**Q: How did the tool function as far as saving you time?**

**A:** The Milwaukee Tool M18 Inflator is a portable, cordless unit that makes it very handy and a good choice for quick inflations, adding air to the proper pressure for low tires on most commonly driven vehicles. No cords and plenty of guts with the M18 fuel battery selection.

**Q: How has using this tool impacted your shop's profitability?**

**A:** Being portable did make it pretty quick to just top off low tires on our light duty vehicles. There was no waiting for another driver to move their vehicle away from the airline access.

**Q: How easy was it to use?**

**A:** The M18 Inflator is very simple, and the display reflects that. It shows cur-

rent and set pressures when powered on. Once pressure is set, push the inflate button and away it goes.

**Q: What kind of setup was involved before using the product?**

**A:** Once unboxed, inserting a charged battery and choosing the desired adapter was all it took, and it was ready to work.

**Q: How was its packaging? Did it come with any accessories?**

**A:** Packaged in a branded box, it comes with four adapters: a brass female Schrader adapter, plastic male Schrader adapter, plastic nozzle for pool toys or other inflatables, and a needle for sports balls.

**Q: Is there any way you could think to improve or add to this tool?**

**A:** This inflator is actually pretty stout as-is. If I had one suggestion it would be a slightly longer hose, or an extension. That could make on-board storage a little trickier, and it's fine the way it is.

**Q: What types of jobs did you use this tool for?**

**A:** I used the M18 Inflator at home on several of my motorcycles, a vintage 1962 Corvette, a fitness ball, and on several of our light duty trucks at the shop. Only a few tires were completely flat, the rest were simply topping off low pressures.

**Q: What features did you like?**

**A:** The best features of the M18 Inflator are its weight and capabilities. This is a very well-rounded tool. It comes in just under 9 lbs with a 5Ah M18 battery, so

it's easy to carry around without getting worn out. It's actually pretty quiet compared to the power outlet adapter air compressors we've all used or have in the trunk somewhere.

**Q: How does this tool compare to other tools you've used like it?**

**A:** I think we've all used the portable inflators that plug into the power outlets in our cars at one time or another, and this M18 Inflator is far and away a better tool — better design and much more capable. It's also lighter, faster, and more reliable.

**Q: On a scale of 1 to 10, how would you rate this tool overall? Why?**

**A:** Putting numbers on this is difficult, it's a great addition to your toolbox or trunk. And to be fair I'll rate it a solid 8.9. The only reason it doesn't make 10 is because it doesn't do heavy duty tires. The pressures are too high, and I bet the pump would explode if attempted. ❌



**ERIC MOORE** began his career working on cars at several franchise dealerships. Initially, he leaned towards smaller vehicles, settling into Powersports vehicles, where he stayed for over 20 years. Then, Moore went the total opposite direction, landing at a medium and heavy duty truck dealership. Eventually, he moved into management and has performed most roles at the dealership level except for owning his own franchise. Currently, he is the fleet manager at Griffin Pavement Striping, belonging to the Frontline Road Safety group of companies.

## PRODUCT DESCRIPTION

The **Milwaukee Tool M18 Inflator** is an 18V cordless tire inflator designed to meet the needs for transportation maintenance professionals by providing ideal performance, versatility, and the durability to survive demanding jobsites. With the 150 psi maximum capability, users can fill tires quickly. Additionally, the inflator is equipped with TrueFill auto shut-off technology that has the accuracy to be set at a specific psi which will automatically shut off the tool to prevent overinflation. The M18 Inflator is also resistant to auto shop chemicals.

**Circle 60 on card or click "PTEN e-inquiry" on VehicleServicePros.com**

This product was given to the reviewer free of charge from the manufacturer.



FOR MORE INFORMATION ON THESE PRODUCTS, CLICK ON "PTEN E-INQUIRY" at [VehicleServicePros.com](http://VehicleServicePros.com) OR CIRCLE THE NUMBER ON THE CARD.

# K-Tool International Video Borescope

Reviewed by Matthew Skundrich, owner of Mobile Advanced Diagnostics & Programming in Saint Cloud, Fla.

**Q: How did the tool function as far as saving you time?**

**A:** It gives the ability to see inside and behind objects to have a better idea on what to disassemble. For example, on some Kia/Hyundai blind spots, you need the last two digits of the serial number to see the angle of the radar. The borescope made it much faster to read the sticker with less removal of parts.

On a Nissan, I was able to get a picture of the QR code. Then I had my phone read the QR code from the tool screen, which saved about 20 minutes of taking parts off and on.

**Q: What kind of setup was involved before using the product?**

**A:** The only setup is to install four AA batteries, which are not included.

**Q: How easy was it to use?**

**A:** Just turn it on—the video automatically comes on. The light and zoom are adjustable with the buttons on the bottom half of the tool. Overall, it was simple to use.



**Q: How was the product packaging? Did it come with any accessories?**

**A:** The box is nice. It holds the tool and keeps it safe. Inside the back cover are clips that can go on the camera. I am unsure about the purpose of two of them, but the other one is a 45-degree reflector, which I used a few times.

**Q: Was there a manual included?**

**A:** The tool comes with a basic quick start guide, which includes button functions and standard warnings about proper usage. Although easy to understand, it does lack an explanation of the camera attachments.

**Q: What features did you like?**

**A:** The ability to take pictures is a notable feature. The device requires nothing to store these pictures as it has built-in memory to store up to 30 pictures. It would be useful to recall a picture to show a customer.

Additionally, the digital zoom was effective and the ability to adjust the light through six brightness levels made the tool more usable in some reflective areas.

**Q: Is there any way you could think to improve or add to this tool?**

**A:** Overall, the picture quality is okay. I would suggest developing a way to send pictures or save them externally, for attachment to invoices later.

I would suggest a further explanation of the three camera attachments, either in the instruction manual or a website or QR link to a demonstration.

A storage bag would be advantageous if only to keep dust and dirt off the tool while stored.

**Q: What types of jobs did you use this tool for?**

**A:** Overall, I found it most useful for ADAS and checking to ensure connectors were plugged in. One specific example is a BMW fuse box buried in the back of the glove box. By seeing into the back of the glove box, I more quickly found the necessary number to check the fuse. It sounds like a silly application of the tool, I know, but it sure saves time in hunting for fuses on those cars!

Similarly, the solenoid code and strategic number on Ford transmissions for front wheel drive vehicles can be buried. Using this tool to snap a picture of the code saved considerable time. ☒



**MATTHEW SKUNDRICH** Over the past 15 years, Matthew Skundrich has been diagnosing and fixing automobiles. While repairing vehicles, he also attended Universal Technical Institute, where he finished as student of the course in several courses and maintained perfect attendance. For the past 6 years, he has owned and operated Mobile Advanced Diagnostics and Programming. Providing the local area with dealer services at their door. The services provided to shops are module programming, key cutting, diagnostics, and advanced drivers assistance system calibrations. Additionally, Skundrich has passed both ASE and I-Car certification tests.

This product was given to the reviewer free of charge from the manufacturer.

## PRODUCT DESCRIPTION

The **K-Tool International Video Inspection Borescope**, No. KTIXD3K, is designed to give the user lighted and color visual access into the interior motors, electric components, and hard-to-see areas. It features on-board storage for up to 30 images and a 180-image rotation. The tool is powered by four AA batteries and features a 2.5" LCD screen, 46" probe length, and a fixed 8.5mm forward view imager. Includes a mirror and a magnet/hook.

Circle 61 on card or click "PTEN e-inquiry" on [VehicleServicePros.com](http://VehicleServicePros.com)

# Coast XPH30R Headlamp

Reviewed by Randy Kaiser, technician/service and parts manager, Rost Motor, Inc. in Manson, Iowa.



**Q: How did the tool/equipment function as far as saving you time?**

**A:** This headlamp is a great timesaver. You can slip it on and have it with you whenever

you need extra light to see what you're working on. It's rechargeable, so you don't have to constantly be replacing the batteries.

**Q: How easy was it to use?**

**A:** It's actually very easy to use. There is a switch in the end of the light that turns it on and off and changes the brightness of the light. The lens on the front of the light turns to adjust the width of the beam of light. The body of the light turns in the bracket to adjust how far up or down the light points. If needed, the light can be easily removed from the mounting strap and used as a separate flashlight. The end cap is magnetic, so it can attach to anything metal, and shine where you need it.

**Q: Did it come with any accessories?**

**A:** The flashlight does come with a charging cord. It has one USB-A connector and two USB-C connectors. This makes it very adaptable to charging from a computer or power brick (which is not included). It also means that you can actually charge two devices at once, which is very handy.

**Q: What features did you like?**

**A:** The outer case is a very durable metal. The light beam is adjustable from flood to

spot. The end cap lights up to indicate battery state of charge so that you know when to recharge it. The end cap also unscrews a little way to expose the charging port for the battery, or you can take the battery completely out and charge it. If you need to take the battery out to charge it, but still need to use the light, you can slip in two CR 123 batteries so that you can continue to use it. The light is very bright, but if you need extra light for a short time you can hold in the power button on the end cap, and it goes into "Turbo Mode" and puts out 1,000 lm of light while you hold the button in. This level of light is designed for short-term use, but handy if you need it.

**Q: How could the tool be improved?**

**A:** The power cycle will take some getting used to. When you turn it on, it goes to medium brightness and then cycles through to high and then low. It's just different than most that go from low to high or vice versa.

**Q: Is there any way you could think to improve or add to this tool?**

**A:** It would be nice if the light came with a mounting plate that could be attached to a hard hat for those that are required to wear one. Then they wouldn't have to bother with the mounting strap on their hard hat. ❌



**RANDY KAISER** started working at Rost Motor, Inc. shortly after graduating high school, and he is still working there 48 years later. Through the years, he has been a lube tech, line tech, paint and body tech, parts department head, service manager, and is currently in charge of the parts and service departments. Kaiser is ASE Master Certified and a Ford Master Certified Technician, as well as a Ford certified Service Manager and Service Advisor.

## PRODUCT DESCRIPTION

The four-mode **XPH30R Headlamp** from **Coast** offers up to 1,000 lm on Turbo Mode. Coast's patented Pure Beam technology with a Twist Focus optic enables seamless transitions between the Ultra View flood beam and Bulls-Eye spot beam at up to 165m. This headlamp's dust-resistant and stormproof aluminum body rolls in its bracket for dynamic directional lighting—and can also detach to become a handheld flashlight with a built-in magnetic tail cap and real-time power indicator. Featuring Coast's Rechargeable-Dual Power system for versatility on the job, the headlamp runs on a Coast Zithion-X rechargeable battery (charging cable included) or CR123 lithium batteries (purchased separately).

Circle 62 on card or click "PTEN e-inquiry" on [VehicleServicePros.com](http://VehicleServicePros.com)

This product was given to the reviewer free of charge from the manufacturer.



FOR MORE INFORMATION ON THESE PRODUCTS, CLICK ON "PTEN E-INQUIRY" at [VehicleServicePros.com](http://VehicleServicePros.com) OR CIRCLE THE NUMBER ON THE CARD.

# Bar's Leaks Trans Fix, No. 1415

Reviewed by Lou Fort, lead technician at K.A.R.S. Inc. in Huntingburg, Ind.

**Q: What types of jobs/repairs did you use this tool for?**

**A:** To date, I have used Bar's Leaks Trans Fix during a transmission service on a high mileage Silverado as a precaution/preventative benefit. Next came a 2008 Cruze experiencing mild TCC slip. Most of the testing showed board line code enabling slippage. After adding the Trans Fix the TCC slippage stopped completely in under 50 miles. My last use was on a 1998 Corolla that was experiencing slow engagement, harsh shifts. The Trans Fix didn't 100 percent cure this monster in our follow-up testing but did

greatly improve both the engagement and shift feel. The owner has not called back despite suggesting a second application with full service.

**Q: What kind of setup was involved before using the product?**

**A:** Shake, shake, shake the bottle well. Then find out how much fluid is required for the application.

**Q: How was its packaging? Did it come with any accessories?**

**A:** Trans Fix is in an 11.5 oz. plastic bottle with a spout lid for easier/cleaner pouring.

**Q: Was there a manual included?**

**A:** No manual but usage instructions on the back of the bottle.

**Q: What features did you like?**

**A:** Universal application. The Bar's Leaks Trans Fix works with all transmissions including manual. It may prolong the life of a transmission, and it stops or slows most leaks.

**Q: Is there any way you could think to improve or add to the product?**

**A:** It would be nice to have a measured viewing window on the side of the bottle which would be very helpful when only using a portion of the product.

Also, it doesn't recommend exchanging the fluid at first application, but I believe it should. Out with the old and in with the new. Though, it does recommend changing the fluid and filter if a second application is needed.



**Q: On a scale of 1 to 10, how would you rate this tool overall? Why?**

**A:** I have to award Bar's Leaks a 10 for their Trans Fix offering. It seems to be working as well as, if not better than, the other products we have been using for years. ☒

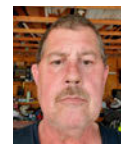

**LOU FORT** has worked in the automotive industry for 47 years and is the lead technician at K.A.R.S. Inc. in Huntingburg, Indiana. Throughout his career, he has worked for Ford, GM, and Chrysler dealerships, but the majority of his time has been spent on the independent side. Fort holds an associate's degree in applied science, along with a year spent studying mechanical engineering.

## PRODUCT DESCRIPTION

**Bar's Leaks Trans Fix, No. 1415**, is an advanced, synthetic-blend treatment for transmission fluid, seals, metal surfaces, bands, and clutch plates. Global domestic/import formulation can be used in all automatics, manuals, CVTs (continuously variable transmissions), and DCTs (dual-clutch transmissions). The formula includes seal conditioners to stop current leaks and prevent future ones; pressure/anti-wear agents to provide better metal-to-metal friction properties to stop slipping, jerking, hard shifting, and shutter/shudder; cleaning detergents; and a performance additive booster that renews worn bands, controls fluid degradation caused by high temperatures, reduces noise, and prolongs the useful life of the transmission.

Circle 63 on card or click "PTEN e-inquiry" on [VehicleServicePros.com](http://VehicleServicePros.com)

This product was given to the reviewer free of charge from the manufacturer.

# Shadow Tool Staging System TSS 6.5

This winner of the 'tool storage' category makes finding your tools super easy.



In each issue of *PTEN*, we will be featuring one of our Innovation Awards winners that scored amongst the highest in the group. This month, we are profiling the Shadow Tool Staging System TSS 6.5, designed to simplify tool selection/return, saving technicians on time and reducing physical motions while making tool inventory control simple. The TSS 6.5 openly presents tools in dedicated positions, allowing visual cues and barrier-free tool selection. The compact system measures 6'5" height by 30" depth by 36" width and sits on 8" wheels. The unit expands with large panels sliding out to 90" in width, exposing shelves, custom accessories, power (110, USB, 12V), battery charging drawer, plus laptop mounting options.

Amanda Silliker, editorial director of *PTEN*, sat down with Kelly Tvrđy Benes, CEO and founder of Shadow Tool Company, to learn more about the Shadow system.

**Amanda Silliker: What makes this product innovative?**

**Kelly Tvrđy Benes:** It's on large casters, so it can be easily moved to the point of work. The mechanic can move Shadow to whatever they want, be it right behind them or right at their side, so that's also uniquely different. Everything's meant to be within hands reach, so when they expand the system and take those panels out, open the enclosure, it's 7.5' feet wide at that point. It offers all the different kinds of tool staging devices, whether it be a hanger or hook or shelves — all different types of holders are available inside the system.

It's meant to be barrier free, with the tools being exposed. It only takes two hand motions for a mechanic to reach a tool versus typically six motions to get a tool either out of a drawer or to put it away. It also provides

complete visual tool access, so it provides cues for selecting tools and returning tools. All these things add up to taking time out of mechanics' day, but the big benefit it also provides is constant visual tool inventory control. Shadow exposes the tools that mechanics are using on a regular basis, so they can keep track of them as they're already doing a very difficult job — it's kind of nice to alleviate the tracking of the tools.

**AS: How did this product come about?**

**KTB:** Shadow came about by addressing a need. A mechanic was getting to be older, and he was kind of tired of taking so many trips over to the wall and where his toolbox was kept, and tracking tools was just a constant battle he had in his in his business, so he developed the original structure for Shadow. I have over 20 years of experience as a co-owner of a business where we designed automated equipment for all different types of manufacturing processes. A lot of that involves watching operators trying to make a smooth inter-

face between the operator and the equipment itself, and I branched off from them and started a company where I consulted for people if they had inventions or ideas and they wanted to take them to market and they needed help with either design or any aspect of patent work, then I would help them.

So I get a call from my brother, and he said, "I have this thing that I think you might want to take to market." I went to his business, and I saw the first rendition of the shadow system. I spent the next six years redesigning and doing a lot of trials and demonstrations and getting a lot of feedback from a lot of mechanics.

**AS: How will Shadow improve the lives of technicians and shop owners?**

**KTB:** It has ergonomic relief. Most of the time savings (30 to 90 minutes a day) is typically based around reducing physical motion, whether it be hand motions or steps, but the reality of it is for the business owner or the mechanic who's paid per job, that 30 to 90 minutes is a huge impact to the mechanic shortage we have in our country right now. Recapturing those labor hours is going to make a significant impact for the business as far as their customers are concerned, getting more work through their shops, and relieving the actual work being done by mechanics who are making everything happen. ☒



AUTEL®



# REMOTE EXPERT

REMOTE SERVICES. EASY COMMUNICATION. INTELLIGENT OPERATION.

## SHOP TECHS REMOTELY CONNECT WITH AN EXPERT MODULE PROGRAMMING

- SAVE TIME & MONEY**
- ONLINE & ALWAYS READY**



WATCH VIDEO NOW



**STEP 1**

Connect to the Vehicle OBDII Port with OBDII Cable

**STEP 2**

MaxiFLASH VCI or VCMI is Connected Via USB to a Tablet

**STEP 3**

Diagnostic Tool: Can Be MS909, MS919 or Ultra

**STEP 4**

Hard-wired Internet Connection Via Cat 5 Cable (Ethernet)

**STEP 5**

Experts Use OEM Hardware & Software Connected to a Programming Converter Box

[CLOUD.AUTEL.COM/EXPERT](https://cloud.autel.com/expert)

Circle 64 on card or click "PTEN e-inquiry" on VehicleServicePros.com

SUPPORT: 1.855.288.3587  
 EMAIL: USSUPPORT@AUTEL.COM | WEB: AUTEL.COM  
 VIEW MARKETING MATERIAL: ISSUU.COM/AUTEL2  
 FOLLOW US @AUTELTOOLS



**AUTEL®**

# CATEGORY SPOTLIGHT

## HAND TOOLS & SPECIALTY TOOLS

Choosing the right hand tool or specialty tool may not be as big of a purchase as a scan tool or diagnostic tool, but it can seem just as challenging. Finding the right one can be difficult. There are many things to consider, such as will it hold up after months of use, does it have non-slip handles, can it fit in small spaces, will it work on heavy duty jobs, etc. Here is a compilation of hand and specialty tools we think is worth checking out.



### INCLUDES DURABLE LATCHING CASE FOR STORAGE

The **Sunex Tools Simple Torque Indexing Torque Wrenches** are designed with a 16-position torque selecting mechanism that adjusts the torque and locks it into place with the simple press and slide of a button, reducing time and allowing users to go from minimum to maximum torque in less than a single rotation. Each torque wrench includes a durable case with latches for safe storage and are pre-calibrated to accuracy  $\pm 4$  percent. The torque wrenches include: 1/4" Dr. 25-250 in-lbs, No. 10250; 3/8" Dr. 5-80 ft-lbs, No. 30580; and 1/2" Dr. 10-160 ft-lbs, No. 21160.

Circle 65 on card or click "PTEN e-inquiry" on [VehicleServicePros.com](http://VehicleServicePros.com)



### SETS IN ALUMINUM AND STEEL MATERIAL RIVETS AND RIVET NUTS

The **Marson HP-4x4 Multiplex Hand Tool** from **Howmet Fastening Systems** features a patented design that allows this single tool to set in a variety of sizes of both aluminum and steel material rivets and rivet nuts. The adjustable jaw system and variety of mandrels, sockets, and nosepieces are easily changed to set blind rivets up to 3/16" diameter, rivet nuts up to 1/4- 20 size, MET series external thread stud rivet bolts up to 1/4-20, MQN jack nuts, and MXN series rivet nuts up to 1/4-20. Available as a kit, No. M39410, which comes in a molded plastic case with a small plastic box to hold parts and an adjustable jaw system.

Circle 66 on card or click "PTEN e-inquiry" on [VehicleServicePros.com](http://VehicleServicePros.com)



### WORKS WITH LEFT AND RIGHT SIDE CALIPERS

The **Lock Technology Bendix/Knorr-Bremse Air Disc Brake Pad Retainer Tool**, No. LT891, is designed to provide a safe and easy way to remove the pad retainer when servicing Bendix/Knorr-Bremse air disc brakes. The patent-pending tool works with left and right side calipers, and can work with or without the caliper shield. It features an easy grip handle and is heat treated for strength and durability.

Circle 68 on card or click "PTEN e-inquiry" on [VehicleServicePros.com](http://VehicleServicePros.com)



### STEEL CONSTRUCTION WITH TEXTURED GRIP

The **Cal-Van Tools Adjustable Indexing Trim Clip Pliers**, No. 54, are designed to remove plastic anchors with center pins without causing damage to the pin or the anchor with one-handed operation. Its adjustable head allows access to hard-to-reach areas. The pliers are made from steel construction with a double-dipped textured grip.

Circle 67 on card or click "PTEN e-inquiry" on [VehicleServicePros.com](http://VehicleServicePros.com)



### AUTOMATICALLY ADJUSTS TO FIT BOLTS OF 3/8" TO 11/16"

The **Anglo American Tools NES5 Tight Space Thread Restorer** is a universal, external thread repair tool. The high speed stainless steel cutter floats in its position to enable the tool to smoothly repair inch or metric, right or left handed, coarse or fine threads. The tool automatically adjusts to fit bolts of 3/8" to 11/16" (10mm to 18mm) and requires only 5/8" clearance around the bolt.

Circle 69 on card or click "PTEN e-inquiry" on [VehicleServicePros.com](http://VehicleServicePros.com)



FOR MORE INFORMATION ON THESE PRODUCTS,  
CLICK ON "PTEN E-INQUIRY"  
at [VehicleServicePros.com](http://VehicleServicePros.com)  
OR CIRCLE THE NUMBER ON THE CARD.



### ENHANCED DESIGN FOR SLIMMER PROFILE

The **Cementex Updated Double-Insulated Wrenches** now feature a continuous outer layer of orange insulation to provide a smooth transition between the dual-layer and single-layer portions of each tool. The enhanced design enables the work end of the open-end, box-end, and geared wrenches to be slimmer. According to the company, the insulation is guaranteed to pass a 10,000 VAC proof test in accordance with applicable U.S. and international standards.

Circle 70 on card or click "PTEN e-inquiry" on [VehicleServicePros.com](http://VehicleServicePros.com)



### EASES STRAIN ON HANDS

The **Olsa Tools Ratcheting Wire Crimper** eases strain on hands thanks to large, non-slip handles that are designed to ensure a strong and comfortable grip. The ratcheting action allows the user to pause mid-crimp to get a better grip and will release automatically once the crimp is complete. It also conveniently enables users to secure a wire connector in the jaw before inserting the stripped wire into the barrel. Works with color-coded red, blue, and yellow terminals for 22 - 10 AWG wires.

Circle 71 on card or click "PTEN e-inquiry" on [VehicleServicePros.com](http://VehicleServicePros.com)

## CATEGORY SPOTLIGHT



Hand Tools & Specialty Tools



### REMOVES IRREGULARITIES IN FLARED TUBING

The **Koul Tools Surseat P51B Flare Lapping Tool** is designed to remove irregularities in flared tubing, leaving an ideal sealing surface. The tool features an easy-to-use clip mechanism for the interchangeable 37-degree and 45-degree lap heads to polish steel, stainless steel, and copper tubing. The shape and size of the tool make it easier to work in tight spaces, and the lock-spring system secures the tube seamlessly in the tool's cavity.

Circle 72 on card or click "PTEN e-inquiry" on [VehicleServicePros.com](http://VehicleServicePros.com)

# AIRCAT

PNEUMATIC TOOLS®

# 6355



## Reciprocating Air Saw

- 🔧 5,000 SPM (strokes per minute)
- 🔧 Dual-Speed design for control
- 🔧 Capable of cutting 1/4" thick steel and steel pipe up to 3"
- 🔧 Quick change blade design retainer for quick and easy blade changes
- 🔧 Accepts various types of reciprocating saw blades



[AIRCAT.com](http://AIRCAT.com) | (888) 4-AIRCAT

Circle 73 on card or click "PTEN e-inquiry" on [VehicleServicePros.com](http://VehicleServicePros.com)

**FEATURES ALL METAL CONSTRUCTION ADAPTERS**

The **CTA Manufacturing 11-pc Pro-Series Brake Bleeding Adapter Set**, No. 3930, features all metal construction adapters. It services many late model domestic, Euro, and Asian vehicles. Most of the adapters have a 90-degree swivel connection fitting for when space is limited. The set is designed to work with CTA's Pressure Bleeder Tank, No. 7015, but not limited to. The adapters come equipped with standard European (Nitto) fittings, but it also includes a standard National (Milton) fitting adapter for use with other pressure bleeder tanks. The set includes nine master cylinder adapters, one quick coupler, and one Milton adapter in a blow molded case with flexible EVA storage insert.

Circle 74 on card or click "PTEN e-inquiry" on VehicleServicePros.com



FOR MORE INFORMATION ON THESE PRODUCTS, CLICK ON "PTEN E-INQUIRY" at VehicleServicePros.com OR CIRCLE THE NUMBER ON THE CARD.



**OFFERS SELF-LOCKING FEATURE**

The **Lang Tools 3-pc Hose Pinch Pliers Set**, No. 1500, is designed with a self-locking feature that holds after pressure is applied. Simply pull the handles apart to release pressure. The set includes three sizes to accommodate various hose ranges. The small pliers have an overall closed length of 6", while the medium is 9-3/4", and the large is 13". The pliers are made from high-carbon, heat-treated, steel components, and are plated with black oxide coating and an oil dip for rust prevention. The vinyl hand grips allow for comfort and a secure grasp. The patented offset design allows access in hard-to-reach areas. They are made in the U.S.A.

Circle 75 on card or click "PTEN e-inquiry" on VehicleServicePros.com



**GPR-Pro™**  
Glue Pull Repair System

**PROFESSIONAL KIT INCLUDES:**

- ✓ Minor dent tabs and heavy damage ring tabs
- ✓ Lift and lateral pull strips allow for complex repairs
- ✓ Opaque Pro glue is ideal for all glue pull applications



[HSAUTOSHOT.COM](http://HSAUTOSHOT.COM)



FOLLOW US @HSAUTOSHOT

Circle 76 on card or click "PTEN e-inquiry" on VehicleServicePros.com



**FEATURES A 3,500 LB IMPACT STRIKING FORCE**

The **Spring Tools 5-pc Master Mechanics Set**, No. 50X08 is designed for mechanical and metalworking applications. The set includes a combination prick and center punch, a self-centering center punch, a high speed steel center punch, a cold chisel, and a ping hammer. The tools feature a 3,500 lb impact striking force and are ideal in tight spaces. Their patented design is safe and easy to use, and won't damage or scratch metal or aluminum surfaces, the company says. The set is made in the U.S.A.

Circle 77 on card or click "PTEN e-inquiry" on VehicleServicePros.com

# How do *you* plan to service EV battery packs?

The BendPak EV2400SL is a push-around full-rise scissor lift table that is perfectly suited for EV battery pack replacement. With its compact design, this space-saving scissor lift can be easily transported anywhere in the workplace, making it ideal for multi-bay facilities or workplaces with confined areas. To learn more visit [www.bendpak.com/EVLIFT](http://www.bendpak.com/EVLIFT).

**NEW**

40"

60"



Full-Length  
Utility Trays

Twin Hydraulic  
Cylinders

12-Volt Deep  
Cycle Battery

Oversized  
Urethane Casters



Hand Pendant Control



Optional Adapters



Battery-Powered Mobility

BENDPAK MODEL  
EV2400SL  
SPECIALTY LIFT

1-800-253-2363 ■ [www.bendpak.com](http://www.bendpak.com)

**BP BendPak**

© 2022 BendPak Inc. All rights reserved.

Circle 78 on card or click "PTEN e-inquiry" on [VehicleServicePros.com](http://VehicleServicePros.com)

# 3-PIECE EXTRA LONG PIN PUNCH SET WITH HANDLE AND STRIKING CAP



**856-3ST**

Also available individually.



16" LENGTH ALLOWS  
INCREASED ACCESS FOR HARD  
TO REACH AREAS

SET CONSISTS OF PUNCHES  
WITH 1/4", 5/16" AND 3/8"  
TIP DIAMETERS

ERGONOMIC HANDLE WITH  
STRIKING CAP FOR SECURE GRIP  
WHILE STRIKING

**LANG**  
TOOLS  
Professional Tools For 4 Generations™

[WWW.LANGTOOLS.COM](http://WWW.LANGTOOLS.COM)

Circle 79 on card or click "PTEN e-inquiry" on  
VehicleServicePros.com



## CATEGORY SPOTLIGHT

Hand Tools & Specialty Tools

### STRAIGHTENS 3/16" AND 1/4" TUBING

The **S.U.R.&R. Handheld Tubing Straightener**, No. TS224, is designed to straighten 3/16" and 1/4" tubing. It can be used on aluminum, copper-nickel, and steel lines. It straightens tubing with the flip of a convenient thumb-sized selector, then slides the tubing through the straightener to eliminate curves or bends. It's ideal for creating long and consistently straight lines from bulk tubing coils. The TS224 can be used in a vise or on the vehicle thanks to its compact design that makes the tool easy to grip and control. The TS224 also works well with S.U.R.&R. UltraBEND flexible brake line tubing and Max Flex Alloy tubing coils or bundles.

Circle 80 on card or click "PTEN e-inquiry" on VehicleServicePros.com



### OVER 100 STORAGE COMPARTMENTS

The **Wiha Tools 93-pc XXL3 PRO Tool Set** comes in the XXL3 Rolling Tool Case. The tool case is made from heavy duty construction, has all-terrain wheels, a 42" extendable handle, fold-out legs, and a gas-strut-propper lid. Tools in the set include 5-pc PicoFinish Precision Screwdriver set, SoftFinish Slotted Screwdriver 6.5mm, SoftFinish Square Screwdriver #2, SoftFinish X Heavy Duty Slotted 8mm, SoftFinish X Heavy Duty Slotted 12mm, SoftFinish X Heavy Duty Philips #2, 14inOne SoftFinish Stubby Multi-Bit Driver, SoftFinish 11inOne Multi-Driver, Classic Grip Long Nose Pliers 8", Classic Grip BiCut SuperCut 8", Classic Grip Auto Pliers 10", Classic Grip End Cutting Nippers 8", 9-pc MagicRing Ball End Hex L-Key Set (metric), 13-pc MagicRing Ball End Hex L-Key Set (inch), 6-pc Color Coded Magnetic Nut Setter Set, and 35-pc 1/4" Ratchet and Bit Set.

Circle 81 on card or click "PTEN e-inquiry" on VehicleServicePros.com



### HAS 10 ADJUSTABLE POSITIONS

The **KNIPEX 4" Pliers Wrench XS**, No. 86 04 100, features 10 adjustable positions and one-handed quick adjustments, up to 3/4" gripping capacity. Texturized handles allow for ideal gripping, holding, pressing, and bending applications. The parallel jaws evenly distribute force for a secure grip, the smooth jaws will not mar surface finish, and the pinch guard prevents operators' fingers from being pinched. Additionally, it offers a box-joint design for higher stability, and the compact design and slim head allows easy access to confined areas.

Circle 82 on card or click "PTEN e-inquiry" on VehicleServicePros.com

**CUSTOMER REVIEW:**  
"As expected, KNIPEX uses high-quality materials. They're easily adjustable and the jaws remain parallel when opening and closing. They are the perfect size for hard-to-reach fasteners."

# DEVELOP

TUESDAY, NOVEMBER 1 - THURSDAY, NOVEMBER 3, 2022

# POWERFUL SKILLS

THE VENETIAN EXPO | LAS VEGAS, NV | #AAPEX22

**aapex**  
*ahead of the curve*

Your customers depend on you to keep vehicles running smoothly. And you depend on your industry event to keep you in the know about the tools, training, products, and technology to help you do that. Make plans to join your community. With a robust marketplace and experiential learning opportunities, 2022's event will give you that traction you need in a changing market with new and renewed connections, current insights, training, and a profitable future.

**LEARN MORE** > [aapexshow.com](https://aapexshow.com)



Circle 83 on card or click "PTEN e-inquiry" on [VehicleServicePros.com](https://VehicleServicePros.com)

★ 2022 ★  
GREAT PRIZE  
**GIVEAWAY**



**EVERYONE'S A WINNER!**

Introduce a New Revenue Stream With Our Key Making System



Package includes everything you need to begin making car keys!



FOR MORE INFO  
**SCAN  
HERE**

Circle 84 on card or click "PTEN e-inquiry" on VehicleServicePros.com

**✂ CATEGORY SPOTLIGHT**

Hand Tools & Specialty Tools



**ALLOWS ACCESS INTO CONFINED WORK SPACES**

The **Titan Professional Tools Stubby Adjustable Wrench**, No. 12138, allows access into confined work spaces where standard length adjustable wrenches won't fit, the company says. Features include an extra-wide 1-1/8" jaw capacity, 15-degree angled offset head, easy-to-read quick fit size range indicators with standard and metric scales, precision machined jaws for smooth operation, and a comfortable non-slip dipped grip to reduce hand fatigue. The drop forged and heat-treated carbon steel industrial black phosphate finish resists corrosion.

Circle 85 on card or click "PTEN e-inquiry" on VehicleServicePros.com



**AVAILABLE IN LONG NOSE, DIAGONAL NOSE, AND BENT NOSE STYLES**

The **Century Drill & Tool Spring Loaded Pliers** are available in long nose, diagonal nose, and bent nose styles. The spring loaded design makes for easy use. The pliers are made from chrome vanadium steel for strength and durability, and feature comfort grip handles for additional grip to maximize force with less fatigue. The needle nose and bent nose pliers provide ideal control and grip in small or hard-to-reach areas, while the diagonal nose pliers are ideal for cutting wire. The long nose and diagonal nose pliers are 4-1/2" in length. The bent nose pliers are 5" in length.

Circle 87 on card or click "PTEN e-inquiry" on VehicleServicePros.com



**REMOVES BROKEN EXHAUST MANIFOLD BOLTS ON DODGE/JEEP V6 3.8L ENGINES**

The **ProMAXX Kaiden Exhaust Manifold Repair Kit** is designed to help technicians easily remove broken exhaust manifold bolts on Dodge/Jeep V6 3.8L engines. The kit is designed for Jeep Wrangler, Chrysler Town and Country, Pacifica, and any other vehicles equipped with the 3.8L engine. In addition to precision-engineered guide plates, ProMAXX Tool's exclusive screw-in bushings provide exact alignment with the 3.8L engine cylinder head. Kaiden incorporates splined, slip-nut-styled, non-deforming extractors that are utilized in both a clockwise and counter-clockwise direction. This unlocks the broken bolt remnant without pinching it in the cylinder head.

Circle 86 on card or click "PTEN e-inquiry" on VehicleServicePros.com

**FITS STRUT RODS UP TO 9/16" IN DIAMETER**



The **Thexton Magnetic Strut Rod Lock**, No. 939, is an upgrade to the company's Hood/Tailgate Prop, No. 430. It fits strut rods up to 9/16" in diameter and a magnet has been added in the base to now allow for one-handed applications. The tool securely attaches to a strut rod and holds hoods, trunks, or tailgates in place. It's made in the U.S.A. from lightweight aluminum and the soft load bolt will not damage the strut rod, the company says.

Circle 88 on card or click "PTEN e-inquiry" on VehicleServicePros.com





FOR MORE INFORMATION ON THESE PRODUCTS,  
CLICK ON "PTEN E-INQUIRY"  
at [VehicleServicePros.com](http://VehicleServicePros.com)  
OR CIRCLE THE NUMBER ON THE CARD.

## CATEGORY SPOTLIGHT



Hand Tools & Specialty Tools



### ACCOMMODATES AWG20 TO AWG12

The **OTC Angled Wire Stripping Tool**, No. 5950D, is designed with the stripping dies on the angled tip, above the pivot point, to give users the right angle to neatly strip or cut wires in tough-to-reach places. The proprietary design allows for a better view for those tasks done in tight spaces, ideal for wiring service under dash, inside panels, and in the engine compartment. The tool accommodates AWG20 to AWG12.

Circle 89 on card or click "PTEN e-inquiry" on [VehicleServicePros.com](http://VehicleServicePros.com)



Watch this product in action here:  
[VehicleServicePros.com/21276912](http://VehicleServicePros.com/21276912)



### 15-DEGREE OFFSET HEAD

The **Platinum Tech 7-pc SAE Flare Nut Wrench Set**, No. PLT-99700, is ideal for use on hex nuts made of softer materials. Its flare nut design allows for a better grip without slipping and the opening in the head gives greater access to fittings used on tubing. The wrenches have a 15-degree offset head and are made from chrome vanadium steel for strength and durability. They also have a full polish chrome finish for corrosion resistance and meet or exceed ANSI standards.

Circle 90 on card or click "PTEN e-inquiry" on [VehicleServicePros.com](http://VehicleServicePros.com)



### THREADLESS FOR DURABILITY

The **Trusty-Cook 47 oz. Ball Peen Dead Blow**, No. TC47BP, is ideal for machinists, mechanics, toolmakers, and metal stampers. The steel-faced hammer is threadless for durability. The steel-faced dead blow ball peen weighs 2.9 lbs, and its dimensions are 4.82" width by 1.75" depth" by 13.625" height.

Circle 91 on card or click "PTEN e-inquiry" on [VehicleServicePros.com](http://VehicleServicePros.com)

## TOSS YOUR TORCH



LUG NUTS



STRUTS

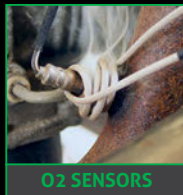

O2 SENSORS

### Mini-Ductor® VENOM® HP



The Venom HP is the highest powered Mini-Ductor handheld induction heater available at **1800** watts of power. Allows users to heat metal components faster than ever before! Manufactured with genuine OEM parts. *More precise, safe and reliable than a torch.*

Available through your local tool distributor.



**INDUCTION INNOVATIONS**  
[www.theinductor.com](http://www.theinductor.com)  
877-688-9633



Follow Us on Social Media:



Circle 92 on card or click "PTEN e-inquiry" on [VehicleServicePros.com](http://VehicleServicePros.com)

MADE IN USA



Visit our  
SITE:



[KenTool.com](http://KenTool.com)



T45AC™ 34645C TIRE IRON  
T45AS 34649 TIRE IRON  
T45A 34645 TIRE IRON

THE  
NAME  
YOU  
TRUST,  
THE  
SHAPE  
YOU KNOW

1-888-536-8665

768 E. North Street  
P.O. Box 9320  
Akron, Ohio 44305  
Fax: 800-872-4929  
Phone: 330-535-7177  
Fax: 330-535-1345

E-mail: [sales@kentool.com](mailto:sales@kentool.com)

©2022 Ken-Tool. All Rights Reserved. KT082022

Circle 93 on card or click "PTEN e-inquiry" on [VehicleServicePros.com](http://VehicleServicePros.com)



## CATEGORY SPOTLIGHT

Hand Tools & Specialty Tools



### ALLOWS ACCESS IN TIGHT AREAS FROM ANY ANGLE

The **Cornwell Tools 120 Tooth Flex Head Ratchet**, No. JRF120LHB, features a 120-tooth ratcheting design that provides a 3-degree handle swing. Its 180-degree, seven-position flex head allows access in tight areas from any angle and its thin head design enables for close clearance applications. The high-polished, chrome-plated finish provides corrosion protection. The ratchet has a 3/8" drive, overall length of 12-3/8", head thickness of 19/32", and a head width of 1-3/8".

Circle 94 on card or click "PTEN e-inquiry" on [VehicleServicePros.com](http://VehicleServicePros.com)

**“ The more teeth you have, the smaller the angle you have to turn a ratchet for it to engage and the user can get into tighter places. With 90, 80, 70 teeth, there isn't enough room for you to swing the ratchet for it to click to be able to rotate the bolt. This one has a three-degree swing which is unbelievably small. ”**  
—Don Russell, director of marketing, Cornwell



### ELIMINATES AIRLOCKS IN COOLING SYSTEM

The **Carlyle Tools Cooling System Refilling Gun**, No. SER 70880, is designed to reduce filling time and eliminates airlocks in the cooling system. It uses deep vacuum technology to eliminate the need for system bleeding. It has a universal attachment to most radiator and header tanks and includes small and large rubber cones to fit both passenger and commercial vehicles. No additional adapters are needed. It also features an integrated vacuum gauge that automatically tests the cooling system for leaks, a built-in filling tap and vacuum check valve to remove the need for interchanging hoses and eliminates coolant spills and waste, and a quick-release air supply locking trigger for easy use.

Circle 95 on card or click "PTEN e-inquiry" on [VehicleServicePros.com](http://VehicleServicePros.com)



### CAN BE USED WITH MOST CLASS 6 TO CLASS 8 TRUCKS

The **ESCO Sheppard M100 Pitman Arm Puller**, No. 40311, is designed to safely and easily remove pitman arms from the output shaft on Sheppard M100 gearboxes. It can be used with most Class 6 to Class 8 transportation trucks and equipment and eliminates dangerous hammering and cutting torch methods, the company says. It's made from heavy duty constructed casted steel and can be used with an impact gun up to 3/4".

Circle 97 on card or click "PTEN e-inquiry" on [VehicleServicePros.com](http://VehicleServicePros.com)



Over 50 years of OEM quality at aftermarket prices!



Scan for our catalog



#### Master Back Probe Kit

Cat. No. 23550

- Use to back probe harness connectors, fuel injectors and automotive sensors
- Compatible with standard 4mm plug
- Comes with NEW Curved Probe lead wires and Flex Back Probes



#### 20 Piece Back Probe Kit

Cat. No. 23500

- Use to back probe harness connectors, fuel injectors and automotive sensors
- 12" extension leads permit testing in recessed areas
- Color coded for easy identification



#### Quick Change Ratcheting Crimping Kit

Cat. No. 18980

- Includes 9 Die Sets
- Quickly and easily change Die Sets with the press of a lever
- Crimps insulated, uninsulated, open barrel, and many other popular automotive terminals

[www.toolaid.com](http://www.toolaid.com)

Circle 96 on card or click "PTEN e-inquiry" on [VehicleServicePros.com](http://VehicleServicePros.com)

# 2022 TRAINING EVENT

**MOTOR AGE**  
TRAINING

**PTEN**  
PROFESSIONAL TOOL & EQUIPMENT NEWS

**MOTOR AGE**

**ABRN**  
AUTO BODY REPAIR NETWORK

**VEHICLESERVICEPROS**.COM

OCT. 15, 2022 - EMBASSY SUITES - ROSEMONT, ILLINOIS

# ACCELERATE

A MOTOR AGE TRAINING EVENT

## 2022 TRAINERS



### SCOTT BROWN

Session: ENGINE CONTROLLER CALIBRATIONS:  
Developing New Perspectives for Drivability Technicians



### BRANDON STECKLER

Session: SCAN TOOL ANALYSIS 101:  
Gaining Diagnostic Direction From The Driver's Seat



### PETE MEIER

Session: ELECTRICAL CHALLENGES:  
Three Steps to Successful Electrical Troubleshooting



### G. JERRY TRUGLIA

Session: HYBRIDS & EVS: Understanding  
and Diagnosing Hybrid / Electric Vehicles

REGISTER TODAY AT [WWW.ACCELERATE-CONFERENCE.COM](http://WWW.ACCELERATE-CONFERENCE.COM)

SPONSORED BY

**AUTEL**

AutoLeap

**Milwaukee**



## CATEGORY SPOTLIGHT

Hand Tools & Specialty Tools

### INCLUDES SIX LOCKING PLIERS AND CLAMPS

The **Malco Products Eagle Grip Locking Tools** are forged from premium American steel to deliver strong and reliable performance. Made in the U.S.A., the tools were designed to meet the rigorous demands of professional users. The line currently consists of six locking pliers and clamps for use in sheet metal, automotive, welding, and agriculture applications. The locking pliers include 7" and 10" straight jaw locking pliers and 7" and 10" curved jaw locking pliers with wire cutters. The clamps include 11" locking C-clamps and 11" locking C-clamps with swivel pads.



Circle 98 on card or click "PTEN e-inquiry" on [VehicleServicePros.com](http://VehicleServicePros.com)



FOR MORE INFORMATION ON THESE PRODUCTS, CLICK ON "PTEN E-INQUIRY" at [VehicleServicePros.com](http://VehicleServicePros.com) OR CIRCLE THE NUMBER ON THE CARD.



### MEETS ASME B107.300 SPECIFICATIONS WITH AN ACCURACY OF +/- 4 PERCENT

The **Mac Tools 1/2" Drive 50-250 ft-lb Direct Torque Wrench**, No. TWV250DR, meets ASME B107.300 specifications with an accuracy of +/- 4 percent. The torque wrench features a direct read scale for easy read-out. Using a magnifier and number scale help reduce errors and improve efficiency when setting a required torque. The product also features a sealed body rated at IP54 to help eliminate dust ingress for durability and is offered in a 1/2" drive 30-150 ft-lb and 3/8" drive 7-40 ft-lb version.

Circle 99 on card or click "PTEN e-inquiry" on [VehicleServicePros.com](http://VehicleServicePros.com)

**ULINE**  
SHIPPING SUPPLY SPECIALISTS

DYNEEMA®  
**TOUGH GLOVES**

WAREHOUSE  
LATEX  
NITRILE

ORDER BY 6 PM FOR SAME DAY SHIPPING  
**COMPLETE CATALOG 1-800-295-5510**

Circle 100 on card or click "PTEN e-inquiry" on [VehicleServicePros.com](http://VehicleServicePros.com)

### EACH TOOL MEASURES 5" IN LENGTH

The **Mayhew Tools 4-pc Micro Hook and Pick Set**, No. 31098, includes a straight pick, 90-degree bent pick, dual angle pick, and a micro hook. Made in the U.S.A. and backed by a lifetime warranty, the hook and picks measure 5" in length, making them ideal for easy access into tight spaces and/or providing leverage in close quarters. Each tool features a handle made from high-tensile strength Nylon 6 material, enabling them to withstand abrasions and damage. With their small size, the tools can easily maneuver around obstacles and retrieve various components, such as hoses, moldings, clips, clamps, seals, O-rings, cotter pins, and gaskets.

Circle 102 on card or click "PTEN e-inquiry" on [VehicleServicePros.com](http://VehicleServicePros.com)





**REPLACES BRAKE SHOES ON HEAVY DUTY TRACTOR AND TRAILER S-CAM BRAKES**

The **Lisle Corporation Brake Spring Bar**, No. 40030, replaces brake shoes on heavy duty tractor and trailer S-Cam brakes. To remove the spring, slip the hook into the retaining spring loop and press down against the axle. The Brake Spring Bar levers action against the axle to eliminate the need for wrenches, pry bars, and screwdrivers. The tool is 18" long with a molded handle for comfort and has a black oxide finish.

Circle 103 on card or click "PTEN e-inquiry" on VehicleServicePros.com



**CLEANS HARD-TO-DROP FUEL TANK**

**Delphi Technologies Fuel Tank Cleaning Tool**, No. FC02, is designed to clean a hard-to-drop fuel tank before installing a new pump module. Installing a new fuel pump in an old fuel tank without a way to effectively clean that tank presents a challenge for technicians who want to avoid premature wear or failure of the new pump from debris and contamination, the company says. The FC02 is an easy and quick solution that allows technicians to maximize customer satisfaction and revenue opportunities from high quality fuel maintenance services.

Circle 104 on card or click "PTEN e-inquiry" on VehicleServicePros.com



**HIGH-STRENGTH FIBERGLASS HANDLE**

The **ATD Tools 2-pc Rubber Mallet Set**, No. ATD-4020, features a soft yet durable head that is designed to deliver a blow with minimum marring or surface damage. Its high-strength fiberglass handle absorbs vibration while its non-slip rubber grip is integrated into the handle.

Circle 105 on card or click "PTEN e-inquiry" on VehicleServicePros.com



**Dependable. Safe. Long Lasting.**



Experience The Gray Difference

At Gray Manufacturing, your ability to do business is our top concern. Our vertically integrated manufacturing process means that every component of our quality truck lifts is manufactured and built by Gray. When you need a repair or replacement part, you make one phone call. We specialize in service after the sale and are invested in your success as a service and repair facility.



- Clutch Jacks
- Fork Lift Jacks
- Engine Stands
- Miscellaneous Equipment
- Floor Service Jacks
- Mobile Column Lifts
- Fluid Handlers
- And more!



1.800.821.7320 • GRAYUSA.COM





## CATEGORY SPOTLIGHT

Hand Tools & Specialty Tools



### REMOVES HOSES, MOLDINGS, CLIPS, O-RINGS, AND MORE

The **OEMTOOLS 5-pc Hose Removal Set**, No. 26519, contains long and short, standard, and offset hooks. They can be used to remove hoses, moldings, clips, clamps, seals, O-rings, cotter pins, gaskets, etc. The handles are made of dual durometer material for comfort and grip. The steel rods are heat-treated for strength and plated for durability. The full-sized, long-reach picks are ideal for assembly, repair and removal of small parts, and separating wires.

Circle 107 on card or click "PTEN e-inquiry" on [VehicleServicePros.com](http://VehicleServicePros.com)



### FITS SECURELY IN PALM OF HAND

The **VIM Tools Button Clip Disconnect Tool with Swivel Head**, No. BCT1, fits securely and ergonomically in the palm of the user's hand, and is used to quickly disconnect fuel, EVAP, and DEF fittings with button-type connectors. It also works with most electrical connections on Asian vehicles. The BCT1 is designed to eliminate the need for bulky pliers and cables that require both hands to remove button-type connectors. Spring-loaded pivoting jaws and 180-degree swivel head with knurled finger rests for extra grip make it easier to hold onto and maneuver. The BCT1 non-slip grip is made up of double dipped PVC.

Circle 108 on card or click "PTEN e-inquiry" on [VehicleServicePros.com](http://VehicleServicePros.com)



### RATCHET HEAD MAINTAINS THE DESIRED POSITION

The **Matco Tools 3/8" Drive 9" Eighty8 Tooth Long Locking Flex Ratchet** features a slim profile to allow access in tight areas and produces a swing arc just over 4 degrees, allowing fast work in compact spaces. The 9-position locking flex head ensures the ratchet head maintains the desired position, regardless of size or applied load. Its recessed shift lever prevents accidental shifting while its positive stop feature will prevent any over travel or lock up while switching. Available in standard chrome, or with an ergonomic comfort handle that comes in blue, green, orange, and red, which helps reduce fatigue. Made in the U.S.A.

Circle 109 on card or click "PTEN e-inquiry" on [VehicleServicePros.com](http://VehicleServicePros.com)

**UP TO 80% SLOWER RETRACTION**

**INNOVATING SAFETY**



**COXREELS®**

**EZ-COIL PATENTED REWIND SYSTEM SAFEST REELS IN THE INDUSTRY.**

**DURABLE. RELIABLE. HOSE, CORD, & CABLE PRO GRADE REELS**

- ✓ Eliminate dangerous whipping hazards.
- ✓ Requires no external power source.
- ✓ Wide array of reel models & options to increase worksite efficiency & safety.

**SOLUTIONS FOR:**  
WATER | AIR | POWER | HYDRAULIC | PNEUMATIC | VACUUM | WELDING  
AND MORE

**MADE IN THE USA SINCE 1923**

[www.COXREELS.com](http://www.COXREELS.com)

Circle 110 on card or click "PTEN e-inquiry" on [VehicleServicePros.com](http://VehicleServicePros.com)  
54 PTEN © SEPTEMBER 2022 © [www.VehicleServicePros.com](http://www.VehicleServicePros.com)

**New Relay Buddy!**

**194 Super Relay Buddy®**

- Full 7 Amp load during the test
- Relay voltage drop monitored
- **Ten second test!**
- Test results displayed as red, green or yellow for caution



- Tests 7 different 12 volt relays
- More effective test finds intermittently bad relays

**195 Super Relay Buddy® Pro Kit**

- Kit includes adapters for expanded test coverage - 10 different 12V relays



**Call 800-227-1603 for more info. - [www.esitest.com](http://www.esitest.com)**

Circle 111 on card or click "PTEN e-inquiry" on [VehicleServicePros.com](http://VehicleServicePros.com)

## CATEGORY SPOTLIGHT



Hand Tools & Specialty Tools



### PROVIDES NEARLY 18-TONS OF FORCE

The **Schley Products High Pressure Ball Joint Press**, No. 18100, is designed to remove and reinstall most press-in type ball joints equipped on late model Ford and Dodge full-size pickup trucks, 4500/5500 series GM trucks, and other vehicles equipped with steering knuckles and ball joints. The 18100 utilizes patented technology that incorporates tenacious 2:1 pivoting action with durable forged alloy steel construction, which increases the effective pressing force of the tool and lowers the operating weight down to approximately 25 lbs. It provides nearly 18 tons of force and plenty of clearance between the frame, pivot link, and cups, enabling the tech to remove and install ball joints while the vehicle is on a lift or alignment rack.

Circle 112 on card or click "PTEN e-inquiry" on [VehicleServicePros.com](http://VehicleServicePros.com)



### THICK ERGONOMICALLY DESIGNED HANDLES FOR SECURE GRIP

The **Performance Tool 3-pc Pry Bar Set with Strike Cap**, No. W2023, includes 12", 17", and 24" sizes. The tools feature thick ergonomically designed handles for comfort and secure grip and are made of high carbon steel for strength and durability. The capped ends allow users to strike with a hammer without damaging the handle. Curved blade ends and long shafts provide ideal delivery of prying power. The bars are fully hardened and tempered, then black powder coated to prevent rust.

Circle 114 on card or click "PTEN e-inquiry" on [VehicleServicePros.com](http://VehicleServicePros.com)

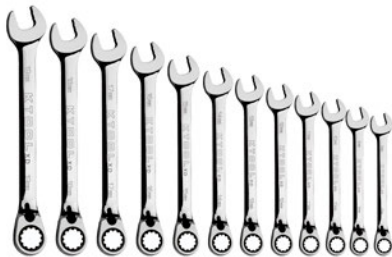

### CAN REMOVE AND TIGHTEN NUTS AND FASTENERS

The **K-Tool International 12-pc Metric 120-Tooth Reversible Combination Wrench Set** is a set of high-quality, non-slip, open-end wrenches that can remove and tighten nuts and fasteners. Designed with a patented spherical box-end, the wrenches can work for different fastener types. Featuring a 3-degree swing movement, the wrenches work great in tight areas and allow for fast and easy ratcheting direction changes with the reversing lever. The 15-degree head offset provides knuckle clearance and has an innovative design that keeps the professional technician in mind.

Circle 113 on card or click "PTEN e-inquiry" on [VehicleServicePros.com](http://VehicleServicePros.com)

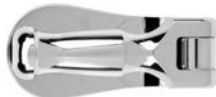

### FOR USE IN MINIMAL ACCESS SPACES

The **Tekton 3/8" Drive Folding Ratchets** are designed for use in minimal access spaces, providing low leverage and high speed. The patent-pending ratchets use the company's 90-tooth ratchet mechanism in the ultra-compact 3/8" drive head. They fully extend into a small offset ratchet. In partially folded positions, the handle gets out of the way for greater access and in the fully closed position, they are an ergonomic palm ratchet. The joint is non-locking for continuous range and stiff so that it doesn't flop around. The ratchets are available in quick-release and non-quick release models.

Circle 115 on card or click "PTEN e-inquiry" on [VehicleServicePros.com](http://VehicleServicePros.com)



THE INDUSTRY LEADER

SAVE  
\$100 - \$250

## New Power Stroke Combo Kits



Power Stroke Alpha  
**PMXPST500PRO**

### Make These Repairs

- 6.7L EGR Mounting Tube Bolts
- Fuel Injector Bolts
- Hold Down Bolts
- Broken Exhaust Manifold Bolts
- Pull Fuel Injectors

CALL PROMAXX® TOOL  
WE LOVE TALKING TO  
TECHNICIANS!

724-941-0941

Check Out  
Power Stroke  
Combo Kits



[promaxxtool.com](http://promaxxtool.com)

Circle 116 on card or click "PTEN e-inquiry" on [VehicleServicePros.com](http://VehicleServicePros.com)

Every Toolbox Needs...



## WALTON™ Tap Extractors & Tap Extensions

### TAP EXTRACTORS

- Remove broken taps simply and safely – no drilling, lasers, damaged threads, scrapped parts or repair inserts.
- Available in every tap size, both inch and metric.

### TAP EXTENSIONS

- Extend the reach of regular-length taps and allow tapping in deep holes and awkward locations.
- Square and round sockets conform to leading tap sizes.
- Suitable for both machine- and hand-tapping.

Available as sets or individual pieces.



Tapping into good ideas for over 110 years.

[www.WaltonTools.com](http://www.WaltonTools.com)

(860) 523-5231  
sales@waltontools.com

Circle 117 on card or click "PTEN e-inquiry" on VehicleServicePros.com

**K-TOOL INTERNATIONAL**

**K-TOOL HAS WHAT MECHANICS NEED**

Ratchets, Wrenches, Screwdrivers, Pry Bars, Tool Storage, Lighting, Fans, and much more!

[KTOOLINTERNATIONAL.COM](http://KTOOLINTERNATIONAL.COM)      HEAVYWEIGHT QUALITY. KNOCKOUT PRICE.

Circle 119 on card or click "PTEN e-inquiry" on VehicleServicePros.com

## Professional Affordable Auto Borescopes

- Articulating borescopes bend back to view at any angle
- Compatible with PC's, smart phones, tablets, or LCD monitors
- Store and share videos and photos



Distributors Wanted

 **Oasis Scientific, Inc.**  
We help you see better!

[www.oasisscientific.com](http://www.oasisscientific.com)  
[info@OasisScientific.com](mailto:info@OasisScientific.com)  
Phone: 864-469-0919

Circle 120 on card or click "PTEN e-inquiry" on VehicleServicePros.com

56 PTEN © SEPTEMBER 2022 © [www.VehicleServicePros.com](http://www.VehicleServicePros.com)



## CATEGORY SPOTLIGHT

Hand Tools & Specialty Tools



## SOFT TOUCH AND HAMMER RESISTANT HANDLES

The **Mueller-Kueps Heavy Duty Duo Handle Pry Bar**, No. 276 342V2, features two ergonomic, soft touch and hammer resistant handles, allowing for two-handed use. Made with special steel that has been hardened and tempered, the pry bar is ideal for heavy duty jobs such as trucks and offshore work. The pry bar has a large striking cap and a 45-degree pry tip.

Circle 118 on card or click "PTEN e-inquiry" on VehicleServicePros.com

## INTERCHANGEABLE KEYS FOR VARIOUS APPLICATIONS

The **GEARWRENCH 33-pc Ratcheting T-Handle Hex Key Set**, No.

83518, features interchangeable keys for a wide range of uses and applications. The keys are made with alloy steel for maximum strength and to resist rotational distortion. The chamfered edges on both ends help guide the key into the fastener smoothly and quickly. The ratcheting handle increases speed when tightening and loosening fasteners and its handle provides a comfort dual material grip to allow for added torque and non-slip use. The set includes a blow molded case for storage and organization. The set meets or exceeds ASME standards.

Circle 120 on card or click "PTEN e-inquiry" on VehicleServicePros.com

## IDEAL FOR EXHAUST WORK, BODY WORK, AND DASHBOARDS

The **EZRED 8" S-Shaped Quarter Stick**, No. 4SS8, features a compact design to allow easy access inside tight corners. The tool is forged from chrome vanadium steel, and is ideal for exhaust work, body work, dashboards, motorcycles, inside fan cowls, and other hard-to-reach areas. With a 1/4" square socket and magnetic bit drive, the tool works for most general-purpose fastener-driving, and requires only 5 degrees to move fasteners.

Circle 121 on card or click "PTEN e-inquiry" on VehicleServicePros.com







**INCLUDES 11 MAGNETIC TIP BITS**

The **Vessel Low-Profile Flat Plate Ratchet Screwdriver Sets**, Nos. TX-76U and TX-79U, are ideal for use in very limited spaces. Both sets include a ratchet, a 2-pc internal bit storage, and an 8-pc external storage. The ratchet measures 4" in length and has a total height of 0.7" after attaching a 0.7" long insert bit (13/32" height without bit insertion). The TX-76U is with a straight ratchet whereas the TX-79U offers a 15-degree angle. The magnetic tip bits include: slotted 4mm and 6mm; Phillips PH1, PH2, and PH3; Torx T20, T25, T27, and T30; and Metric hex: 3mm, 4mm, and 5mm.

Circle 122 on card or click "PTEN e-inquiry" on VehicleServicePros.com



**CONVENIENT THUMB-OPERATED REVERSE SWITCH MECHANISM**

The **Dynamic Tools 108-Tooth Ratchets** are industrial-quality ratchets designed for budget-sensitive professionals. Featuring a 108-tooth gear with 3.5-degree arc swing, the ratchets have a nickel-plate mirror chrome finish for maximum corrosion resistance. A secure socket lock keeps sockets firmly installed until ejected via the quick-release button. A convenient thumb-operated reverse switch mechanism easily changes between tightening and loosening operation. The sleek, comfortable handle is user friendly, while the low-profile head provides ideal access in confined spaces. The ratchets are available in 1/4", 3/8", and 1/2" drive, or can be purchased as a set of three (No. D001309).

Circle 123 on card or click "PTEN e-inquiry" on VehicleServicePros.com



**AVAILABLE IN TWO SIZES AND WITH AN OPTIONAL CUTTER**

The **Snap-on Flat Jaw Locking Pliers** provide ideal fastening power with its patent-pending Power Ring that increases thread strength and delivers a clamping force up to 5,000 lbs. The locking pliers feature a pinned and brazed upper jaw to ensure a bond between the upper jaw and the pliers body. They also have an oversized adjustment screw with a wide head that provides a comfortable gripping surface, making adjustments easier on hands. The smooth and polished trigger allows for easy release. The locking pliers have a bright nickel finish for a classic look and come in two sizes (7" and 10") and with an optional cutter. Made in the U.S.A.

Circle 124 on card or click "PTEN e-inquiry" on VehicleServicePros.com



**FEATURES AN ALL-METAL CORE FOR DURABILITY**

The **Milwaukee Tool 4-pc Hose Pick Set**, No. 48-22-9217, features an all-metal core for increased durability. Each pick has a specific angle for different applications while the reinforced tip resists bending when loosening stubborn hoses. The flat pick provides puncture protection and reduces damage to hoses. The tool's grip handles give increased tool control and comfort. The set contains a hook, 90-degrees, 45-degrees, and flat hose pick along with a durable storage tray for easy access and organization. The picks are chrome-plated to provide protection against rust.

Circle 125 on card or click "PTEN e-inquiry" on VehicleServicePros.com

Watch this product in action here: [VehicleServicePros.com/21277044](http://VehicleServicePros.com/21277044)

**MARKETPLACE**

Contact James Hwang at [JHwang@EndeavorB2B.com](mailto:JHwang@EndeavorB2B.com) for advertising information.

**Use All the Tools of the Trade!**



**Professional Tool & Equipment News offers a wide variety of classified opportunities just waiting for you!**

Contact James Hwang for more information at 949.933.94189  
E-Mail: [Jhwang@endeavorb2b.com](mailto:Jhwang@endeavorb2b.com)

**TURN YOUR TOOL IDEA INTO MONEY**

**LISLE CORPORATION CURRENTLY PAYS ROYALTIES TO OVER 120 INDIVIDUALS.**

Lisle has been in business for over 110 years and for over 40 years have been working with individuals on an award or royalty basis. If you have an original tool idea which others may need, we have a procedure to evaluate your idea.



**Respond now to request an idea disclosure packet.**

P.O. Box 89 • Clarinda, IA 51632-0089  
712-542-5101 • Fax 712-542-6591  
[www.lislecorp.com/about/program](http://www.lislecorp.com/about/program)



# Passing on a legacy

This shop owner came across a green, 223" Cornwell toolbox he had to have.

By **Brandon Lewis**, *Contributing Writer*

**J**acob Eldridge has been a technician since before he could legally buy a drink. He's always loved cars and bonded with his father-in-law, a long time shop owner, over repairing vehicles. When his father-in-law became ill, Eldridge bought the shop from him — Don's Auto Center — and has run it ever since. The shop is located in Corsicana, Texas.

About 18 months ago, Eldridge was looking for a new toolbox, one he could consolidate all his tools into and organize. Over the last two decades, he's had multiple brands of boxes, including three Snap-on, two Mac

## »»» OWNER

### Jacob Eldridge

Shop: Don's Auto Center

Location: Corsicana, Texas

Tools, and two Cornwell boxes. After a few months of looking, he came across a green, 223" Cornwell toolbox he had to have.

"I wanted one box. I had two Cornwell boxes and two Mac boxes before this box, and they weren't the same color and size. I wanted everything to match," Eldridge said.

One of the features of his current Cornwell box that drew Eldridge immediately was the charging cabinet. He noted it's big enough to hold all of his cordless tools,

which happen to be his favorite type of tools.

"I love all my Milwaukee cordless tools," Eldridge said. "They're really strong tools. I use a lot of the 1/4" when I do a lot of my interior work. The ratchets are really fast, and the batteries last good. It allows me to do all the work I need to do all day with a lot of flexibility. I've got a ton of M12 and M18's."

One of the advantages of having a big toolbox is it is a lot easier to organize the tools the way you see fit. For Eldridge, that means putting each kind of tool into its own drawer.

"Everything has a place," he noted. "There's two sides to the box. On the one side, I have all my sockets in my top drawer. The next drawer down I have my metrics. After that comes my standard wrenches, and then I have my pliers and pullers. On the other side, I have my extensions and ratchets in one drawer, my torque's and Allen's are in another drawer, and then I have my solder iron in another drawer."

When asked if he plans on adding any other tools to his arsenal, Eldridge said he's not specifically looking to add any tools to his box at the moment.

"Mainly now, I just buy special tools. With vehicle repair, you have to stay up on your tools because certain jobs need certain tools I may not have, so I will buy those, and then I will replace any tool I lose, but I'm not looking to add any specific tools to my collection right now."

Don's Auto Shop currently has four employees. As for the type of work the shop conducts, Eldridge was quick to point to almost everything.

"We do all mechanical work, and a lot of work on foreign cars," the shop owner said. "The only thing we don't do is alignments and rebuild transmissions."

For 21 years, Eldridge has seen and done a lot of repairs on vehicles. When his father-in-law passed away a few years ago, he did not hesitate to keep the shop open.

"I want to continue building on his legacy," the 40-year-old said. "You do what you're good at. I'm good at fixing cars." ❌



Want to show off YOUR Big-Time Box? For more information, email [Editor@VehicleServicePros.com](mailto:Editor@VehicleServicePros.com).

# BendPak®

YOU'RE INVITED

## COME VISIT US!

SAVE BIG DURING THE SHOW

NOV 1<sup>ST</sup> - 4<sup>TH</sup>, 2022

# SEMA

SHOW



LAS VEGAS  
CONVENTION CENTER

## WE'LL BE AT 2 CONVENIENT LOCATIONS

SEMA and BendPak are back again, and we're coming in loaded with an amazing display of world-class equipment. Get up close and personal with some of our top brands, like **QuickJack** and **Autostacker** and of course, **legendary BendPak lifts**. When you need a break from the heat, stop by our **Cool Boss** exhibit and chill out with our new **COOLBLAST** and **COOLBREEZE** Series! We couldn't fit it all in one booth, so be sure to look for us out front by the racetrack, and upstairs in the south hall. See you there!

## SEE LIVE DEMOS!



## WIN PRIZES

Inside Booth #37117  
South Hall Upper

Outside Booth #81030  
Silver Lot



## CHECK OUT OUR NEWEST PRODUCT!

ERGO-RS

Adjustable-height rolling work seat



**COOL BOSS™** **QUICKJACK™** **AUTOSTACKER™** **ergochair™**

1-800-253-2363 • [bendpak.com/SEMA](http://bendpak.com/SEMA)

© 2022 BendPak Inc. BendPak is a registered trademark.

**BendPak®**

Circle 126 on card or click "PTEN e-inquiry" on [VehicleServicePros.com](http://VehicleServicePros.com)



**+ IDC5  
CAR**

# THE ALL-IN-ONE CAR PACKAGE FROM TEXA.

Start scanning.

For this year's great prize giveaway, TEXA is offering the NANO S scan tool, a tablet, and IDC5 CAR Software. Big things come in small packages.



## NANO S Scan Tool      Lightweight Tablet      TEXA IDC5 CAR



TEXA offers a range of scan tools that offer unbeatable coverage.

- Light weight, easy to use
- Excellent ROI
- Powerful inspection light to illuminate the diagnostic socket
- Bluetooth Class1 wireless connectivity
- Full Bi-Directional Capabilities



This new tablet comes with IDC5 car ready to go immediately.

- 10.1" Rugged Tablet
- Pre Loaded IDC5 CAR
- USB 3.0
- Lightweight
- Metal Housing
- Rubber Grips
- USB Type C
- Mini HDMI



Our car software is intuitive and packed with unbeatable coverage.

- Coverage includes all passenger cars: Domestic, Asian, European, & LCVs.
- Maintenance resets, component testing, and adjustments
- VIN code search
- Solved problems and repair procedures
- Dashboard features and wiring diagrams
- Recording drive test and playback

**TEXA**  
 TEXA USA inc.  
 409 Joyce Kilmer Ave,  
 New Brunswick, NJ, 08901  
 www.texausa.com  
 northamerica@texa.com  
 +1 855.200.8392

Circle 127 on card or click "PTEN e-inquiry" on VehicleServicePros.com