

# PROFESSIONAL DISTRIBUTOR

JUNE 2013 VOL. 21, NO. 5

*The Distribution Network Connection*



## A PROMISING FUTURE IN TEXAS

Newcomer Clint Maxwell has only been at it for two and half years. **Page 8**

**VEHICLESERVICEPROS**<sup>com</sup>  
OFFICIAL WEBSITE OF PROFESSIONAL DISTRIBUTOR

**EXCLUSIVE!**

**2013 Ace Tool Co. national dealer expo coverage**

See pictures from the trade show floor, read about training sessions and hear recorded interviews with show attendees.

Visit [www.VehicleServicePros.com/distributors](http://www.VehicleServicePros.com/distributors).

Presorted  
First-Class  
Permit No. 246  
Lebanon Junction, KY

**CYGNUS**  
BUSINESS MEDIA

PLEASE SEND TO:  
P.O. BOX 3257  
NORTHBROOK, IL 60065-3257  
CHANGE SERVICE REQUESTED



# COOLING PRODUCTS ARE IN STOCK

## ENFRIAMIENTO PRODUCTOS POR MONTAÑA

### MTN5036DD

#### 36" Direct Drive Drum Fan

- Two speed direct drive for maximum energy efficiency
  - UL approved • 1 year warranty on material & workmanship
- Power: 469Hi; 416 Low; CFM: 11,600 Hi; 10,550 Low  
RPM: 1086 Hi; 998 Low

36 "Ventilador de tambor de accionamiento directo  
• Dos de accionamiento directo de velocidad para la máxima eficiencia energética  
• Aprobado por UL  
• Garantía de 1 año en el material y mano de obra  
Potencia: 469Hi; 416 Low;  
CFM: 11600 Alta ,  
10550 Baja  
RPM: 1086 Alta ,  
998 Baja

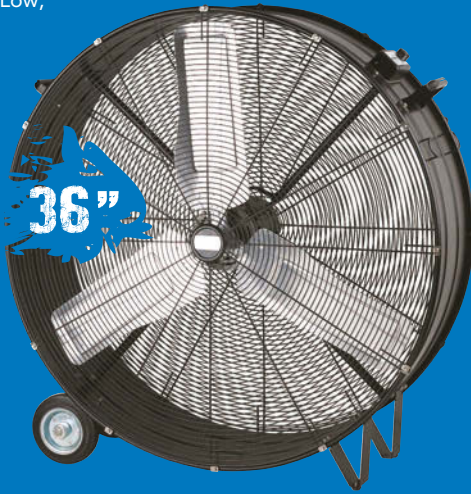

**QUALITY  
SELECTION  
AND VALUE**

### MTN5042BD

#### 42" Belt Drive Drum Fan

- Two speed belt drive fan
  - UL approved • 1 year warranty on material & workmanship
- Power: 631Hi; 509 Low; CFM: 14,800 Hi; 11,250 Low;  
RPM: 1082 Hi; 978 Low

42 "correa de transmisión del ventilador del tambor  
• El ventilador de transmisión por correa de dos velocidades  
• Aprobado por UL  
• garantía de 1 año en el material y mano de obra  
Potencia: 631Hi; 509 Low; CFM: 14800 Alta, 11250 Low;  
RPM: 1082 Alta, 978 Baja

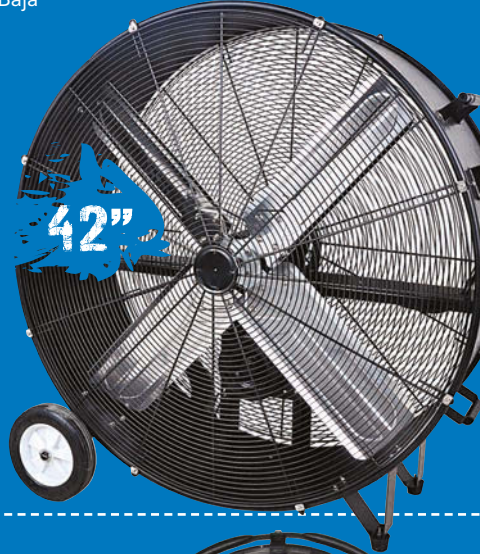

### MTN5000

#### Big Chill XXL Blower (1,200CFM)

- Moves 1,200CFM of air up to 30 feet away

Big Chill XXL Blower (1200 CFM)  
• Mueve 1200 CFM de aire de hasta 30 metros de distancia



### MTN5200

#### "The Big Chill" Blower

- 310 cubic feet of air flow/minute

"The Big Chill" Blower  
• 310 pies cúbicos de flujo de aire / minuto

### MTN5020

#### 20" High Velocity Floor Fan

- Tilts vertically and horizontally for optimal air direction
  - OSHA and UL approved
  - 1 year warranty on material & workmanship
- Power: 159 Hi; 147 Med; 135 Low;  
CFM: 4230 Hi; 3550 Med; 2995 Low  
RPM: 1500 Hi; 1385 Med; 1280 Low

20 "High Floor Fan Velocity  
• Se inclina verticalmente y horizontalmente para dirección del aire óptima  
• OSHA y UL aprobados  
• Garantía de 1 año en el material y mano de obra  
Potencia: 159 Hi; 147 Med, 135 Bajo;  
CFM: 4230 Alta, Med 3550; 2995 baja  
RPM: 1500 Alta, Med 1385; 1280 baja



Call ISN Today to order your Mountain™ Fans and any other Automotive Tools and Equipment. Our friendly, experienced sales team is ready to speak with you now.

Llame ISN Hoy pedir sus ventiladores™ de montaña y otras herramientas y equipos de automoviles. Nuestro amable y experimentado equipo de ventas está listo para hablar con usted ahora.



Lakeland, Florida.....	800.966.8478
Atlanta, Georgia.....	800.255.6107
Baltimore, Maryland.....	800.638.3730
Dallas, Texas.....	800.966.8478
Fort Wayne, Indiana.....	800.638.3730
W. Sacramento & Fresno, California.....	800.392.4097

# BY MOUNTAIN CK NOW

ÑA ESTÁN EN LA ACCIÓN



## MTN5030

### 30" Pedestal Fan

- OSHA and UL approved
  - 1 year warranty on material & workmanship
- Power: 161Hi; 136 Med; 122 Low  
CFM: 4835 Hi; 3780 Med; 2925 Low  
RPM: 1116 Hi; 968 Med; 856 Low

30 "Ventilador de Pedestal  
• OSHA y UL aprobados  
• Garantía de 1 año en el material y mano de obra  
Potencia: 161Hi; 136 Med; 122 Baja  
CFM: Alta 4835,  
Med 3780; 2925 baja  
RPM: 1116 Hi; Med 968; 856 Baja

## DUAL ANGLE ADJUSTMENT

24"

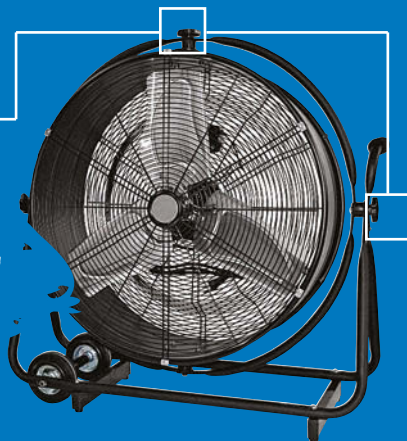

## MTN5024

### 24" Orbital Drum Fan, Vertical and Horizontal Air Flow

- Orbital adjustment allows fan to tilt up and down as well as side to side for maximum air flow
  - OSHA and UL approved
  - 1 year warranty on material & workmanship
- Power: 273Hi; 251 Low; CFM: 6300 Hi; 4900 Low  
RPM: 1511 Hi; 1438 Low

24 "Fan Drum Orbital,  
Flujo de aire vertical y horizontal  
• Ajuste de Orbital permite fan se incline hacia arriba y abajo, así como un lado a otro para el flujo de aire máximo  
• OSHA y UL aprobados  
• garantía de 1 año en el material y mano de obra  
Potencia: 273Hi; 251 Low; CFM: 6300 Hi; 4900 baja  
RPM: 1511 Hi; 1438 baja

Spanish Speaking Team Members

## Valoramos a nuestros clientes de habla hispana.

Llame al **1.800.966.8478** hoy para hablar con uno de nuestros profesionales bilingües. Podemos ayudar con todas sus herramientas de automoviles y el equipo necesario.

**Miguel Santiago en la extensión 1724**  
o **Billy Moore en la extensión 1579.**

o por correo electrónico:  
**billym@isnweb.com**  
o **miguels@isnweb.com**

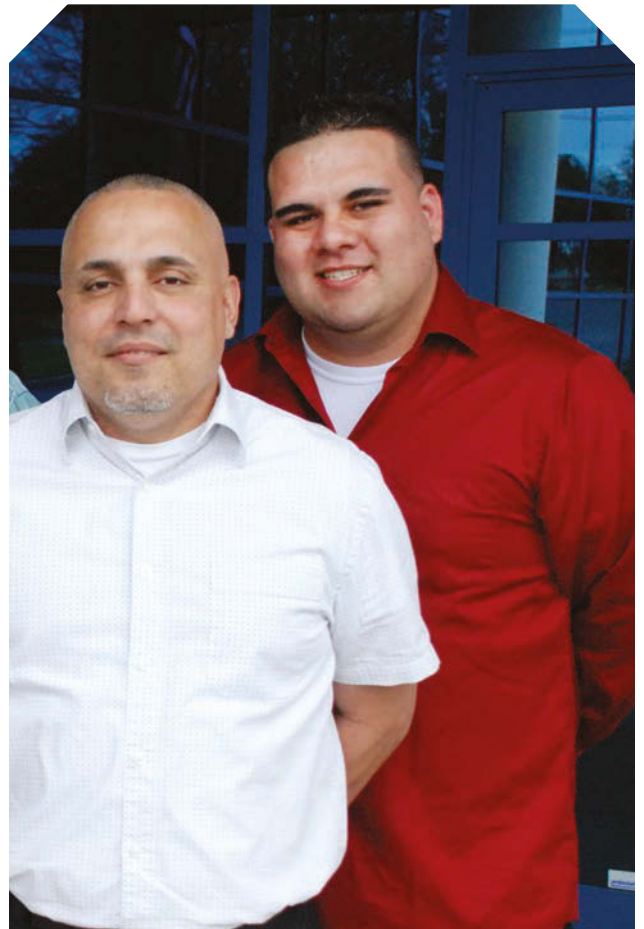

 *Tools Across America* <sup>SM</sup>  
**ISN** **Integrated Supply**  
**Network, LLC.**

Enter 15 at "e-inquiry" on [vehicleservicepros.com](http://vehicleservicepros.com)

Published by  
**Cygnus Business Media**  
P.O. Box 803, 1233 Janesville Ave.  
Fort Atkinson, WI 53538-0803  
920-563-6388 • 800-547-7377  
Fax: 920-563-1699

**PUBLISHER** Sarah Shelstrom  
Sarah.Shelstrom@Cygnus.com

**EDITOR** Elliot Maras  
800-547-7377 x1693 Fax: 920-563-1699  
Elliot.Maras@Cygnus.com

**MANAGING EDITOR** Erica Schulz  
800-547-7377 x1630 Fax: 920-563-1699  
Erica.Schulz@Cygnus.com

**ASSISTANT EDITOR** Craig Truglia  
800-547-7377 x6154 Fax: 920-563-1699  
Craig.Truglia@Cygnus.com

**PRODUCTION SERVICES REP** Wes Gray  
800-547-7377 x1337 Wes.Gray@Cygnus.com

**ART DIRECTOR** Meredith Burger

**LIST RENTAL REP** Elizabeth Jackson  
847-492-1350 x18 ejackson@meritdirect.com

**AUDIENCE DEVELOPMENT MANAGER** Terri Pettit

**CYGNUS BUSINESS MEDIA**

John French – Chief Executive Officer  
Paul Bonaiuto – Chief Financial Officer  
Gloria Cosby – Executive Vice President  
Julie Nachtigal – Vice President, Audience Development  
Eric Kammerzelt – Vice President, Technology  
Curt Pordes – Vice President, Production Operations  
Ed Wood – Vice President, Human Resources  
Larry M. Greenberger – Group Publisher

**FOUNDER** Rudy Wolf

**Cygnus Reprint Services**

For reprints and licensing please contact  
Nick Iademarco at Wright's Media 877-652-5295 ext. 102  
or niademarco@wrightsmedia.com

Professional Distributor (ISSN 1553-6211) (online 2150-2080)  
is published nine times a year in Feb., March, April, May, June,  
Aug., Sept., Oct. and Dec. by Cygnus Business Media, 1233  
Janesville Avenue, Fort Atkinson, WI 53538. Postage paid at Fort  
Atkinson, WI and additional mailing offices. Subscription rates, in  
U.S. currency only, are: one year \$35; two years \$65; Can/Mex  
\$50 one year; \$95 two years; international, \$75 one year; \$145  
two years. Back issues are \$10 per copy. Send check to: Cygnus  
Business Media, P.O. Box 3257, Northbrook, IL 60065-3257.  
POSTMASTER: Please send change of address to Professional  
Distributor, P.O. Box 3257, Northbrook, IL 60065-3257. Canada  
Post PM40063731. Return Undeliverable Canadian Addresses  
to: Professional Distributor, Station A, P.O. Box 54,  
Windsor, ON, N9A 6J5. For change of address or subscription  
information: Toll-free (877) 382-9187 or (847) 559-7598  
Email: circ.profdistmag@omeda.com

Printed in the U.S. Volume 21, Number 5; June 2013



Professional Distributor® magazine is a Registered  
Trademark of Cygnus Business Media Inc.



**COVER STORY/DISTRIBUTOR PROFILE**



**Independent finds his niche in rural Texas**

Largely self-taught young man develops a loyal following in a short time.

**Page 8**



**EXCLUSIVE!**

**24 PTEN 2013 Innovation Award winners**

Product details for the top product in each submitted category.

**FEATURES**

**20 Special Feature**

Maintenance tips for 'summerizing' trucks.

**36 Driving Sales**

Product information on diagnostic scan tools.

**44 In Focus Products**

Product details for tools you can stock:

- Ingersoll Rand 3/8" and 1/2" Cordless Ratchet and Wrenches
- Hein Werner Engine Stand
- SP Tools Ford 6.7L Diesel Injector Socket Set



**DEPARTMENTS**

**6 Editor's Note**

Innovation Awards: A great conversation starter with customers.

**22 Sales Q&A**

How to stock for success.

**26 Most Wanted**

The top requested products from technicians according to our sister publication, *Professional Tool & Equipment News*.

**48 Sneak Peek**

See new tools and equipment before technicians do in *PTEN* magazine.

**50 Tales from the Road**

Dealer won't forget the Boston Marathon bombing.

**VEHICLESERVICEPROS**  
OFFICIAL WEBSITE OF PROFESSIONAL DISTRIBUTOR

**EXCLUSIVE!** "Gated" content for Professional Distributor readers!  
The VehicleServicePros.com website has exclusive business management content.  
Visit [VehicleServicePros.com/10893105](http://VehicleServicePros.com/10893105)

# What do you get when you take the most commonly used service modules from our powerful MaxiDAS® DS708?

*all new unique*  
 The Autel MaxiCheck Line Of Service Tools  
 with complete functionality



## POWERFUL, YET AFFORDABLE FOR DOMESTIC, ASIAN, AND EUROPEAN VEHICLES

The Autel MaxiCheck service tool series is the next generation of diagnostic tools which feature complete unparalleled coverage for TPMS, SRS/ABS, EPB, Brake Pad Thickness Resets, Oil Light Service, Diesel Particulate Filter (DPF), enhanced OBD-II, and much more!



**TOMORROW'S TECHNOLOGY, FOR TODAY'S TECHNICIAN**



www.AUTEL.US  
 1-855-288-3587

# Innovation Awards: A great conversation starter with customers



**BY ELLIOT MARAS**  
Editor  
216-360-0050  
Elliot@VehicleServicePros.com  
1233 Janesville Ave.  
Fort Atkinson, WI 53538

**S**elling tools on a truck has many demands. One that most tool sales people agree on is being able to engage customers – in the customer's shop and on the truck. There are many different ways to engage customers.

The first goal many of you work on is getting a conversation going, be it about business or other matters. The second goal is to get the conversation focused on tools.

The current issue of *Professional Distributor* offers one of the greatest conversation starters ever presented in the magazine – the annual *PTEN* Innovation Awards, beginning on page 28. The Innovation Awards recognize the most innovative products introduced in the last year to the automotive aftermarket. For 10 years, *PTEN*, *Professional Distributor's* sister magazine that goes to shops and technicians, has recognized the most innovative tools.

## Customers await the awards

Every year, shops and technicians look forward to the *PTEN* Innovation Awards. Technicians want tools that help them get jobs done right the first time in an efficient manner.

The process of gathering nominations, judging the nominees and selecting the winners for the Innovation Awards is a very exciting time for the automotive tool industry. It begins in the spring when nominations are announced and concludes at the fall AAPEX Show where the winners are honored on the trade show floor.

Tool and equipment manufacturers

submit products every year, hoping to win the recognition from *PTEN's* panel of judges. The nominations include detailed explanations from manufacturers about product features, along with pictures, and in more than half the cases, videos. The judges are veteran technicians and shop owners who bring a “real world” view to evaluating tools.

The judges get busy in the spring evaluating the nominations. Product categories this year include air conditioning, air tools, battery charging/starting, software, diagnostic test equipment, electrical systems, fluid exchange, hand tools, heavy duty tools, inspection tools, jacks and stands, leak detectors, lifts, lighting, power tools, repair information, safety equipment, scan tools, shop equipment, specialty tools, tire and wheel service tools, tool accessories and tool storage.

Judges are asked to rank the nominees for time savings, task simplification, uniqueness, level of improvement over current tool and ease of use.

This year there were 80 nominations, an outstanding number.

## Judges relish the task

The judges work tirelessly on these evaluations. *PTEN* compensates them for their time, but the main reason the judges get involved in this project is their love of tools and the excitement they share finding out how manufacturers are helping them do their jobs better and faster. This much is obvious from the comments the judges make about the tools in the evaluation forms.

Here's a judge's comment about LT991 hollow end line taps from Lock Technology, winner in the air conditioning category: “I see two positive things this tool can do. One is that it would save a tremendous amount of time by

repairing this tube end as replacing some of these lines are very costly and hard-to-replace at times. The other is its simplicity of use.”

A comment on Inspection Connection's ProSpec, winner in the computers and software category: “This is a good sales and service aid similar to dealer-level check-in tablets now in use. The conductivity is what will make for the real value and use.”

A comment on ACDelco's AR12044B Li-ion 18V 3/8” angle impact wrench with digital clutch: “The digital clutch on this ratchet is quite interesting; it allows for safer operation on delicate work.”

This year, the judges displayed keen interest in ways to address new SAE International standards. There was also a lot of interest in tools to address the emerging field of hybrid vehicles. And as always, a lot of interest was shown in diagnostic tools and repair information sources that can help shops work on more vehicles.

Customers are looking to you for ideas about what's new and exciting. What better way to engage the customers than to let them know which of the products you offer won an Innovation Award?

This issue marks *Professional Distributor's* most extensive section on the Innovation Award winners as they appear in the June *PTEN* magazine. You now have an opportunity to talk about the winning tools just as your customers are learning about them in *PTEN* magazine.

Now is your chance to share the excitement of the Innovation Awards with your customers. ■



Stinger® Lite Pipe RECHARGEABLE LED WORK LIGHT SYSTEM

# FLOOD THE ENGINE

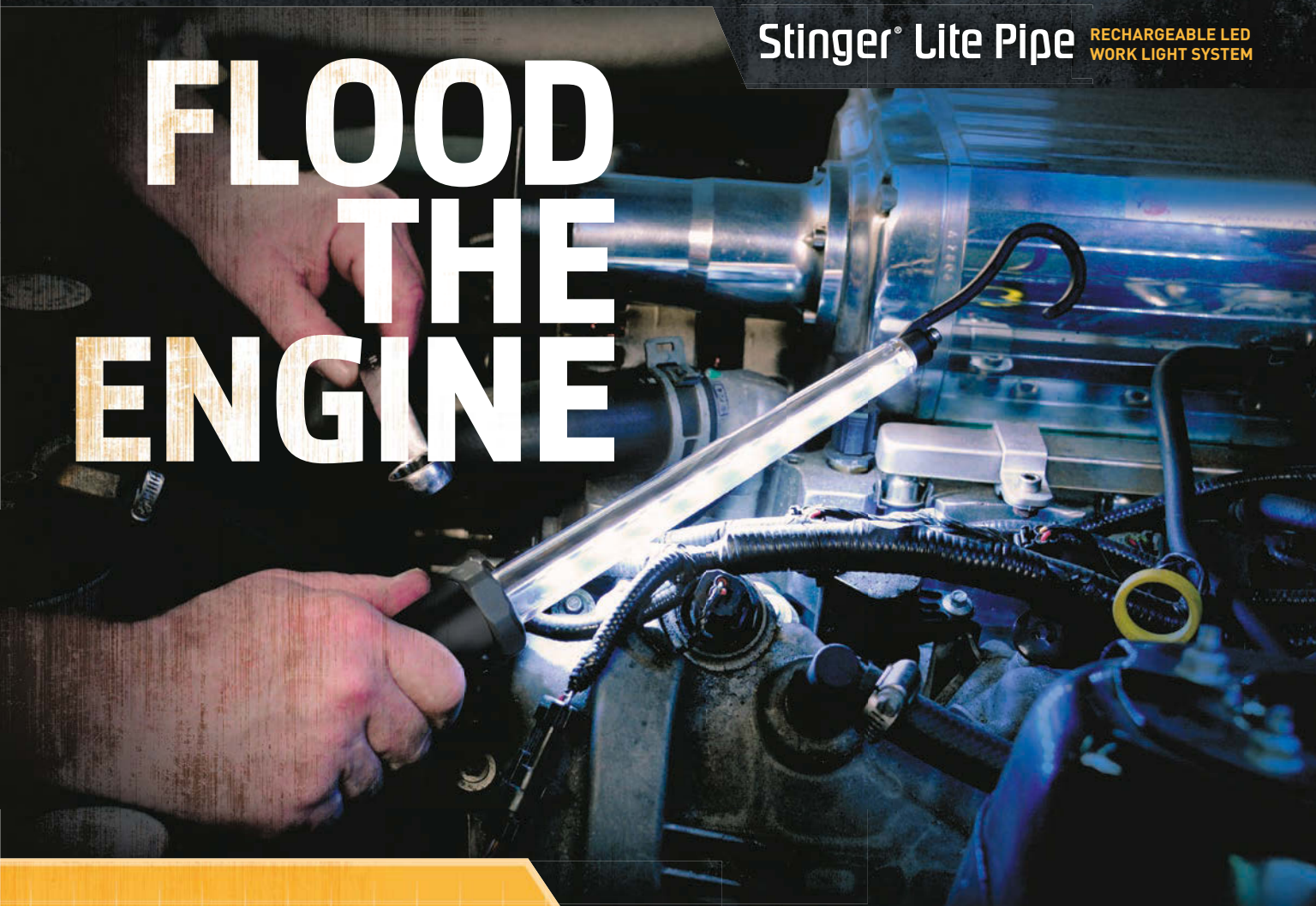

## WITH 220 LUMENS

Introducing the NEW **STINGER® LITE PIPE**. Its high impact 9-inch light bar is constructed of unbreakable polycarbonate with a scratch resistant coating to ensure that it can hang with the professionals. Speaking of hanging, the Lite Pipe includes a removable rotating hook so it can do just that, giving you the freedom to work with both hands. It features 220 lumens and 3.25 hours of run time so it works just as hard as you. The Lite Pipe is available as a complete unit or as a conversion kit for your Xenon Stinger; either way, it illuminates more tight spaces so you can find the solution faster.



3.25 hours of run time



Available as a complete unit or as a conversion kit

Anti-roll rubber ring

High-Impact, 9" light bar

Removable, rotatable hang-hook



**STREAMLIGHT**

Visit us at ISN booth # 1541

Enter 17 at "e-inquiry" on [VehicleServicePros.com](http://VehicleServicePros.com)

©2013 STREAMLIGHT, INC.

30 EAGLEVILLE ROAD, EAGLEVILLE, PA 19403 | 800.523.7488 **CONNECT WITH US** [WWW.STREAMLIGHT.COM](http://WWW.STREAMLIGHT.COM)



## *Texas Independence:* Newcomer carries the torch in a changing economy

BY ELLIOT MARAS, EDITOR

**C**lint Maxwell never planned to be in business for himself. As a young man, he had aspirations to be an engineer or an architect. But while attending the University of Texas in Arlington, he realized he wasn't sure what he wanted to do.

Fast forward to today, and the 35-year-old Maxwell has established himself as a reputable, independent mobile distributor in Stephenville, Texas, a rural area just west of Dallas. In the past two and a half years, this largely self-taught Texan has paid off half of the money he borrowed to get himself started in tool sales and is now looking to invest in a larger truck and a computerized management system. He proves that an ambitious, dedicated individual with good people skills can be successful in mobile tool sales.

Like many successful business owners, Maxwell has been able to use his natural gifts – in his case, an outgoing personality – and leverage his familiarity with his region to take advantage of an opportunity that, until a few years ago, he didn't even know existed. But his ride – no pun intended – hasn't been smooth.

After a stint in college, Maxwell went to work at DHL, the courier service, as a driver. Over the next 13 years, he worked his way into management as a supervisor, and was moving up the corporate ladder. He was upbeat about his future.

### **A setback and a new beginning**

Then the recession hit. In 2009, Maxwell fell victim to a massive downsizing at DHL. He immediately teamed with a “downsized” fellow employee on a start-up business, an airline luggage delivery service. But the venture fizzled in less than a year.

Things weren't looking good for Maxwell in late 2010. He had two young children and a wife to take care of.

Little did he know that his next opportunity was awaiting him in his own backyard.

Maxwell's Uncle Bob owned an independent mobile tool company, WB Tool Truck. When Uncle Bob suddenly took ill, one of Maxwell's cousins took over the route on a temporary basis. WB Tool Truck had a client base of 150 accounts established over 22 years in a 360-square-mile area.

When his cousin asked him to help out on the truck, Maxwell obliged. Little did he know he would soon be asked to buy the business.

No decision was made until Uncle Bob passed

away. At that point, Maxwell decided to buy the small company from his aunt, who was also the business's bookkeeper. They agreed on a purchase price for the inventory, the truck (a 1979 16' Ford Kubmaster that was originally a ServiceMaster carpet truck), the customers and the goodwill.

Maxwell borrowed \$10,000 from a

*(Continued Page 10)*



**A customer reads the package of a Precision Instruments torque wrench.**

*Clint Maxwell converses with customers to get them to stay on the truck as long as possible, knowing he increases his chance to make a sale.*

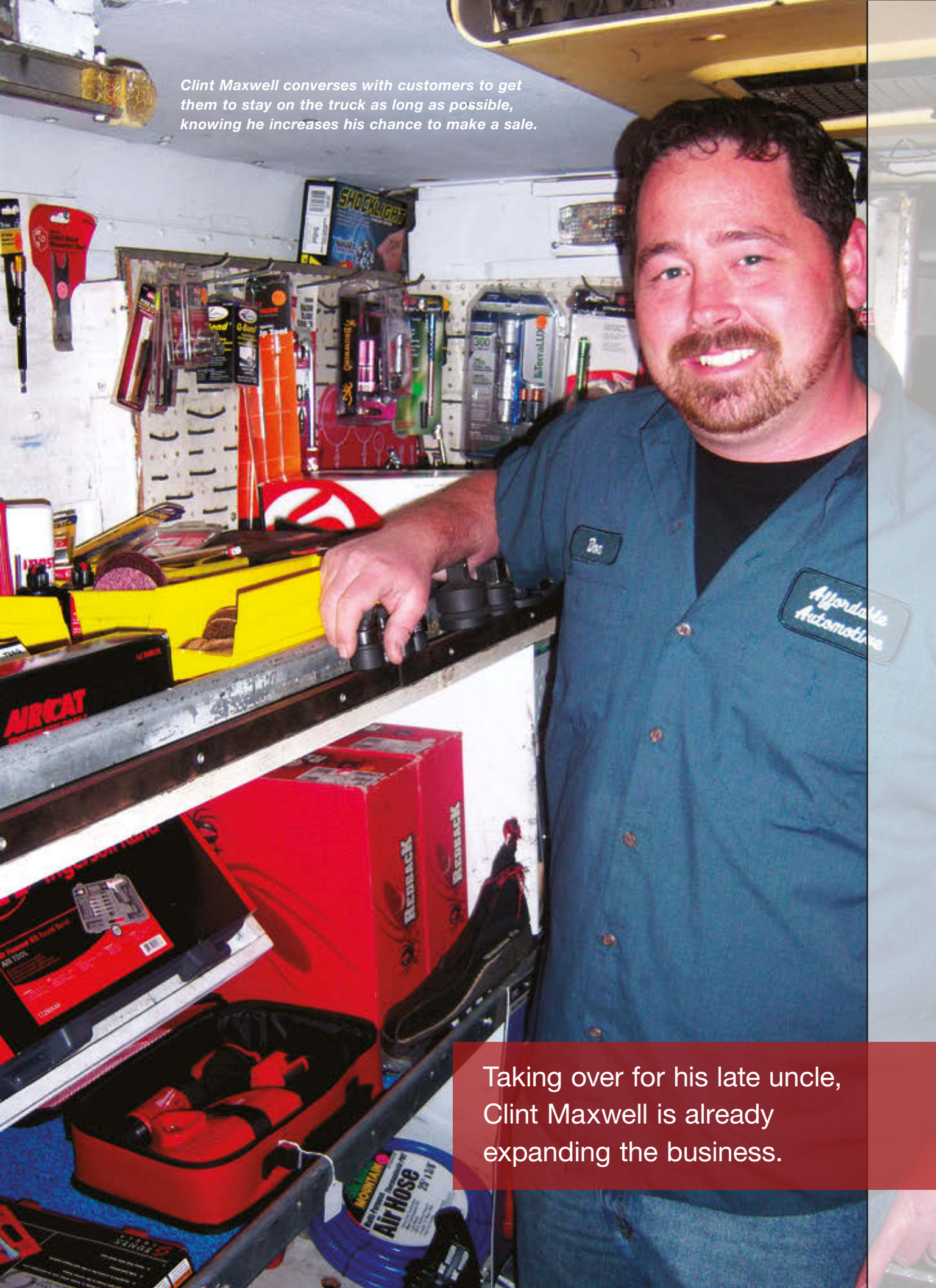

Taking over for his late uncle, Clint Maxwell is already expanding the business.

**Clint Maxwell, right, gives an Ingersoll Rand air hammer to a customer at a shop that services oil tankers.**

local bank, but carried a much larger balance with his aunt who sold him the business under a seller financing arrangement.

### Tool education begins

Maxwell knew almost nothing about the tool business except for what he learned driving for a few weeks with his cousin, who was also a novice. His aunt was able to give him a good overview of the inventory and how much he needed to sell to cover his costs and make a profit. His uncle had grossed around \$200,000 a year, yielding a reasonable income for the couple.

Integrated Supply Network (ISN), his main tool supplier, advised him on what inventory to stock. Maxwell fitted the truck with 280 stock keeping units worth about \$10,000 in retail inventory.

His aunt taught him how to manage Excel spreadsheets for keeping track of sales and collections.

Maxwell knew very little about tools, but fortunately, he wasn't shy about asking his customers what the tools do. He found most customers were willing to help him, thanks largely to their loyalty to his Uncle Bob. One customer, for instance, told him to tape his business card on all toolboxes he sold as a way to promote the business. Some customers taught him how to fix tools.

The customers told him they liked his uncle and would keep buying from WB Tool Truck if he served them well. Uncle Bob had a reputation for being fair and helpful; he would make an emergency delivery when asked. Maxwell realized he needed to do the same thing to keep his customers satisfied.

Fulfilling his uncle's reputation for attentive service wasn't easy. From day one, Maxwell made it a point to respond immediately to all customer requests for tools. Meeting these requests, he learned, takes perseverance. Finding a specific product in a catalog, on a website or over the phone can take 45 minutes, with no



## Maxwell's Top 5 Tools

- 1) Streamlight Stylus Pro
- 2) Ingersoll Rand 1/2" Cordless Impact K1 and K2
- 3) Grey Pneumatic 1719 1/2" 12-point standard fractional master set
- 4) Grey Pneumatic 1212U 3/8" drive standard length fractional universal set
- 5) GearWrench 9416 gear wrench set

guarantee of a sale. But Maxwell realized that responding to requests is a key to establishing credibility. "Guys (customers) have learned I can find things," he says. This is something that not all of his competitors are willing to do.

*Professional Distributor* was able to confirm this independently by speaking with some of Maxwell's customers. A tech at one stop said Maxwell is one of two mobile distributors who visits their shop every week. Because of this, and the fact that Maxwell is friendlier than the other distributor who comes weekly, the tech said he and the other techs prefer to patronize Maxwell.

Maxwell also learned that his uncle was known for providing the same quality

tools as the flag trucks but at a lower price. Hence, Maxwell began studying the flag catalogs and learning which manufacturers make products that can compete with the flags on quality and price.

He realized that his uncle's niche was good quality, warranted tools at a lower price than certain brand tools. But Maxwell also recognized there are some exclusive tools that flags carry that he can't offer. He realizes that some customers are loyal to certain brands and will not change. "I'm not here to compete (100 percent of the time) with franchise trucks," he says. And these flags exist throughout his market.

*(Continued Page 12)*

# PRODUCTIVITY UNLEASHED

...WITH THE  
**POWER**  
TO GET THE  
JOB DONE.

## IQ<sup>v</sup>20 Series



CORDLESS 1/2"  
IMPACT TOOL



CORDLESS 3/8"  
IMPACT TOOL



CORDLESS  
DRILL



CORDLESS  
TASK LIGHT

## R3130 3/8" 20V RATCHET WRENCH

Whether you're looking for exceptional power, portability, access, or time-saving operation, the R3130 ratchet is the right tool for the job. Get the performance you need, with 54 ft-lbs of torque — the same kind of power you'd expect from an air tool. Get the same durability, too — the proven-engineered ratchet head is the one you'll find on our air-powered ratchet. But with the IQ<sup>v</sup>20 battery, you'll get more portability, thanks to a patent-pending inline design for easier access to tight spots and 20 volts of hardworking power to keep going job after job. Learn more at [ingersollrandproducts.com/R3130](http://ingersollrandproducts.com/R3130).

**DO THE JOB. DO IT FAST. DO IT EVERY TIME.**



## COVER STORY/DISTRIBUTOR PROFILE

*A customer examines a pipe cutter on Maxwell's truck.*



There is, however, a sizeable number of customers who want the tools he carries.

### **In search of growth**

His uncle's reputation, combined with his own people skills, enabled Maxwell to meet the monthly sales goals he set for himself. He was able to generate an income similar to his uncle's. But he believed he could do even better if he served larger customers.

In the first year, he culled half of the accounts – the least profitable ones – and sought others to replace them. He visited two prospective accounts every day, and in the course of two and a half years, he rebuilt the individual customer count to 150 in 115 stops. He visits all but 20 stops weekly; the rest are bi-weekly.

His uncle's reputation has helped him win new accounts. Maxwell tells prospective customers his truck has served the market since 1989.

Another advantage Maxwell brought

to the role was his personal history in the area he serves. It is not unusual for him to see former classmates at his stops. "It helps being able to know something about their personal lives," he says. "It helps me relate to them personally."

Maxwell has a gift for gab, and he found it helpful in sustaining customer loyalty. His other sales techniques have been self-taught.

When approaching new customers, Maxwell makes a point not to badmouth the competition. He tells customers the established players carry good quality products. This carries no downside for Maxwell; by comparing himself to the competition, he places himself in good company, thereby enhancing his own credibility.

He even tells customers that they should shop different trucks to see who carries what tools.

He sometimes fixes tools that he did not sell. "When you do that for a customer, game over," he says. "If there's

something I can fix for them, it makes me look better."

When he gets a new stop, Maxwell encourages the techs to learn about his tools and ask questions. If he doesn't know something, he goes to the supplier's website. He believes an educated customer is a better customer.

He doesn't hesitate to let a trustworthy customer borrow a tool before buying it. Because the tools he carries are good quality, Maxwell has learned that most of them sell themselves. He recently sold a diagnostic tool to a repair shop after letting the shop use it for a week.

One thing that surprised him early on is how much techs will spend on tools.

### **Conversations and other sales techniques**

One of the most important insights Maxwell gained on his own was how much the techs buy on impulse. Hence, he tries to keep them on his truck as long as possible; he does this by actively engaging them in conversation. He will spend as long as an hour talking with a customer about their personal interests. He insists this helps build strong customer relations. "If I get people (talking) on their things (hobbies) five more minutes, they'll tell me something they want. I'll spend the extra time," he says.

Maxwell has found that sometimes a product sells better if it has been off the truck for awhile. "Absence makes the heart grow fonder," he says. An example is pry bars. Pry bars sold well when he first put them on the truck, then fizzled. After a two-week absence, some customers began asking for them.

Package deals also drive sales. Maxwell says it takes time to learn what tools to pair together as a package deal. The goal is to allow a customer to buy an item at a lower price by buying it as part of a package.

Sometimes he finds it helps not to put prices on packages. This causes a customer to ask about the price, which can lead to a sale, whether or not the tool in question gets purchased.

*(Continued Page 14)*

# Homak



## Industrial SERVICE CARTS for the **PROFESSIONAL**

### Durable. Dependable. Professional.

Homak's Service Carts are there when you need mobile storage that's as demanding as you are. We offer a variety of options to suit all your Industrial needs. Whether you choose the highly mobile (and vast storage capacity of the) 10 Drawer Maintenance Cart or opt for the convenience of our 2 Drawer Unit with Top Locking Slide Panels, you'll be investing in a professional grade product from a company that knows nothing else.

**Homak**

SINCE 1947.

[www.Homak.com](http://www.Homak.com)

1.800.874.6625

Enter 19 at "e-inquiry" on VehicleServicePros.com

27" PROFESSIONAL TOOL CART  
32" PROFESSIONAL - 1 DRAWER  
34" PROFESSIONAL - 3 DRAWERS  
35" PROFESSIONAL - 4 DRAWERS  
44" MAINTENANCE CART - 10 DRAWERS

Visit us at ISN booth # 542

Maxwell uses Facebook to get the word out to customers about his promotions. He runs drawings for customers to win free tools periodically. He has found this a great way to market new tools. "The next thing you know, you're selling three or four (new tools) in a shop," he says.

During holidays, he carries a lot of toys for customers' kids. This past Christmas, remote control helicopters, tanks and stun guns were popular. Pink-colored gifts were popular on Valentine's Day.

He offers more liberal payment terms than most of his competitors: 10 weeks for most tools.

He also offers credit.

How does he decide whom to extend credit to? The main consideration is the condition of their teeth. "Good teeth indicates they are responsible," Maxwell says. "Bad teeth, on the other hand, means they are irresponsible at best and a crack addict at worst."

Maxwell is wary of customers who want to buy high-ticket items without asking questions first.

He is especially wary of young techs who want to buy new toolboxes. "He

(the young tech) wants to show (off)," Maxwell says of such people. "You have to see beyond the dollar signs of the sale; you have to see the actual dollars. It's little things like that you have to watch out for."

### Administrative challenges

One of the most challenging things about doing business in Texas is the varied tax rates that counties and municipalities levy. Maxwell uses colored stickers to designate the local and county taxes which he attaches to all of his inventory. When he quotes a customer a price, it always includes the taxes.

Tagging the inventory with stickers and managing the books with Excel spreadsheets takes a lot of time. But Maxwell has found that paying his taxes monthly allows him to feel in control of his business. It helps him stay current on his receivables. He also gets a 1 percent bonus from the state for paying taxes monthly.

He normally stays within a \$14,000 purchase credit limit. "If I stay there, I'm fine," he says.

Maxwell expects his inventory to turn every two or three weeks. If an item fails

to meet that goal, he removes it from his truck and replaces it. "With a smaller truck and a smaller wallet (compared to the flags), I have to pick and choose my battles," Maxwell explains.

The hardest aspect of the job, however, is the dedication required to succeed. Maxwell has his cell phone with him at all times, and he's always on call. "You're never 'off,'" he says. And when you're having a bad day, you can't take it out on the customers.

### Dealing with collections

Maxwell is like most other distributors when asked what he most dislikes about the job: collections. While only 10 percent of the customers give him problems in this area, that 10 percent is enough to threaten his profitability. About 5 percent of the customers have to be reminded to pay and another 5 percent have to be chased.

One technique that has helped with collections is a "used and repo" bin placed prominently on one of his shelves. These are mainly tools that have been repossessed and sell at discount. "Guys pay attention," he says. He cites this as one of the most effective techniques he's used for getting paid.

For the 5 percent of customers who have to be reminded to pay, Maxwell tries to find out why they are slow to pay. Having been laid off himself, he empathizes with people in tough financial straits.

If a customer has made some payments but can't stay current, he credits the customer based on prior payments if he has to repossess the tool.

For those who skip, Maxwell follows a plan. If someone owes him money and doesn't return phone calls or emails, he visits them at home. He gets home addresses from drivers' licenses, which he requires of all customers.

He also uses social media to find information about delinquent payers. "Facebook has been valuable because people put so much information on it," he says. "People put all their information out there on the street."

## Maxwell relies on his ISN sales rep for guidance

Clint Maxwell is grateful for the guidance from his Integrated Supply Network (ISN) Lakeland, FL-based sales rep, Tim Pate, whose advice he has followed from the day he bought WB Tool Truck in Stephenville, Texas.

"Tim in himself has been a godsend for me," Maxwell says. "Tim helps me out tremendously. Especially in the beginning, he took a lot of extra time to go through sales items to make it possible for me to succeed. Not just to get me to buy products, but to know what would and wouldn't work; things my uncle had success with and carried on a regular basis; and pass on useful information and sales techniques, especially knowing I'm not a strong

salesman. Without Tim Pate, I have no idea where I'd be. He goes above and beyond for me, just as he did for my aunt and uncle."

Pate, a 17-year ISN veteran, has equal admiration for Maxwell. "He has done a phenomenal job," Pate said of Maxwell, who he said calls him four to six times a week to ask questions about tools and find out about new ISN products.

"He (Maxwell) goes the extra mile for his customers," Pate says.

"If you call an order in by 3 p.m. today, it ships same day," notes Scott Pilkenton, national sales manager at ISN. "We service over 80 percent of the entire U.S. next day."

*(Continued Page 16)*

# GRAB PRODUCTIVITY BY THE PAWLS

WITH THE **120XP** RATCHET, NOW AVAILABLE IN FLEX-HEAD

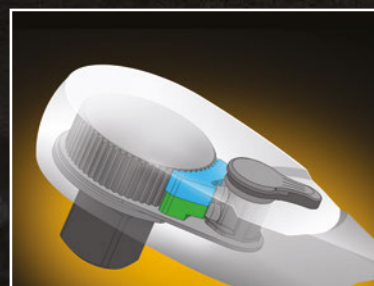

PATENT PENDING DOUBLE-STACKED PAWL™ TECHNOLOGY

120XP ratchets deliver speed, access, and 180% of ASME torque performance.\*

The Double-Stacked Pawl™ technology of GearWrench **120XP** ratchets gives you 120 positions in every full turn and a super-tight 3° swing arc to turn bolts where others can't. With legendary GearWrench® speed and strength, they're seriously productive tools.

From the leader in hand tool innovation, our best ratchets yet.

 **GEARWRENCH**®

GET IT DONE.™

Visit us at ISN booth # 1222

Enter 20 at "e-inquiry" on [VehicleServicePros.com](http://VehicleServicePros.com)

\*Results based on manufacturer test of 3/8" drive 120XP ratchet.

©2013 Apex Tool Group, LLC  
[www.gearwrench.com](http://www.gearwrench.com)



Find us on Facebook  
[www.facebook.com/gearwrench](http://www.facebook.com/gearwrench)

## COVER STORY/DISTRIBUTOR PROFILE



**A customer examines a Genisys diagnostic tool that Clint Maxwell has lent him to use on a trial basis.**

“The easiest way to make sure you get paid is call their mother,” he says. “Guys don’t want to look bad,

especially to their mother.”

He also visits spouses at work to pass the message along. “No one

(spouse) wants to be married to a loser,” he says.

Maxwell says it’s important not to invest too much emotional energy in skips. “You do your best to chase them down, but you don’t get consumed by it,” he says. “It will eat you.” This, in turn, will affect how you treat other customers.

### Outlook positive

Maxwell is optimistic about the future of his business. One reason is the tool manufacturers keep coming up with new and better products.

He recently learned that metric tools are popular with some customers. He has noticed that a lot of his technician customers need specialty tools for work they do around the house and in their own garage. “They have ‘standards’ at work and metrics at home,” he notes.

*(Continued Page 18)*

## INCREASE SALES AND PROFITS SIX WAYS

- Hansen Socket Trays straighten out toolbox clutter and chaos.
- Patented socket trays provide easy access and organization for individual sockets.
- Post bases are beefed up and designed to hold sockets more securely.
- Made of tough ABS plastic that resists gas, oil and abuse.
- Trilingual Packaging for both SAE and METRIC.
- Lifetime Warranty.



**Innovative Tools That Really Work**



MADE IN U.S.A.

## Hansen Trays Now available in 3 pc. sets!



Part #9301  
Trays come in SAE and Metrics sizes for 1/2", 3/8" and 1/4" drives



Part #9302  
Trays come in SAE and Metrics sizes for 1/2", 3/8" and 1/4" drives

251 Taylor Street / Two Rivers, WI 54241 / 920.793.5213 / [www.hansenglobalinc.com](http://www.hansenglobalinc.com)

Enter 21 at "e-inquiry" on [VehicleServicePros.com](http://VehicleServicePros.com)



# IT'S ALL ABOUT SERVICE



**OVER  
8,000  
ITEMS**

- ✓ **3 NORTH AMERICAN WAREHOUSES**
- ✓ **95% FILL RATE**
- ✓ **OPEN STOCK**
- ✓ **EXCEPTIONAL VALUE**
- ✓ **LIFE TIME WARRANTY**
- ✓ **OVER 40 YEARS IN THE TOOL BUSINESS**

Official Tool of NHRA Top Fuel Driver, Terry McMillen



Enter 22 at "e-inquiry" on [VehicleServicePros.com](http://VehicleServicePros.com)

**Contact us. | 909-230-9588 | [www.geniustoolsusa.com](http://www.geniustoolsusa.com)**

## COVER STORY/DISTRIBUTOR PROFILE

He has also noticed that diagnostic tools have become popular as of late, as have cordless tools with longer-lasting batteries.

One of the things he likes best about the job is there is always something new to learn. "Cars change and technicians change," he says.

While the market is still challenging because of the recession, Texas has fared better than most regions, largely on account of the energy industry. Some of Maxwell's best accounts are shops that service oil and gas fields.

He is also grateful to have a supportive wife, both morally and financially. His wife recently took a job as a full-time nurse, allowing Maxwell to pay more of his debt.

He has already paid off about half of his business debt. He next hopes to buy a new truck and install ISN business



*A customer examines various pliers on the truck.*

software. With more tools to display and automated business management, he thinks he will be able to increase his sales significantly.

Looking to the future, he would like to see independent distributors pool their resources for buying and warehousing. ■

**Roll with Pride**  
**Carry the Tools 100% Made in the USA**

- Carry the Trusted Name
- Highest Quality Tools
- 100% Made in the U.S.A.
- Superior Value
- Limited Lifetime Warranty
- 98% Shipping Performance

Your target customers may not know some of the tools from their long trusted brands are not made in the USA anymore. You've built your business being the pro that the pros trust. With S•K you represent a full line of superior quality tools, manufactured entirely in the United States to meet or exceed every industry quality-control benchmark. Coupled with a 98% shipping performance record and a Limited Lifetime Warranty, S•K Professional Tools are an outstanding value and the ultimate loyalty builder. That's not just any tool you're selling. That's the power and precision of a professional grade tool made in the USA, made by SK.

*We proudly stamp USA onto every tool we make...because we can.*

Made in U.S.A. To learn more go to [skhandtool.com](http://skhandtool.com) or call 1-800-822-5575

**SK**  
PROFESSIONAL TOOLS

Enter 23 at "e-inquiry" on [VehicleServicePros.com](http://VehicleServicePros.com)

# myMoney

## Business Management Solution

We are happy to announce the development of **myMoney Suite** for **iOS devices**.

Sync with your myMoney Customer & Product data bases and enjoy the freedom that comes with a mobile Point of Sales system.

All business transactions and edits on your app sync back to your myMoney Suite software. All you need is a working wi-fi or internet connection.

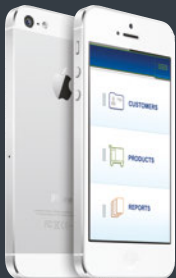

### FEATURES

- Sell & Collect
- Signature catching
- PayPal compatible
- Made for iPhone & iPad
- Invoices via email or print
- Accept multiple forms of payment
- View & edit Customers and Products



[myMoneySuite.com](http://myMoneySuite.com)

# myMoney

**Business Management Solution**

## **Will you be attending ISN Tool Show 2013?**

When you sign up for myMoney Suite at the show, you also receive a FREE MONTH of Hatala Support Services.

Think of it as your own personal IT Department. Whether it is a business or home related computer issue, Call Hatala and we'll take care of you.

### **How does it work?**

After setting up myMoney Suite for you, your support tech will run a quick systems check and diagnosis of your computer systems. This means you won't have to worry about your computer being vulnerable or unreliable. Your tech will also give you more information about all the services and features that come with Hatala Support Services.



**CallHatala.com**

**myMoneySuite.com**

# Learn **how to make your business** more efficient and profitable

**REGISTER NOW  
TO UNLOCK  
EXCLUSIVE  
CONTENT!**



*PROFESSIONAL DISTRIBUTOR* magazine has designed a special section of the VehicleServicePros.com website just for you — the mobile distributor! Articles exclusive to your industry are housed in a special section of the website to keep private from the public, and are only tailored to mobile distributors with a unique login.

Once you register for your unique login, discover how other distributors are running their businesses, view photo galleries of different truck layouts, receive useful sales

strategies; learn new technical information and much more!

It only takes a few minutes to register and verify your credentials. Register only once and simply use your login information when you return.



**REGISTER TODAY  
TO UNLOCK THE CONTENT!**

Go to: [VehicleServicePros.com/10878334](http://VehicleServicePros.com/10878334)

**PROFESSIONAL DISTRIBUTOR**

**VEHICLESERVICEPROS.com**

## SPECIAL FEATURE

# Vehicle maintenance tips for “summerizing” trucks

Examine the engine coolant, electrical systems and batteries to ensure your truck is running efficiently during the summer months.

By David A. Kolman, Contributing Editor

**T**aking care of your truck during the summer months is just as important as it is in the winter. Like cold weather conditions, summer's hot and dry weather causes additional stresses on vehicles as well.

Because of the higher temperatures, the cooling system is required to work harder in the summer to keep the engine from overheating. If it is not maintained properly, the engine will not operate as efficiently and internal components could be damaged.

Inspect the radiator inside and out for signs of damage.

Make sure the cooling system is full and look to see if the coolant is clean and pure, with no rust

or other impurities, as these can contaminate the cooling system and cause costly issues.

Examine the radiator cap for cracks and/or swelling and replace if necessary.

Check the cooling fan for loose or damaged fan blades.

Check hoses and lines for excessive mushiness and hardness, cracks and leaks and other signs of deterioration. Be sure all connections are tight to avoid leakage.

*An effective cooling system additive can promote long-term system function by inhibiting the formation of rust and scale, neutralizing pH imbalance and controlling electrolysis.*



*Tired of charge and retest messages?*

## Carbon Pile Load Testing... Still “The Gold Standard” For Battery Testing



Made in USA

**ASSOCIATED**

**800-949-1472**  
[www.associatedequip.com](http://www.associatedequip.com)



**65th Anniversary Contest**  
Scan code or go to  
[www.associatedequip.com/contest/](http://www.associatedequip.com/contest/)  
for entry details.

Made in America,  
**Cutting-Edge  
Technology**  
*for 65 years!*

Enter 24 at “e-inquiry” on [VehicleServicePros.com](http://VehicleServicePros.com)

## SPECIAL FEATURE

Inspect all belts for wear and tension. Using and maintaining a properly formulated coolant prevents rust, dirt, scale and other contaminants from creating engine-damaging "hot spots" in a vehicle's cooling system.

It is advisable to do an engine coolant analysis. This not only determines coolant

**Coolant test strips can be used to determine if cooling system service is required and if the coolant is ready for the summer heat.**

condition and additive concentrations, it also identifies other vehicle problems that can show up in the cooling system.

Examine the electrical wiring to make sure wires haven't come loose. Be on the lookout for frayed or cracked insulation and for rubbing against any abrasive items. Also look for signs of corrosion. Make any necessary repairs.

Check starter and alternator connections and ground wires to ensure that all connections are both clean and tight.

Batteries need additional attention because battery degradation occurs much more rapidly in hot weather.

Check the batteries to see if the cases are bulging, cracked or leaking and to be certain they are firmly mounted in place.

Examine the integrity of the battery cables where they connect to the battery and make sure the fasteners are secure.

Inspect the battery cables to assure they aren't in contact with items that will wear through their insulation. ■



**Style. Fit. Function.**

All three basic elements in the new NASCAR® 427™ that is as thrilling as your favorite NASCAR® race series! The NASCAR® 427™ is tested to meet ANSI Z87.1-2010 and CSA Z94.3-2007.

Learn more at [www.enconsafety.com/427](http://www.enconsafety.com/427)

**Encon®**  
SAFETY PRODUCTS

Like us on Facebook

Encon® is a registered trademark of Encon Safety Products, Inc. Houston, TX.  
NASCAR® is a registered trademark of the National Association for Stock Car Auto Racing, Inc.

Enter 25 at "e-inquiry" on [VehicleServicePros.com](http://VehicleServicePros.com)

Professional Distributor / June 2013 / [www.VehicleServicePros.com](http://www.VehicleServicePros.com) / 21

## How to stock the right inventory

BY PHIL SASSO, CONTRIBUTING EDITOR



Phil Sasso is president of Sasso Marketing Inc. ([www.sassomarketing.com](http://www.sassomarketing.com)), a technical marketing agency specializing in tools and equipment. Subscribe to his free marketing tips at [philsasso.com/blog](http://philsasso.com/blog).

**Q** I've been a tool guy for several years. When it comes to inventory, I still sometimes struggle. I have some stuff that sells out too quick and other stuff that gathers dust. Any advice on managing inventory?

**A** You're better off with an empty shelf than a shelf full of items that won't sell. Who wants to tie up money in slow-moving inventory?

This is one reason it's a good idea to develop tight relationships with one or two customer service representatives (CSRs) at your flag and warehouse distributor. Those people can be key to your success in selecting the right products and the right number of products. Don't think of the CSRs as just order takers.

Build rapport with them. As they get to know you and your buying patterns, they can also offer advice and help you sort through their lines.

"When you look at 500 manufacturers, it can be overwhelming. But that's why our sales team members are there to help," says Scott Pilkenton, national sales manager for Integrated Supply Net-

**THOSE PEOPLE (CUSTOMER SERVICE REPS) CAN BE KEY TO YOUR SUCCESS IN SELECTING THE RIGHT PRODUCTS AND THE RIGHT NUMBER OF PRODUCTS.**

work Inc. (ISN). "They can tell you what's hot and point out what's just arrived," Pilkenton says. "If we get in something today, it will be on our website by 12 a.m. tomorrow."

Your CSR can tell you what is selling well nationwide and in your particular area and can help you gauge what to buy and how much. The good CSR is there to help you increase your turns, not just

stock your shelves. The more you sell, the more they sell. It's a win-win.

"What we don't want to do is over-stock somebody," explains Pilkenton. "We know that we want them to turn their inventory, so they're keeping really fresh products. When we have other hot new products come in, we don't want their 'open to buy' to be totally obliterated. We want to make sure we're working with them to stock the correct items."

If you find yourself stuck with dust collectors, check out the return policy. It's often better to pay to ship products back than to slash prices below your cost - especially if there's no or a low restocking fee.

**Q** I'm a newbie franchise dealer. I'm not an independent, so is there any reason I need to sign up with a wholesale distributor? What are the advantages and disadvantages to buying out of program?

**A** You can't sell what you don't carry.

You need quick access to anything a customer might request. So, when your main supplier is out-of-stock or doesn't carry an item your customer wants, you need at least one alternative supplier you can depend on.

The breadth of product of a good wholesale distributor can help you fill out your inventory, fill some franchise back orders and keep you filled-in on new products.

Another benefit of working with a wholesale distributor is access to more discounts. A popular item may be on special this month with your wholesale distributor that's not in your flag's monthly promotion. So by having a good back-up supplier, you can in essence double the specials you can offer your customers.



Having a well stocked truck such as this is key to success in tool sales, providing the inventory turns.

CONTINUED PAGE 24

## 13801: IP54 INFRARED THERMOMETER



- IP54 Splash proof certification
- 12:1 distance/spot ratio
- Min/Max, diff and lock
- Backlit display
- -76°F to 1022°F

## 13804: CAT IV DIGITAL MULTIMETER



- Cat IV 600V/Cat III 1000V for HEV work
- High accuracy standard DMM
- Fuel injector pulse width testing
- RPM measurements with included inductive pick-up
- Limited Lifetime Warranty

## 13805: AUTOMOTIVE DUAL CHANNEL SCOPE



- 8 Pre-Set Waveforms
- TRMS Graphing Multimeter functions
- "Glitch Snare" mode
- Component Test Modes
- 1 μs – 50 second sweep mode
- Inductive pickup/thermocouple probe/ test leads/carrying case

## 13808: CAT IV CLAMP-ON METER



- 750V AC & 1000V DC tests
- 600A current range AC / DC
- Backlit Display & Worklight
- Magnetic Mount and Lead Storage
- Non-Contact Voltage Tester

## TU-470B: FUEL INJECTION CLEANER



- Two gauges enable a technician to check the vehicle fuel pressure with the left gauge, and then easily set cleaning pressure with the top gauge by referring to vehicle fuel pressure on the right gauge
- Cleans carbon from intake valves, fuel passages, and cylinders with a professional carbon cleaning solution, which will restore the original spray pattern more effectively, giving improved performance, fuel economy, and emission tests

## TU-443: DELUXE FUEL INJECTION PRESSURE TEST SET



- The included adapters, hoses, and fittings cover most fuel injection systems worldwide
- A time-saving quick coupler connection at the end of the gauge hose makes a speedy and efficient coupling possible with the adapters
- Adapters will work with Lang TU-470B for full range of coverage

## CLT-2: CYLINDER LEAKAGE TESTER



- This tester measures the ability of an engine cylinder to hold compressed air using shop air pressure and supplements a compression tester
- The 2-1/2" special gauge has one multicolored band for measuring low, moderate and high leakage, and a scale range from 0-100%. The second gauge is 2-1/2" and has a dual scale dial PSI and bar, which allows the technician to monitor input air-line pressure

Visit us at ISN booth # 714

## TU-30A: COMPRESSION TESTER SET



- Tests compression on most domestic and foreign cars, and light trucks with gasoline engines, including mini engines
- Set includes: 200 PSI gauge, 1-1/2" PSI gauge (14mm & 18mm thread) for small engine testing, short 14mm hose assembly, long 14mm hose assembly, 12mm & 16mm hose assembly, 10mm short thread adapter, 24" hose assembly with quick coupler, 300 PSI 68mm gauge and hardware assembly



## SALES Q & A

The obvious downside to buying outside of a franchise program is that you risk violating your franchise agreement. So be sure you read it carefully and talk to your flag district manager so you know what is and what's not acceptable.

**Q** What is the best way to handle special orders? How can I deal with price inquiries without wasting a lot of time? Is drop shipping a good idea?

**A** Special orders can be a bit of a hassle. But it can be worth a few minutes of your time to turn a special order into a stronger relationship with your customer.

Special order pricing lookup isn't the issue it once was. Your point-of-sale system should do special order price

lookups in seconds. So, you can quote a price, close the deal and collect a deposit on the spot. Some suppliers allow subscribers to text a part number and get back pricing and availability in a matter

**IT CAN BE WORTH A FEW MINUTES OF YOUR TIME TO TURN A SPECIAL ORDER INTO A STRONGER RELATIONSHIP WITH YOUR CUSTOMER.**

of seconds so a dealer knows immediately if he's placing an order or back order.

A bigger issue can sometimes be figuring out exactly what a customer wants if he or she can't give enough specifics. One dealer told me he once asked if

anyone else in the shop had the tool so he could find a part number or at least a manufacturer's name. It worked!

Lastly, drop shipping is no longer a dirty word. It was once unthinkable to drop ship a special order or out-of-inventory item directly to your customer. Now, I think it's just good business. Many suppliers ship packages without their address or prices on the packing slips.

Many suppliers can ship the same day if orders are received by mid-afternoon. If you call an order in by 3 o'clock today, it ships same day, says ISN's Pilkenton. "We service over 80 percent of the entire U.S. next day," he notes.

So in most case, your customer doesn't have to wait a week or two for you to get back to him with his new tool. This makes for happier customers. And happier customers tend to make for happier dealers. ■

### FORD POWER STROKE 6.7L DIESEL INJECTOR SOCKET

**11400**



### BMW INJECTOR PULLER

**11800**

- Compact slide hammer design is necessary on V-8 applications
- Quicker than using the factory tool that needs to be worked down and around the injector.
- On the 8 cylinder V-8 4.4 liter turbo (N63) the tool will pay for itself on the first job.
- Makes removal of injectors on 6 cylinder faster and easier.



**CHECK OUT THE VIDEOS ON  
[www.youtube.com/schleytools](http://www.youtube.com/schleytools)  
CONTACT [www.sptool.com](http://www.sptool.com) OR CALL 714 693-7666**

Enter 27 at "e-inquiry" on [VehicleServicePros.com](http://VehicleServicePros.com)

Visit us at ISN booth # 740

# MULTIBRAND COVERAGE MULTISYSTEM SOLUTIONS

**jaltest** *Diagnostics*

- ✓ J1708 / J1939 STANDARDS SUPPORTED
- ✓ ONE YEARLY LICENSE. ALL HD, MEDIUM & LIGHT DUTY BRANDS & MANUFACTURERS
- ✓ TECHNICAL INFORMATION & WIRING DIAGRAMS INCLUDED
- ✓ PROPRIETARY FAULT CODES AVAILABLE (PPID - PSID)
- ✓ SPECIFIC DIAGNOSTIC FUNCTIONS
- ✓ AVAILABLE TROUBLESHOOTING GUIDES
- ✓ BI-DIRECTIONAL CONTROLS
- ✓ TRAINING AND PRODUCT SUPPORT



**GO BEYOND DIAGNOSTICS**

[www.jaltest.com](http://www.jaltest.com)



**cojali**  
USA

COJALI USA Inc. / 7855 N.W. 29th Street, Suite 190 Doral, Florida 33122, USA  
305.960.7651 | [info@cojaliusa.com](mailto:info@cojaliusa.com) | [www.jaltest.com](http://www.jaltest.com)

**Drive with us**

Enter 28 at "e-inquiry" on [VehicleServicePros.com](http://VehicleServicePros.com)

# MOST WANTED

## Do YOU stock it?

The following products are among the most requested tools and equipment from recent issues of *PD's* sister publication, *Professional Tool & Equipment News*.

Perhaps you've already received requests about some of these items. They are definitely products you should take a closer look at stocking for your customers. ■



### Install Euro rims more quickly and easily

Lock Technology's LT465 12mm and 14mm Wheel Hanger Guides slide into wheel lugnut holes without using threads, saving the technician time because they involve no turning the wheel guide to install and remove. Wheel hanger guides support the wheel/tire so the technician can

easily thread lugnut bolts into the brake rotor and avoid dropping the tire or having the outside section of the rim hit the floor and scratch. The tool comes made of durable, bulletproof polycarbonate plastic. This tool works on Mercedes, Audi, BMW, Mini Cooper, Saab and Volvo vehicles. Each kit includes one 12mm and one 14mm wheel hanger guide. Enter 29 at "e-inquiry" on VehicleServicePros.com

### Cut through metal

Campbell Hausfeld's plasma cutter, No. WK2500, comes as a 120V input, 13-amp DC output with inverter technology to produce a lot of power from a 22-lb package. The tool features a professional torch with contact striking pilot arc for distortion-proof cutting of mild steel, stainless steel, aluminum, copper and brass. For safety it includes an error indicator light for faulty connections, thermal overload protection with automatic shut-off and a built-in regulator and gauge for in-bound compressed air.

Enter 32 at "e-inquiry" on VehicleServicePros.com



### Service alternator decoupler pulleys

Lisle's alternator decoupler pulley tool kit, No. 57650, removes and installs many alternator decoupler pulleys found on the most popular vehicles in North America. The company recommends considering replacing alternator pulleys whenever selling a belt. It works on both OAD (overrunning alternator decoupler) and OWC (one-way clutch) pulleys. This kit includes: 33T spline pulley socket, 17mm hex pulley socket, 10mm triple-square-shaft bit, T-50 shaft bit and 10mm female-hex-shaft bit. The tool works with the wrenches and sockets technicians already own.

Enter 33 at "e-inquiry" on VehicleServicePros.com



### Brake spring pliers

V8 Tools offers the V8-989 Brake Spring Pliers. In addition to including a pair of end cutters, V8 improved the tool by making it longer with wider and stronger tips that can hold the spring better without leaving deep cut marks. This tool makes a normally frustrating job quick and easy.

Enter 30 at "e-inquiry" on VehicleServicePros.com



### Extract and add fluid

CTA Manufacturing's extraction/filling syringes, Nos. 7075 and 7077, can handle all automotive fluids, including brake fluid. This syringe disassembles for easy cleaning and comes with a spring-loaded, detachable tube. The body includes benefits such as being dual-calibrated and is clear for easy viewing. The No. 7075 provides a 200cc capacity and the No. 7077 has a 1500cc capacity.

Enter 31 at "e-inquiry" on VehicleServicePros.com



### Standard and deep, fractional & metric socket set

The SK Hand Tools 49-Piece 3/8" Drive 6-Point Standard and Deep, Fractional and Metric Socket Set with Universal Joint, No. 94549, is made in the U.S.A. and features quality workmanship. High polish SuperKrome plating results in a jewelry-like finish, providing long life and maximum corrosion resistance. It's packaged in a molded plastic case.

Set contains:

- 7-1/2" professional ratchet.
- 1-1/2" professional thumbwheel ratchet.
- 3" and 6" extensions.
- Universal joint.
- 1/4", 5/16", 7/16", 1/2", 9/16", 5/8", 11/16", 3/4", 13/16", 7/8" standard sockets.
- 3/8", 7/16", 1/2", 9/16", 5/8", 11/16", 3/4", 7/8" deep sockets.
- 6mm, 7mm, 8mm, 9mm, 10mm, 11mm, 12mm, 13mm, 14mm, 15mm, 16mm, 17mm, 18mm, 19mm Standard Sockets.
- 10mm, 11mm, 12mm, 13mm, 14mm, 15mm, 16mm, 17mm, 18mm, 19mm deep sockets.

Enter 36 at "e-inquiry" on VehicleServicePros.com



### Ignition spark tester

The Thexton Manufacturing THX404 Adjustable Ignition Spark Tester works on ignition systems from high-energy electronic automotive systems to small engines. This tool tests for no-start conditions and for spark strength. An adjustable gap allows for spark gap requirements from no volts to 40,000V. Gauge background makes the spark easy to see for accurate measurement. The alligator clip securely fastens to ground. The screw assembly adjusts spark gap quickly and easily.

Enter 34 at "e-inquiry" on VehicleServicePros.com

## MOST WANTED



### Remove GM thermostats easily

Cal-Van Tools' GM Thermostat Wrench, No. 751, can work on GM 3.1L and 3.4L V6 engines. Thermostat replacement forces the technician to remove the thermostat housing. In these applications, the bottom housing bolt is almost inaccessible without removing other parts, until now. The wrench with its unique shape and design allows users to remove and install the housings in a fraction of the time it currently takes. The wrench is a 13mm, 12 point with special bends specifically for GM V6 thermostat housings.

Enter 37 at "e-inquiry" on VehicleServicePros.com



### Make a perfect welded butt joint

Dent Fix's Butt Welding Clamps, No. DF-BC200, provide a simple and efficient way to ensure the perfect welded butt joint. The pack of four clamps holds two panels of dissimilar thicknesses, edge to edge with almost no gap. The level adjusts between 0mm and 3mm, allowing flat alignment of the top or bottom surface panels.

Enter 38 at "e-inquiry" on VehicleServicePros.com



### Fix air conditioning leaks

The AGS Company Swedge-Lok Repair System makes air conditioning leak repair easy by eliminating the need to wait for expensive OE replacement parts. It requires no welding or soldering and saves time by allowing most repairs right on the vehicle. The Swedge-Lok and Swedge-Lokr provide universal repair of air-conditioning tube and hose connections in all makes and models of vehicles. All Swedge-Lok unions use the company's aluminum alloy, making them corrosion-proof for a true permanent repair. The unique design and strict tolerances of each union assures that each repair is pressure-rated and tested to 1,000 psi, exceeding all requirements for air conditioning systems.

Enter 35 at "e-inquiry" on VehicleServicePros.com



# 2013 PTEN Innovation Awards Winners

**M**ay we present to you: the 2013 PTEN Innovation Award product winners! This year competition was fierce, as we received over 80 product nominations, spanning 25 different product categories. Throughout the next few pages, you'll find the product that took top honors in each category.

To review all of the nominees, check out the April and May issues of *Professional Tool & Equipment News*, or go online to [VehicleServicePros.com/2013IANominees](http://VehicleServicePros.com/2013IANominees). We'll be holding the annual awards ceremony on the show floor of the AAPEX Show in Las Vegas this November. Look for more coverage of the 2013 PTEN Innovation Awards and the AAPEX Show this fall.

**COMPANY: LINCOLN INDUSTRIAL**

**PRODUCT: 18V LITHIUM-ION POWERLUBER GREASE GUN**

The innovative design of the Lincoln 18V Lithium-ion PowerLuber grease gun incorporates outstanding run-time, output pressure and grease flow, as well as a multi-function LCD that displays quantity of grease dispensed, quantity of grease remaining in the cartridge, battery charge level, operation signal and stall indicator.

The PowerLuber allows the user to monitor grease output for extended equipment life while saving lubricant and improving run-time. The display is simple to understand and can be reset easily between lube points. The cartridge level display helps to prevent the user from getting caught in the field without grease.

This cordless tool also features an LED on the front of the gun to shine light on grease points in shaded areas, under equipment or when lubing early or late in the day. Its high-amperage, lithium-ion technology provides fade-free delivery and outstanding run-time while offering three times the lifespan of NiCd batteries.

**CATEGORY: OIL & LUBE**  
Enter 39 at "e-inquiry" on [VehicleServicePros.com](http://VehicleServicePros.com)



**COMPANY: ACDELCO**

**PRODUCT: ARI2044B LI-ION 18V 3/8" ANGLE IMPACT WRENCH WITH DIGITAL CLUTCH**

The ACDelco ARI2044B Li-Ion 18V 3/8" Angle Impact Wrench with Digital Clutch is an innovative angle impact wrench that is built with motor technology, delivering maximum reverse torque of 95 ft/lbs and maximum tightening torque of 60 ft/lbs.

The ARI2044B provides a variable speed control of 0-2,000 RPM and no load speed of 0-3,000 impact per minute (IPM). The 90-degree right angle design allows for tight space access.

The Digital Clutch ensures the tool automatically stops at predefined (user set) settings, ensuring bolts are not over-tightened. Using a digital sensor rather than mechanical, the accuracy is maintained throughout the battery cycle.

The package includes: two rubberized Li-ion 18V 2.0Ah battery packs, one 30-minute intelligent fast charger and a carrying case. Chargers utilize a patented, air-forced technology which forces air through the battery to cool it while charging it, allowing for much faster charging times.

**CATEGORY: POWER TOOLS**  
Enter 41 at "e-inquiry" on [VehicleServicePros.com](http://VehicleServicePros.com)



**COMPANY: AESWAVE**

**PRODUCT: UACTIVATE ULTIMATE CIRCUIT BREAKOUT BOX**

The AESwave uActivate Ultimate Circuit Breakout Box makes it easy to connect test equipment to complete voltage, current and resistance tests.

Connect the uActivate to the circuit – only one connection to the circuit required. It is now easy to connect a lab scope, digital multimeter as well as an amp probe to the ports on the uActivate. The innovation of this product helps users with circuit testing through the relay socket, through the fuse, through a connector – the user is in control (of when the circuit turns on); flip the switch and uActivate the circuit on demand. This uActivate features updates to the internal circuitry, and comes with an added universal cable kit and adapters. This tool also features LED indicators to quickly identify when voltage is present. It simultaneously performs circuit voltage and current tests using a lab scope or inductive current clamp, and the ability to monitor voltage to determine if any voltage drop exists.

**CATEGORY: DIAGNOSTIC TEST EQUIPMENT**  
Enter 40 at "e-inquiry" on [VehicleServicePros.com](http://VehicleServicePros.com)

PPH1 • PP319FTC • ECT2000 • BAKIT01 • PPKIT03

5 Ways to be more

# Profitable

Power Probe has always worked with Technician's and pride ourselves in the way we are passionate about our tools and the service we provide. These 5 products were created by listening to the automotive Tech that works on vehicles all day, everyday!



### BAKIT01

Power Probes Professional Leak-proof Master Cylinder Adapters are made from aluminum and color coded. All use standard couplings.

### The Complete Circuit Testing Solution



### PPKIT03

This Master Kit has the ECT2000 and the PP3, plus our full Lead Set.

### PP319FTCRED

The Power Probe 3 is truly the Workhorse of all circuit testers! It has bright white LED headlights, Volt meter, Min/Max mode, Audible Monitoring, tests Continuity, indicates Shorts and Opens and much more...



### PPH1

The HOOK by Power Probe features the Hot Shot® Mode with "Pass" or "Fail" readings when load testing power and ground connections. The Smart Tip Advantage chooses the correct Meter and Range. Diagnose and Compare Voltage readings instantly making a Voltage drop test as simple as probing a wire or connector.



**Powers Up High Current Components**

### PPECT2000

The "SMART" ECT2000 actually points in the direction of the Short Circuits and alerts you when you get there! It can detect through plastic and dry carpets eliminating the time consuming removal of panels and carpets.



www.powerprobe.com

800-655-3585

Please follow us on:    

**The Ultimate in Circuit Testing**

Enter 42 at "e-inquiry" on VehicleServicePros.com

Visit us at ISN booth # 1102



**COMPANY: SNAP-ON EQUIPMENT**

**PRODUCT: INTEGRITY TEST DRIVE**

The Integrity Test Drive by John Bean is a unique system that performs a complete vehicle inspection in a matter of minutes, including alignment, battery, brake efficiency, brake pad thickness and diagnostic codes, and it generates specific reports that highlight the results of each inspection. The vehicle condition report documents the inspection and helps the service advisor communicate the needed services to the customer. The Integrity Test Drive combines several productivity-enhancing products that work together, giving technicians the ability to quickly inspect more vehicles as well as to provide customers with a complete health snapshot of their vehicle, identifying needed service and repair opportunities. The Integrity Test Drive is a "must have" for shops that want to fully optimize their repair capacity and vehicle throughput.

**CATEGORY: SHOP EQUIPMENT**  
Enter 43 at "e-inquiry" on VehicleServicePros.com



**COMPANY: KNIPEX TOOLS**  
**PRODUCT: TWINFORCE**

The KNIPEX TwinForce is the first major advancement in cutting pliers since KNIPEX invented the high-leverage pliers many years ago. The TwinForce produces the cutting power of a 10" pliers in a compact 7" tool, cutting 50 percent easier than comparable 8" pliers, according to the company. A compact pliers that cuts heavy duty wires is a significant advantage to the automotive technician since the workspace under the hood continues to get tighter. In addition to big-time cutting, the KNIPEX TwinForce fits great in the hands of technicians with physically large or small hands. The KNIPEX TwinForce employs a twin-hinged joint design, giving the tool a superior solid feel and the ability to do rough and fine work with the same pliers. In use, the double-hinged joint allows the user to cut unusually large or hard wire with a second or third cut as the jaws "open up" to accept large items.

**CATEGORY: HAND TOOLS**  
Enter 44 at "e-inquiry" on VehicleServicePros.com



Looking for an inexpensive way to get your customer into Launch's next generation software suite?

Look no further. **Introducing The X-431 IV.**

- > **NEW** sleek & rugged design
- > **NEW** rotating cable port for increased mobility around the vehicle
- > **NEW** faster processor for immediate boot-up & quick navigation
- > OEM-Level European, Asian & Domestic coverage
- > Access ECM, PCM, BCM, ABS, SRS, A/T & More!
- > Domestic OE functions - Ford: access to more modules for coding on F-Series Super Duty, Explorer & F-150s, Chrysler: CVT initialization, ECM replacement coding along with DPF regeneration/replacement function
- > Adaptive Resets, Service Reminder Resets & Relearns
- > Comprehensive Bi-directional testing capabilities
- > View, graph, record, & print live data
- > One year of FREE software updates
- > Supports all test modes of OBDII
- > Touch screen user interface



MSRP: \$1,595.00

**LAUNCH**

The Global Leader In Diagnostics

Connect With Launch:



www.launchtechusa.com • 1-877-LAUNCH9

Enter 45 at "e-inquiry" on VehicleServicePros.com

Visit us at ISN booth # 432

## WINNERS

### COMPANY: SNAP-ON

#### PRODUCT: WIRELESS DIGITAL INSPECTION SCOPE



With a larger video screen and more memory, the BK8000 Wireless Digital Inspection Scope is the latest addition to the Snap-on line to make work easier. The BK8000 brings increased visibility to under dash, inside door panels, under hood, behind the engine block, within transmission housings, inside the engine and other work not easily accessible by the technician. The dual imager further improves the ability to diagnose problems by allowing for straight-ahead or 90-degree angle viewing. Features and benefits include:

- A 4.3" diameter screen 40 percent larger than competitive units, according to the company, for better viewing.
- Digital video and image capture with internal memory and SD card storage.
- Dual imager allowing technicians to see straight ahead or at a 90-degree angle.
- Wireless 802.11n provides clear image transmission.
- Touchscreen interface enables easy feature selection.
- Three-mega-pixel, rear-view camera allows the technician to document pre-service vehicle condition.

**CATEGORY: INSPECTION TOOLS, LAB SCOPES**

### COMPANY:

#### NEW PIG CORP.

#### PRODUCT: PIG BATTERY ACID SPILL KIT IN SEE-THRU BIN

New Pig Corp. offers the PIG Battery Acid Spill Kit In See-Thru Bin for neutralizing and cleaning up battery acid spills quickly.

Ideal for maintenance and storage areas, the PIG Battery Acid Spill Kit contains PIG socks, loose absorbents and wipers formulated specifically for neutralizing and cleaning up battery acid. The kit also includes personal protection equipment (PPE), including a full-face shield.

The kit's see-through container allows for quick inventory inspections and features built-in handles for grab-and-go spill response. Easy to store, the PIG Battery Acid Spill Kit In See-Thru Bin fits on a shelf and can also be mounted to a wall.

**CATEGORY: SAFETY EQUIPMENT**

Enter 46 at "e-inquiry" on [VehicleServicePros.com](http://VehicleServicePros.com)



### COMPANY: SNAP-ON

#### PRODUCT:

#### RECHARGEABLE LITHIUM-ION WORK LIGHT

Versatility defines the Snap-on Rechargeable Lithium Ion Work Light (No. CTLED7850), making it useful in multiple settings and applications. This innovative 18V light features a unique dual beam reflector system that easily changes from a "spot style" beam reflector that concentrates the brightest portion of light near the center of the beam pattern, to a second "flood style" beam reflector for applications that may require illumination over a larger area.

The Lithium-ion light has a cast aluminum head for durability and pivots 120 degrees for ease of use. A high capacity LED delivers a category leading 300 lumens of brightness.

**CATEGORY: LIGHTING**



 **Chicago  
Pneumatic**

# Superior Innovation



1/2" Impact Wrench

## CP7759Q

## Put Comfort in Your Customer's Hands

- Maximum Ergonomics and Well Balanced
- Light Weight Carbon Fiber Design - 3.7lbs.
- Max Working Torque: 780 ft-lbs.
- Twin Hammer Clutch Mechanism for Greater Durability and Power Transfer
- Full Teasing Trigger for Greater Control
- Features Single Handed Side to Side Forward / Reverse for Easy Operation
- 2 Year Limited Warranty

Scan the code to see the  
video and specifications



Visit us at ISN booth # 214

Enter 47 at "e-inquiry" on [VehicleServicePros.com](http://VehicleServicePros.com)

[www.cp.com](http://www.cp.com) People. Passion. Performance.



**WINNERS**

**COMPANY:**  
**LINK NEW TECH**  
**PRODUCT: PXA9**  
**TRANSMISSION FLUSH**

The fully-automatic, patented Power Xtreme Quick Transmission Fluid Changer from Link New Tech is the latest technology in ATF changing machines. It is able to exchange ATF directly from the transmission fill tube without any mechanical pumps or bladders and in under 10 minutes. The PXA9 is designed with a 10-gal capacity and special see-through tanks. It can be used on cars, trucks and SUVs. It is fast and easy to use, keeps a shop work floor clean and is environmentally safe. It has no hazardous chemicals for the technician to come in contact with. All Power Xtreme machines are under 99 lbs to save on heavy duty construction, with fiberglass tanks, and one-year warranty.

**CATEGORY: FLUID EXCHANGE**  
Enter 48 at "e-inquiry" on VehicleServicePros.com

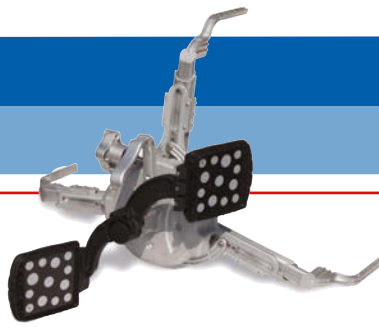

**COMPANY: SNAP-ON EQUIPMENT**  
**PRODUCT: JOHN BEAN AC400 TOUCHLESS**  
**ALIGNMENT WHEEL CLAMP**

The John Bean AC400 Touchless Wheel Clamp allows service technicians to secure clamping of the tire without touching the rim. The AC400 is fast and easy to use as clamping is accomplished with a single, fast-action adjustment knob which adjusts to the full range of tire sizes in just a few turns. Clutch limited clamping force ensures accurate and repeatable results.

With its patented self-centering design, the John Bean Touchless Alignment Wheel Clamp allows measurement of cross diagonal and tire rolling radius to reveal collision damage and mismatched tire sizes. The durable and drop-tested, cast magnesium construction eases the weight users have to carry. The AC400 also features a large, comfortable handle that is easy to operate and accommodates gloved hands.

**CATEGORY: TIRE, WHEEL SERVICE**  
Enter 49 at "e-inquiry" on VehicleServicePros.com

**COMPANY: SNAP-ON**  
**PRODUCT: DIAGNOSTIC MOBILE WORKSTATION**

The KRSC332PC is a fully-enclosed Diagnostic Mobile Workstation, providing mobility and organization for a diagnostic unit and information system. Custom-cut foam organizers house the diagnostic system with all its accessories, including adapters and cables, for easy accessibility while being secured in a rugged, durable unit. The cart is equipped with a mounting plate inside the lid with pre-set weld nuts to attach a monitor permanently and securely for viewing from a distance when the lid is open. The cart is easy to open and shut — the monitor or diagnostic unit stays in position, ready-to-use. The inside of the top compartment accommodates a power strip (No. KAPS4) for easy power access in remote applications.

**CATEGORY: TOOL STORAGE**  
Enter 50 at "e-inquiry" on VehicleServicePros.com



**NOW, YOU CAN REPAIR TPMS SENSORS WITHOUT EVEN TAKING THE TIRES OFF THE VEHICLE.**

Most TPMS sensor failures are caused by galvanic corrosion of the valve core and stem. This sounds like an easy fix - but until now, service techs could not, in most cases, replace the valve stem without replacing the entire sensor module, rebalancing the wheel, and resetting the TPMS sensor. Proven reliable in thousands of miles of real-world, all-season testing, the Ken-Tool reCore Sensor Saver System changes all that.



Galvanic corrosion causes TPMS failures.



©2012 Ken-Tool. All Rights Reserved.

Visit us at ISN Booth #1118

**reCore™**  
TPMS Sensor Saver System

**SIMPLE.** The Ken-Tool reCore Kit (#29980) provides everything you need to repair the corroded valve core with a new, corrosion-proof valve core and stem. No need to have the TPMS computer re-learn the module. No need to even remove the tire or wheel from the vehicle!

**FAST.** With a little skill, your tech can install a new valve stem in 10-15 minutes.

**PROFITABLE.** The Ken-Tool reCore TPMS Sensor Saver Kit will not only pay for itself after a few uses — it will provide you with great profit margins.



For a FREE reCore System training DVD, email us at reCoreDVD@kentool.com.

**Ken-Tool®** 768 E. North St.  
**WHEREVER TIRES ARE CHANGED™** Akron, OH 44305  
Phone: 855-821-7309 • Email: sales@kentool.com



kentool.com/recore

Enter 51 at "e-inquiry" on VehicleServicePros.com

Visit us at ISN booth # 1118



**COMPANY: TRAXION**  
**PRODUCT: PROGEAR TOPSIDE CREEPER**

The ProGear TopSide Creeper has a fully-padded frame with a replaceable, padded upholstery cover. The cover is secured using Velcro, so it is removable for cleaning or replacement. The upholstered cover slides over a sling instead of a hard plywood deck. This improves comfort, reduces weight and makes replacing the decking much easier. The updated Professional Topside Creeper has an I-base design that allows more flexible positioning around the vehicle. The PRO TC allows the technician to reach 40 percent more area around the front of most vehicles and equipment.

**CATEGORY: JACKS & STANDS**  
 Enter 52 at "e-inquiry" on VehicleServicePros.com



**COMPANY: GLOBAL LEAK DETECTION**

**PRODUCT: SMOKE WIZARD POP-IT CAPLESS DOUBLE DOOR FUEL NECK ADAPTER**

The reusable Smoke Wizard Pop-it Capless Adapter (GLD052) fits the new, double-door, capless fuel necks. Simply pop it on, twist to seal and connect any leak detection device to test the system. This tool works well for EVAP tests, especially pressure/vacuum decay and smoke testing. It saves money and waste by never needing costly, messy, throw-away seals. The durable Pop-it Capless, made of fuel-resistant materials, is backed by a five-year warranty. Global Leak Detection, the Smoke Wizard manufacturer, is one of the oldest, most experienced OEM smoke machine manufacturers, serving Audi, Jaguar, Kia, Land Rover, Mazda, VW and other automakers, according to the company.

**CATEGORY: LEAK DETECTION**  
 Enter 53 at "e-inquiry" on VehicleServicePros.com

**Fast, convenient access to the reset procedures every shop needs**



Part # 13-450

**Maintenance Reminder Reset Procedures manual from Autodata:**

- Spiral bound format lays flat or folds in half for easy handling within the vehicle
- Vehicles are clearly indexed for fast access

**This manual includes:**

- Domestic and imported vehicles from 2002-2013
- Step-by-step instructions
- Vehicle-specific illustrations
- System operation notes



Order now:  
 Call 800-305-0338  
 or visit [www.us.autodata-group.com](http://www.us.autodata-group.com)

AD\_USA\_MRRP\_JUNE13\_PD

**COMPANY: LOCK TECHNOLOGY**  
**PRODUCT: LT991 HOLLOW END LINE TAPS**

Techs encounter the common problem of corrosion when removing high-pressure A/C, hydraulic and transmission lines. The lines and attached in-line female connectors are aluminum. Over time, the aluminum female fitting seizes to the dissimilar steel male fitting on the air compressor, power steering pump, transmission cooler, etc. When disengaging the female connector, the female internal threads are frequently damaged due to this corrosion. The line has to be removed and a new line ordered, creating costly and timely delays. The LT991 Hollow End Line Taps are center-drilled throughout the length of the tap. This creates clearance so the tap can chase and retread the female connector without having the flared end of the aluminum line preventing the tap from bottoming out inside the female connector. Normal solid taps are blocked from entering the female connector, requiring line removal.

**CATEGORY: AIR CONDITIONING**  
 Enter 54 at "e-inquiry" on VehicleServicePros.com

Enter 55 at "e-inquiry" on VehicleServicePros.com

ESSENTIAL TOOLS YOUR CUSTOMERS MUST HAVE!

# Reason #1

## Saves your customers fuel costs

### ESOC Series 450M

#### DIESEL ENGINE FUEL SYSTEM PRIMER AND FUEL RECONDITIONER

The Series 450M has been designed to facilitate the changing of all diesel fuel filters (cartridge, DAVCO and spin-on) while reconditioning the diesel fuel.



#### BENEFITS OF ESOC SERIES 450M:

- » Fast and clean.
- » On-board fuel storage tank
- » May be filled manually or using the engine's fuel pump.
- » Fully pneumatic.
- » Portable; can be used in the shop or on-site, using the shop or vehicle's air supply.
- » Very easy and convenient to use.
- » Safe for both operator and the environment.
- » Adjustable priming pressure feature.
- » Primes fuel system in seconds
- » Eliminates hand-priming
- » Eliminates water contamination utilizing water block filtering technology
- » Eliminates the need for a technician to handle the fuel.
- » Re-use reconditioned fuel from all fuel filters.



**Move at the speed of ESOC**  
Call your ESOC Commercial Truck Representative today at 866.909.3762 ext 229 or visit [www.esocinc.com](http://www.esocinc.com)

Enter 59 at "e-inquiry" on VehicleServicePros.com

## WINNERS



#### COMPANY: **BIG GATOR TOOLS** PRODUCT: **V-DRILL AND V-TAP GUIDES**

Big Gator Tools offers a unique line of patented Drill and Tap Guides. It is virtually impossible to hand drill or tap a perpendicular hole without a guide. When properly aligned using a guide, drill bits cut faster and taps cut uniform threads. Drill bit and tap failures are also reduced. These guides are manufactured using a heat-treated nickel alloyed steel. The guide base surface is machine ground to assure stability and perpendicular alignment on flat surfaces. The v-groove base allows the guide to be positioned on virtually any round object or square corners. Convenient alignment marks on one side of the drill guides center the guide holes over material to be drilled. Big Gator Tools currently offers two V-Drill Guides and four V-Tap Guides. All tools are 100-percent made in U.S.A.

**CATEGORY: TOOL ACCESSORIES**  
Enter 56 at "e-inquiry" on VehicleServicePros.com

#### COMPANY: **DREW TECHNOLOGIES** PRODUCT: **MONGOOSEPRO GM II**

Drew Technologies is now shipping the MongoosePro GM II. This Mongoose has been tested with GM's Tech2WIN diagnostics application. Tech2WIN is a Windows-based version of the Tech2 dealership scan tool that supports most 1996 to present GM vehicles. With Tech2WIN, a user can connect to powertrain, chassis and body systems to read trouble codes, view live streaming data, run bi-directional controls and perform diagnostic routines. GM offers Tech2WIN subscriptions at \$55 for a three-day license. This product is unique and innovative because MongoosePro GM II is the first aftermarket tool to support GM's Tech2WIN factory diagnostic software. It is also offered at a low price point, making factory diagnostics affordable to more technicians.

**CATEGORY: SCAN TOOLS**  
Enter 57 at "e-inquiry" on VehicleServicePros.com



#### COMPANY: **THEXTON MFG.** PRODUCT: **DEF CHEK TESTER**

The Thexton TH108 DEF-Chek Tester tests diesel exhaust fluid (DEF) to ensure that the urea concentration on the DEF is correct. Previous methods of checking urea concentration were very expensive, and the TH108 retails for under \$20. Diesel exhaust fluid is in all heavy duty vehicles 2010 and newer, which makes this tester increasingly valuable as the years go on. A failure to test diesel exhaust fluid may result in clogged injectors or fluid not working properly. The bulb design of this product has made testing quick and easy by simply placing the tester's hose into the DEF fluid and squeezing the bulb, obtaining a reading based on the amount of discs floating. If two discs float, the urea concentration is adequate. If any other amount of discs float, service manuals suggest replacing the DEF with new, known good DEF.

**CATEGORY: HEAVY DUTY**  
Enter 58 at "e-inquiry" on VehicleServicePros.com

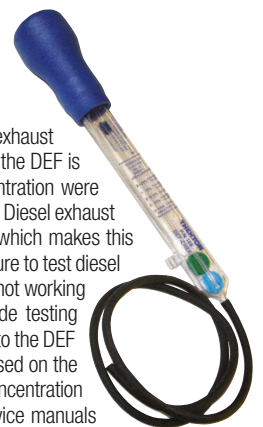

## WINNERS

### COMPANY: AUTODATA PUBLICATIONS

#### PRODUCT: QUICK-REFERENCE PRO

Quick-Reference PRO (QRP) is the online, quick-reference service information resource from Autodata Publications Inc. QRP covers over 4,200 vehicle models from 1995 to 2013. It provides auto repair shops with fast access to the most frequently needed automotive service information. Below is just a partial list of what is included:

- Maintenance schedules and illustrations.
- Technical service bulletins.
- Labor times.
- Diagnostic trouble codes, including definition and probable cause.
- Torque specs.
- Maintenance reminder reset procedures.
- Fluid capacities and types.
- Battery disconnect procedures.
- Key programming procedures.
- Timing belt/chain procedures.
- Wiring diagrams.



Autodata employs trained technicians with years of shop experience to compile, illustrate, link and present these critical pieces of OEM-sourced information within QRP. Information is easy to find and formatted to print efficiently. With QRP, technicians have the critical information they need at their fingertips, allowing them to spend more time in the service bay.

#### CATEGORY: REPAIR INFORMATION SOURCES

Enter 60 at "e-inquiry" on VehicleServicePros.com



### COMPANY: INNOVA

#### PRODUCT: DIGITAL COMPRESSION TESTER

The only handheld digital compression tester available on the market today, according to the company, Innova's handheld

Digital Compression Tester features a record/playback memory feature that means no more writing down recordings for each cylinder. The professional quality features of Innova's digital compression tester help pinpoint compression readings for quick and easy diagnostics. Additional key features and benefits include:

- Graphs and measures BAR, psi, kPa measurements of pressure.
- Real-time diagnostic testing for single/all cylinders.
- 0-300 psi, kg/cm2 and kPa operating range.
- Large digital display shows over 20 pieces of vital information at once.
- Automatic shut-off conserves battery.
- Intuitive hot keys and large LCD display.
- Displays results in progressive LED display: green means good compression, yellow means a potential problem, red means poor compression.

#### CATEGORY: SPECIALTY TOOLS

Enter 61 at "e-inquiry" on VehicleServicePros.com

## SUSPENSION AND DRIVELINE TOOLS



U-JOINT PULLERS



PITMAN ARM PULLERS



SLACK ADJUSTER PULLERS



AXLE SHAFT PULLERS



WHEEL STUD SERVICING



YOKE PULLERS



KING PIN PRESS



PIN & BUSHING PULLERS

**TIGER TOOL**  
International Incorporated

1 800 661 4661  
WWW.TIGERTOOL.COM



Enter 62 at "e-inquiry" on VehicleServicePros.com

# REPLACING EXPENSIVE A/C LINES WAS SO '2012'.

**15-MINUTE  
ON-VEHICLE  
A/C TUBE &  
HOSE REPAIR.**

You can now make fast and permanent A/C line and hose repairs **right on the vehicle** at a fraction of the time and cost of replacement. **That means more satisfied customers.**

## SWEDGE-LOK™



**2013 MACS  
Most Innovative  
New Product**



See the video!  
1-800-253-0403  
agscompany.com

Enter 67 at "e-inquiry" on VehicleServicePros.com

Visit us at ISN booth # 528



get precise readings. The tester verifies if a fuse is blown, if there is a parasitic drain or if there is no connection. This tool is not polarity-sensitive when contacting test leads to fuse contacts. Made in the U.S.A.

**CATEGORY: ELECTRICAL SYSTEMS**

Enter 63 at "e-inquiry" on VehicleServicePros.com

## WINNERS

**COMPANY:**

**MATCO TOOLS**

**PRODUCT: TH209 PROFESSIONAL  
CIRCUIT AND PARASITIC DRAIN TESTER**

The Matco Tools TH209 Professional Circuit/Parasitic Drain Tester tests circuits up to 80 amps using the fuse contacts instead of connecting the amp meter to the circuit. The unit tests mini, maxi and ATO fuses, and can be used on all domestic and foreign makes and models. The set includes the circuit/parasitic drain tester, two AA batteries and positive and negative test leads.

The Fuse Value button allows the user to select a specific fuse ranging from 5A to 80A to

**COMPANY:**

**INSPECTION CONNECTION**

**PRODUCT: PROSPEC**

Inspection Connection's ProSpec web-based software allows repair facilities to perform vehicle inspections with tablets, laptops and mobile devices. ProSpec offers several levels of inspections with a courtesy check, brake, fleet, vehicle profile, tire and customized inspections. All inspection products are designed to build sales of service and repairs with integrated photo capture, personalized coupons and "email-able" reports. With ease-of-use and built-in VIN decoding, any technician can perform inspections. ProSpec inspections are MAP compliant, offer ongoing technical support, can be shop branded, customized to repair facilities' specific needs and are designed with ease-of-use for any level of technician.

**CATEGORY: COMPUTERS & SOFTWARE**

Enter 65 at "e-inquiry" on VehicleServicePros.com



**COMPANY: ROTARY LIFT**

**PRODUCT: SPOTLINE LASER VEHICLE SPOTTING GUIDE**

Rotary Lift's patent-pending Spotline laser spotting guide improves technician efficiency and productivity by making it easy to properly position a vehicle on the lift the first time, every time. Spotline projects a green laser line directly into the middle of the vehicle service area. The technician simply centers the line on the vehicle hood and dash while pulling into the bay – there is no need to lean out the window or door. Originally introduced as part of Rotary Lift's Shockwave package for two-post and SmartLift inground lifts, Spotline is now available in a retrofit kit that's compatible with most lifts, regardless of brand. Spotline can be installed on the top of the lift or elsewhere above the work area. A motion sensor activates the laser when a vehicle approaches the bay to maximize battery life.



**CATEGORY: LIFTS**

Enter 66 at "e-inquiry" on VehicleServicePros.com

## WINNERS



**COMPANY: MIDTRONICS**  
**PRODUCT: GRX-5100 EV/HEV**  
**BATTERY SERVICE TOOL**

The GRX-5100 is the industry's first high-voltage hybrid/ EV vehicle battery service and de-power tool, according to the company. It was designed to safely perform full battery pack service, including de-powering, balancing and charging, via fully controlled and automated processes. Its simple menu prompts guide verification that the battery and communication systems are properly connected and that balancing or de-powering operations can begin.

The GRX-5100 features an electrical harness between vehicle batteries and communication systems via unique adapters for each vehicle model. It also utilizes USB-based memory, which will support system updates for future vehicle battery systems without a hardware upgrade. Midtronics developed the GRX-5100 to improve the serviceability of electric and hybrid vehicle battery systems, whether that be routine repair or complete de-power for safe transport, storage or recycling.

**CATEGORY: BATTERY STARTING/CHARGING**  
 Enter 64 at "e-inquiry" on VehicleServicePros.com



**COMPANY: LOCK TECHNOLOGY**  
**PRODUCT: LT1800 4-PC**  
**OFFSET IMPACT DRIVER SET**

Techs frequently experience great difficulty removing frozen studs and bolts during strut, break hub, front end, exhaust, spring and suspension repair. The compact nature of today's automotive mechanicals prevent easy access to many of these fasteners. The tools in the LT1800 4-Piece Offset Impact Driver Set are forged with a 15-degree angle at the drive head end. The angle can be increased up to another 30 degrees due to a machined recessed well at the head of the tool. Four machined, anti-turning slots at the base of the driver prevent the offset driver from turning during use in the impact chisel. Three sizes of well head — 0.410", 0.530" and 0.725" — reach the most inaccessible of fasteners, as well as a 0.990" straight shaft, non-turning air hammer. The hammer is much heavier than current ones on the market and also utilizes four non-turning slots machined at the base of the shaft. The hammer will not walk off the fastener during operation.

**CATEGORY: AIR TOOLS**  
 Enter 69 at "e-inquiry" on VehicleServicePros.com

**ERNST**  
 MANUFACTURING INC.

**PROUDLY MADE IN THE USA**  
**LIFETIME GUARANTEE**

**WE KNOW YOU**  
**NEED OPTIONS.**

Ernst has you covered.  
 Versatility is a must for organizing any socket set. Capitalize on unlimited configuration possibilities with the NEW **UNIVERSAL TWIST-LOCK SOCKET TRAY!**

**UNLIKE ANY OTHER.**

**VERSATILE**  
**TRANSPORTABLE**  
**SECURE**



Toll Free: (877) ERNST-TL  
[www.ernstmfg.com](http://www.ernstmfg.com)

Enter 68 at "e-inquiry" on VehicleServicePros.com

## Faster. Safer. Leak-free. Prevest Couplers.



**prevost**



With a simple push of a button, Prevest PS1 Couplers vent pressure then safely release the plug - eliminating the risk of personal injury or vehicle damage from hose-whip.

Prevest's leak free connections are also big energy savers.



**prevost**

**1-800-845-7220**  
[prevostusa.com](http://prevostusa.com)

Prevest Corp. | P.O. Box 17708 | 1200 Woodruff Rd. Unit A2 Greenville, SC 29606

Enter 70 at "e-inquiry" on VehicleServicePros.com

**Visit us at ISN booth # 1535**

## Diagnostic scan tools

Technicians often use scan tools as the first step in diagnosing issues with vehicles that come into their shops. Ever-changing technology makes tools in this product category important to stock on the truck. It is necessary to keep up on all the offerings available. Look through the next few pages to find new and updated products that may help your customers.



### Read, display and clear J1587 and J1939 faults

**DG Technologies' DG Diagnostics (DGD)** simplifies and lowers the total cost of service bay operations. DGD is a great "triage" tool and can read, display and clear J1587 and J1939 faults as well as display component information and parameters. There are also advanced features like data recording and playback, as well as GPS mapping. DGD can save shops thousands of dollars that may otherwise be spent on OEM-specific diagnostic software, according to the company. DG Diagnostics also reduces the need to "launch and learn" the dozens of full-featured OEM software products on the market today.

Enter 86 at "e-inquiry" on [VehicleServicePros.com](http://VehicleServicePros.com)

*The best scan tool depends on what vehicles you're working on.*



### Run multiple applications simultaneously

**Launch Tech USA's Launch Pad** offers the benefits of a tablet with the strength of the Launch diagnostic platform. With a Windows 7 operating system, multiple applications can be utilized simultaneously. The user can perform wireless-to-the-vehicle diagnostics, graph and record PID data, and use online repair databases all at the same time. Add-on modules allow for future adaptability, such as J2534 reprogramming and lab scope. Also

included is a free, 30-day trial of Identifix's Direct-Hit, which notifies the technician of vehicle-specific repair information and known fixes automatically, right on the screen. Enter 85 at "e-inquiry" on [VehicleServicePros.com](http://VehicleServicePros.com)

*There is no universal scan tool as of yet which would perform all needs on Euro, Asian and domestic vehicles.*



### Diagnose with Chrysler factory software

**Controller Technologies' DRB III Emulator** software application runs on a PC and interfaces via USB to the DRB III+ Pass-Thru hardware device enabling all the original functions a DRB III has for correct diagnosis and repair. The tool contains the exact DRB III scan tool software that dealerships use to diagnose and repair Chrysler, Dodge and Jeep vehicles from 1998 to 2007, and is now available to the aftermarket. With the addition of a J2534 Pass-Thru interface, this setup also serves as a flash programming and generic scan tool device, making this one of the most versatile tools in the market, according to the company.

Enter 73 at "e-inquiry" on [VehicleServicePros.com](http://VehicleServicePros.com)

### Provides diagnostic advice to techs

**Innova's FIX Assist Scan Tool** (No. 3130C) comes with numerous sophisticated features including FIX Assist, Innova's proprietary technology that gives users repair advice from actual ASE-certified technicians of the vehicle's problem on the tool in regards to its location and the verified fix information.

Additional features include:

- Plug-and-play diagnostics.
- Works on domestic, Asian and European vehicles 1996 and newer.
- ABS coverage for 1996 and newer GM, Ford, Chrysler, Toyota and Honda vehicles.
- Patented "System Status" allows user to see whether vehicle will pass emissions.
- View, record and play back live data.
- Patented hot keys allow user to view live/freeze frame data, erase codes and access ABS information.
- Compatible with Innova's RepairSolutions.

Enter 74 at "e-inquiry" on [VehicleServicePros.com](http://VehicleServicePros.com)





**Measure engine rpm with battery connection**

The **General Technologies TA303 Diesel and Gasoline Engine Tachometer** requires only a connection to the vehicle's battery or cigarette lighter socket to measure engine rpm. No sensors or reflective tapes are necessary, because the TA303 uses the ripples generated by the engine's alternator to automatically calculate its speed so it can be used on any diesel or gasoline engine equipped with an alternator. The TA303 is compatible with 12V to 42V DC electrical systems, and includes cables to connect to the vehicle's battery and cigarette lighter socket, a 10' extension cable, user's manual and a hard carrying/storage case.

Enter 75 at "e-inquiry" on [VehicleServicePros.com](http://VehicleServicePros.com)

*I don't like third-party financing; I'd rather take out a business loan and get the right scan tool, even if it's pricey.*

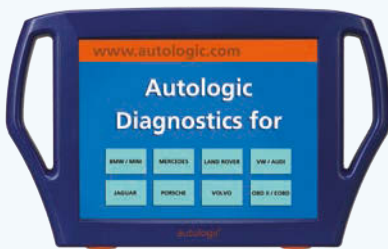

**Replicates OEM tools**

The **Autologic Diagnostic System** is designed to replicate the functionality (including coding and programming) of OEM tools used by automotive manufacturers. This system offers complete diagnostics for BMW, Mercedes-Benz, Land Rover, Jaguar, Volvo, Porsche and VW/Audi. Information is displayed on a large, touch-sensitive screen through a simple menu structure, supported by extensive help screens. Autologic software packages are available independently or as multiple packages run on the same Autologic hardware base unit.

Enter 76 at "e-inquiry" on [VehicleServicePros.com](http://VehicleServicePros.com)

*You do not look good to the customer if you do not have the capability of completing their repairs due to a lack of tooling.*

**NEW**  
TwinForce Diagonal



**EASY CUT, EASY SELL**

THE 7" TOOL THAT CUTS LIKE A 10"!



- MOBILE JOBBER SELLING TIPS**
- Twin offset rivets on both sides of the pliers head
  - Cuts 50% easier than other same length diagonal cutters (even at the tip!)
  - Handles open to the optimum width for one-handed operation

Part Number: 73 71 180

**KNIPEX – Tools Designed With Your Profits in Mind**

**Powerful Cutting.** That's what you get with the KNIPEX TwinForce High Leverage Diagonal Cutter and its patented dual rivet design.

To see a video on how to sell this one-of-a-kind tool, visit: <http://SellingTips3.notlong.com> or scan the QR Code with your mobile phone.



©2013 KNIPEX

KNIPEX Quality – Made in Germany

Visit us at ISN booth # 1540

Enter 77 at "e-inquiry" on [VehicleServicePros.com](http://VehicleServicePros.com)

## DRIVING SALES

### Updated diagnostic scanner

Autoland Scientech's iScan-II WT diagnostic scanner has dealer-level capabilities and coverage for more than 40 global vehicles. This next generation of the original Autoland iScan-II has a special functionality, including BMW offline programming that programs the models after E65, E60, E90, E70; an interface module simulation system (IMS2) interface with dealer scanner software, including Mercedes-Benz, BMW, Porsche, Volkswagen, Volvo, Toyota, Land Rover, Ford and Jaguar; and DOL (diagnostic online) accessible through the Internet. Technicians always get the latest information via built-in Bluetooth technology and report information for programming and reflashing.

Enter 78 at "e-inquiry" on [VehicleServicePros.com](http://VehicleServicePros.com)



### Scan with OEM enhanced functions

Autel's MaxiDiag Elite, No. MD802, derived from the MaxiDAS DS708, enables the user to not only get into the enhanced OBDII system with Mode 06 access, live data and graphing, but it also allows a technician to scan the entire car, all makes, all models and all modules, according to the manufacturer. The tool can read and clear codes in all powertrain, chassis, body, and information and communication systems with the push of one button. With its print function, the user can provide the customer or the insurance agent a complete diagnosis of the vehicle.

Enter 79 at "e-inquiry" on [VehicleServicePros.com](http://VehicleServicePros.com)



Stop by Booth # 1032 to see what's new at the 2013 ISN Tool Dealer Expo!

The Pros Know

EXCEPTIONAL  
RELIABLE  
TOUGH

The essence of an  
American legacy



AUTOMOTIVE



HARDWARE/CONSTRUCTION



INDUSTRIAL/MRO

**MAYHEW**

Since 1858

The Pros Know

[www.mayhew.com](http://www.mayhew.com) | 1-800-872-0037

*The price of the scan tool is one thing, but updates can sometimes make a tool hard to afford.*



### RP1210 and J2534 programmer

Drew Technologies' TVIT offers flexibility and rugged performance, and its advanced software provides for improved diagnostic and flash repairs for today's heavy duty vehicles. TVIT provides vehicle coverage for today's most popular diagnostic and reprogramming services from Allison, Cummins, Freightliner, Mack Trucks and more. Supporting RP1210 systems, TVIT is equipped to also provide coverage for manufacturers using SAE J2534 standards found in both heavy and medium duty vehicles.

Enter 80 at "e-inquiry" on [VehicleServicePros.com](http://VehicleServicePros.com)

Enter 81 at "e-inquiry" on [VehicleServicePros.com](http://VehicleServicePros.com)

Visit us at ISN booth # 1032



## Speaking scan tool

**Injectronic's CJTalk** is the first talking OBDII scan tool. It vocally informs the user of codes and can capture DTCs as a bitmap graphic file, viewable live via USB connection on a PC. The unit works across ISOs, CAN, J1850PWM and VPW protocols with future software updates available over the Internet. The unit does not have a display or keypad so that it can be used strictly as a plug-and-play unit, and uses color-coded LEDs to provide simple, clear readiness and cycle verification. Data in the scan tool is stored on an internal flash memory card. The unit also can clear DTCs at the flip of a switch.

Enter 84 at "e-inquiry" on [VehicleServicePros.com](http://VehicleServicePros.com)

*All universal scan tools have a limited capability and you'll end up calling someone for European vehicles if it needs programming, immobilizer and etc.*



## Ford, Lincoln and Mercury dealer level diagnostics

The **Hickok/Waekon NGS PC**, No. 90068, brings the dealer level diagnostics of the NGS to a personal computer, laptop or mobile PC platform. User-friendly menus provide quick access to on-board diagnostic functions for fast and efficient diagnosis. Save parameter recordings to create a database of vehicle histories and/or a reference library of known good values. Features include:

- Power balance misfire diagnostics.
- Automated EVAP monitor test.
- Access all module protocols including UBP.
- Access all modules including body control modules.
- Diesel diagnostic coverage: 7.3L, 6.0L, 6.4L and 6.7L.
- PATS key reprogramming.
- Active commands driver seat diagnostics.
- ABS service bleed functionality.
- Click and go diagnostics.
- 1996 through current model year.
- 30-day trial offer available.
- Made in U.S.A.

Enter 83 at "e-inquiry" on [VehicleServicePros.com](http://VehicleServicePros.com)

## REALLY RESET:

- Oil Service Reminder Light
- Service & Maintenance Reminder Lights when replacing:
  - Microfilters
  - Front Brake Pads
  - Rear Brake Pads
  - Spark Plugs
  - Brake Fluid
  - Coolant
  - Diesel Filter
  - And More!
- Vehicle Inspection Light
- Exhaust Emission Light

MSRP: \$149.95

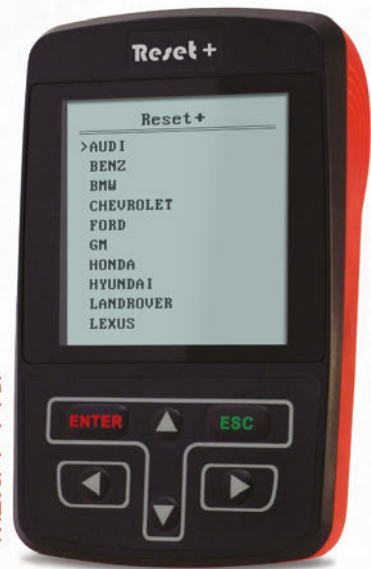

### BMW 545i

>Vehicle Inspection  
 Engine Oil  
 Front Brake  
 Rear Brake  
 Brake Fluid  
 Dust Filter  
 Spark Plug

Optional Resets For European Applications

### 2006-2010

1. Turn on the ignition.
2. Pull the button to the right of the Service Reminder to display the 'SERVICE' message.
3. Pull the button

Manual Resets For Cars That Require It

**CanDo**  
 INTERNATIONAL, INC.

p: 1-909-CanDo-11(226-3611)  
[www.candointl.com](http://www.candointl.com)

Scan the code to see the **Reset+** perform a Service Reminder Reset on an Audi!



Enter 82 at "e-inquiry" on [VehicleServicePros.com](http://VehicleServicePros.com)

Visit us at ISN booth # 432

## DRIVING SALES

*“The benefit of really high-end aftermarket scan tools is that their software engineers can make custom reflashes that the OEM doesn't provide.”*



### Reset BMW service lights

**Strategic Tools & Equipment's BMW Service Tool, No. ABMWSLR12**, acts as an OEM-level service reset tool for late-model BMW vehicles with “condition-based service” functions. View current conditions and reset each item once service has been performed or items have been replaced. This tool is updatable via the Internet. Reset service indicators for engine oil, brake fluid, front and rear brake pads, spark plugs, interior air, microfilter and diesel particulate filters; and vehicle check and vehicle inspection counters. This tool allows technicians to reset service lights for all BMW vehicles from model years 2002 to 2009, according to the company. Enter 71 at “e-inquiry” on [VehicleServicePros.com](http://VehicleServicePros.com)



### Diagnose more vehicles

**AutoEnginuity's ProLine VCI and ScanTool 11.1**, for Windows PCs, supports new electrical improvements such as the improved protection for ISO pins to prevent errant vehicle power from overheating the connector. Electronics required for the new Fiat, Ferrari and Maserati enhancements also come with it. Finally, more electrical switches were added to allow for more K line isolation from other protocols, making switching protocols more reliable on mixed bus vehicles. The ProLine VCI update includes an integrated security dongle freeing up a USB port for other devices and making the connection easier to perform with one less device to connect. Enter 72 at “e-inquiry” on [VehicleServicePros.com](http://VehicleServicePros.com)

## Rotabroach® Master Kits

### Cut More Holes, in More Sizes...

... with tools that last **10x** Longer & cut **3x** Faster than twist drills or hole saws.

New kits include **16 sizes** of Rotabroach Cutters, arbor, extra pilots & center punch.

Available in fractional and metric sizes.

From fabrication to restoration, nothing compares to the quality and speed of a Rotabroach Cutter.

Don't be left searching for the one size you don't have, complete your tool box with a Master Kit from Blair.



**“Holemaking & Auto Body Solutions for the Professional!”™**



**Blair Equipment Co.**  
www.blair-equipment.com  
800-426-7818

Enter 90 at “e-inquiry” on [VehicleServicePros.com](http://VehicleServicePros.com)

42 / Professional Distributor / June 2013 / [www.VehicleServicePros.com](http://www.VehicleServicePros.com)

## BIG JOBS

**3/4" EXTENDABLE RATCHET DRIVER**  
MR34

**SMALL JOBS**

**QUARTER STICK 1/4" RATCHET DRIVER** 4S12

### Tools for any size job.

From 3/4 inch Ratchets that extend to 40 inches, to 1/4 inch bit drives with flex heads, we make the tools that are needed in today's world. Call your distributor today and check out our innovative line of tools.



Enter 91 at “e-inquiry” on [VehicleServicePros.com](http://VehicleServicePros.com)

Visit us at ISN booth # 1537

## DRIVING SALES



### Multi-system diagnostics tool

The Cojali USA, Inc. Jaltest Multibrand and Multisystem Diagnostics Tool features bi-directional controls, so the user will have access to more than just reading codes, such as cylinder cutouts, cylinder balance, compression tests and solenoid valve actuations. The Jaltest info feature provides the most complete technical information database available on the market today, according to the company. The feature helps techs locate a component through wiring diagrams, as well as troubleshooting the problem through available systematic guides. Jaltest offers a fixed software update forecast. With each software license, the user gets high-end diagnostic solutions in three updates per year: access to new software updates, available system technical information, new functions and additional coverage. Cojali supports this diagnostic tool with a product support team, in-depth training programs and customer service to help businesses grow in their markets. **Enter 87 at "e-inquiry" on VehicleServicePros.com**



### Scanner and J2534 reflasher

Delphi's Auto IQ Service Solutions Program features the **Delphi Diagnostics Scan Tool** that can perform OEM-enhanced functions and operate as a J2534 reflasher. This tool includes OE-based service repair information, ASE-certified support, training, mobile e-catalog and connected car telematics solution, and comes as a wifi-ready, touch-screen tablet. This scan tool includes a variety of parameters, tests, device controls and thousands of bi-directional device controls. Coverage starts with 1995/1996 model year vehicles and includes complete coverage for all domestic and leading Asian manufacturers. European applications will be available in early 2013.

**Enter 92 at "e-inquiry" on VehicleServicePros.com**



## SP AIR CORPORATION

1/4" & 3/8" SUPER FAST MINI IMPACT RATCHET

SP-1764 (1/4")

SP-1765 (3/8")



High Speed



High Torque



Reaction Free

For a SP-1765 Demo Video visit: [youtube.com/spairtools](http://youtube.com/spairtools) or Scan the QR Code

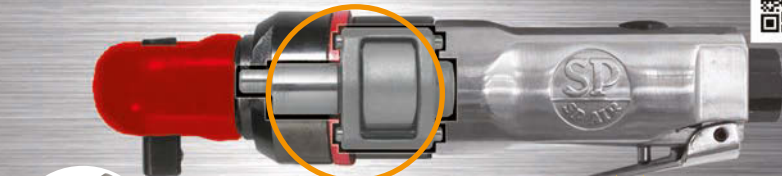

Single Dog Clutch

IMPACT MECHANISM PATENTED

500rpm/55ft-lbs.

MADE IN JAPAN

### Model: SP-1764(1/4") / SP-1765(3/8") SPECIFICATION

Sq. Drive	Bolt Capacity	Maximum Torque Range	Free Speed
3/8" (9.5 mm)	3/8" (10 mm)	55 ft-lbs. (74 Nm)	500 rpm
1/4" (6.35 mm)	5/16" (8 mm)	50 ft-lbs. (68 Nm)	
Overall Length	Net Weight	Vibration Level	Sound Level
6-7/8" (175 mm)	1.4 lbs. (0.63 kg)	2.9 m/s <sup>2</sup> 2.4 m/s <sup>2</sup>	84.4 dB 83.6 dB

SP Tools, Inc. Toll Free 855-438-5313 sales@sptoolsinc.com  
Phone: 614-529-6600 <http://www.sptoolsinc.com/>

Enter 88 at "e-inquiry" on VehicleServicePros.com

Introducing the

## TRACERLINE®

### Hybrid Vehicle A/C Dye Injection Kit

Locating leaks in hybrid A/C systems requires special service considerations. That's why we developed the **TP-3812 Hybrid Vehicle A/C Dye Injection Kit!** With its specially formulated fluorescent dye and super-convenient injection method, it's the fastest and safest way of pinpointing refrigerant leaks in any hybrid vehicle!

#### Features:

- Tracer-Stick® co-solvent free, POE dye capsules with a unique additive package specially formulated for hybrid A/C systems!
- R-134a low-side connect set allows fluorescent dye and refrigerant to be added into the system simultaneously, in one simple step!
- Works with both UV and blue light inspection lamps!

**TRACER PRODUCTS**  
A Division of Spectronics Corporation  
Westbury, New York USA

ISO 9001:2008 CERTIFIED COMPANY



## You Can Find Hybrid A/C Leaks!

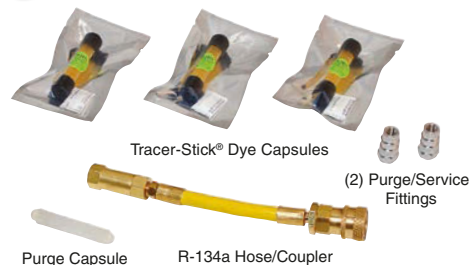

The TP-3812 Hybrid Vehicle A/C Dye Injection Kit comes complete with three Tracer-Stick® dye capsules individually wrapped in a moisture-resistant foil pouch with a desiccant bag, R-134a hose/coupler, two purge/service fittings and one purge capsule.

To learn more, call **516-333-1254** or visit [www.tracerline.com](http://www.tracerline.com)

**We Take Leaks Seriously!**

Enter 89 at "e-inquiry" on VehicleServicePros.com

# Ingersoll Rand 3/8" and 1/2" Cordless Ratchet Wrenches

These cordless ratchets are ideal for brake and engine repairs and undercar work.

**T**he Ingersoll Rand R3130 3/8" and R3150 1/2" cordless ratchets are the latest tools in the IQ V20 Series. This tool's 20V lithium-ion battery is compatible with the other cordless tools in the series so distributors can sell the entire product suite. The convenience of a cordless tool gives technicians the ability to do repairs outside the shop without having to drag out an air hose.

## Selling points

- The R3130 and R3150 are in a class of their own, with true 3/8"-class performance — very different from the many 1/4"-class lower voltage cordless ratchets now on the market.
- Distributors can count on the fact that the R3130 and R3150 are manufactured with the same durable heads as Ingersoll Rand air-powered ratchets, which are proven to stand up to tough bolts.
- A technician will typically hook up two to five different tools during the course of a job. Using this cordless ratchet allows the technician to spend less time connecting and disconnecting tools from the air line so he or she can complete the job more efficiently with less time wasted.
- The R3130 and R3150 feature a slim profile and inline battery orientation to allow access to anywhere a full-powered air ratchet can reach, without giving up any of the performance.

## Features and benefits

The compact 20V lithium-ion battery

*This tool's 20V lithium-ion battery is compatible with other cordless tools in the Ingersoll Rand IQ V20 Series.*



gives technicians freedom from air lines and the versatility to use this tool anywhere inside or outside the shop, saving them time from having to constantly change tools on the shop air lines. The battery is compatible with the other IQ V20 Series cordless tools so technicians always have a fresh battery when they need it and can complete projects faster.

With the unique slim-line design, the battery pack sits behind the palm of a technician's hand and the ratchet can fit into the same spots as his or her arm, providing easy access to tight spots. The cordless ratchet also delivers 54 ft/lbs of torque to quickly complete automotive and industrial equipment repairs. In addition, the patent-pending metal and composite housing and all-metal gear train help the tool survive repeated drops on garage floors.



## Application

These ratchets are ideal for brake and engine repairs and undercar work, as well as a wide range of industrial maintenance applications.

## Origin

The R3130 was manufactured to replace the Ingersoll Rand R380 ratchet wrench. The R380 had a parallel battery pack that limited its reach. The R3130 has an in-line battery design that enables the tool to fit into spaces the size of the user's arm. The innovative battery design was the biggest improvement made to the new ratchet. The power-driven ratchet is one of the most used tools in a technician's toolbox. The R3130 and R3150 were developed to enable productivity by offering cordless "freedom" from the air hose.

The two problems to solve were to deliver a cordless alternative that did not sacrifice performance and to overcome the "perception of bigness" of the battery. By utilizing a high-power motor and the company's 107XPA ratchet head along with innovative battery orientation, the company was able to overcome both problems.

## Manufacturing specs

All the IQV20 Series cordless tools are designed in Annandale, N.J., and made



*With these ratchets, techs can access tight areas such as engine compartments.*

in the Ingersoll Rand manufacturing facility located in Changzhou, China. The R3130 ratchet, used in conjunction with the 1.5 or 3.0 Ah battery pack, weighs 4.4 lbs and offers 54 ft/lbs of torque. The patent-pending metal and composite housing makes the tool lightweight for easy operation, yet durable enough to withstand repeated drops.

### Storage and display

The R3130 and R3150 are available as bare tools and in kits with one or two 1.5 Ah lithium-ion batteries. Kits are assembled in a durable, blow-molded case with spring hinges, which allow the top to be removed for display or storage in the drawer of a toolbox.

### Suggested retail price

- R3130 3/8" 20V ratchet: \$362
- R3130-K1 kit w/ R3130, charger, (1) BL2005 battery and case: \$499
- R3130-K2 kit w/ R3130, charger, (2) BL2005 batteries and case: \$629
- R3150 1/2" 20V ratchet: \$371
- R3150-K1 kit w/ R3150, charger, (1) BL2005 battery and case: \$506
- R3150-K2 kit w/ R3150, charger, (2) BL2005 batteries and case: \$646

### For more information

Keely Pearson  
Two Rivers Marketing  
KeelyP@2rm.com  
(515) 557-2025 ■

**Enter 93 at "e-inquiry" on VehicleServicePros.com**

## SUMMIT BODYWORKS

**YOUR PREMIER TOOL TRUCK BUILDER**

Mention this ad and get a **FREE** beverage cooler installed in your new truck. Call for details

### Quality. Value. Summit.

6691 Colorado Blvd. Commerce City, CO 80022  
888-375-3446 • www.summitbodyworks.com

**Enter 94 at "e-inquiry" on VehicleServicePros.com**

Visit us at ISN booth # 412

## THEXTON SPRING TROUBLE TAMERS

Part No. 108

### DEF-CHEK DIESEL EXHAUST FLUID TESTER

Tests urea concentration in Diesel Exhaust Fluid. Floating discs show whether DEF concentration is too rich, too diluted or the proper 32.5% mix.

Part No. 495

### TERMINAL RELEASE TOOL KIT

Aids in removing faulty terminals without damaging connectors. Tools have special tips to depress locking tab in various connectors.

See our How-To Tool Videos at [thextontoolsYouTube.com](http://thextontoolsYouTube.com)

## THEXTON

6539 Cecilia Circle Edina, MN 55439  
800-328-6277 www.thexton.com

**Enter 95 at "e-inquiry" on VehicleServicePros.com**

Visit us at ISN booth # 627

# Hein Werner Engine Stand

Engine stand head locks into any position along its 360-degree rotation.

**T**he American-made, Hein-Werner 1,250-lb Engine Stand, No. HW93778, combines strength and ease of operation. The head will lock into any position along its 360-degree rotation. The head is rotated by a long handle in the back of the stand, making the rotation of the engine an easy task. It stands on a strong, sturdy frame built from heavy-gauge, welded, square-tubular steel atop an H-frame with two fixed wheels at the front of the stand and two rear-swivel casters for maneuverability.

## Selling points

- Made in the U.S.A.
- 360-degree head plate rotation.
- Four adjustable mounting arms.



*Users can lock the engine stand head into any position along the 360-degree rotation.*

- Heavy-gauge, steel-tubular frame.
- Four wheels and two swivel casters on 36" and 35" 'H' base frame.

## Features and benefits

The Hein-Werner engine stand allows users the ability to independently hold an engine block for an extended period of time and to rotate it to the user's preference, saving valuable time and energy when working.

## Application

This piece of equipment assists with engine assembly, disassembly and other thorough maintenance.

## Manufacturing specs

- Made in the U.S.A.
- 1,250-lb capacity.
- Constructed of heavy-gauge, welded, square-tubular steel.
- Weighs 79 lbs, gross weight.
- 36" x 35" 'H' base frame.

## Storage and display

- 37-3/4" by 39-3/4" by 10" box dimensions.
- Individually packaged.

## Suggested retail price

\$599.99

## For more information

10939 N Pomona Ave.  
 Kansas City, MO 64153  
 (816) 891-6390  
 HeinWerner-Automotive.com ■

Enter 96 at "e-inquiry" on VehicleServicePros.com

**We've got your back!**  
**TMX-589 TECH METER KIT**

**Includes:** **New Item!!**

- True RMS DMM - CATIII 1000V - IP67 Waterproof
- LOADpro® Test Leads
- Troubleshooting Book
- DVD Training Video 1 Hr.
- Compass for alternator & solenoid testing

"This kit will build your confidence."  
 Bryan Lewis  
 ASE Master Tech  
 2 Time SuperTech  
 Champion

We've got your back with one hour of video instructions, diagnostic tips & applications. DVD included with TECH METER KIT. We know you want more information...you asked, we did it. **ES**

Call 800-227-1603 for more info. - [www.esitest.com](http://www.esitest.com)

**TMX Tech Meter**

Enter 97 at "e-inquiry" on VehicleServicePros.com Visit us at ISN booth # 208

# SP Tools/Schley Products Ford 6.7L Diesel Injector Socket Set

This tool gives technicians the ability to remove various injector lines.

**T**he SP Tools 11400 Ford Power Stroke 6.7L Diesel Injector Socket Set comes as a 17mm, 12-point flare nut socket that gives techs the ability to remove various injector lines. With the geometry of this tool, injectors can be removed without breaking and damaging the electrical connections. The crows foot can be spun by hand under the bent lines and the long socket has the clearance required and linear shape to properly torque the fuel lines. This allows the user to torque the fittings without complex mathematical equations when using torque adapters.

## Selling points

- All Ford diesel technicians need these sockets to properly service the high-pressure injectors.
- This is a factory-quality tool that all Ford diesel technicians would be interested in purchasing.

## Features and benefits

- The sockets are designed to not damage the delicate plastic plug connector on the injector, which can have a replacement cost of over \$500 each.
- Sockets allow easy access to the hard-to-reach injector location, making injector removal much quicker.
- Two different socket designs: one is longer and allows for accurate re-torquing of injector fuel line; the second one is shorter and can be spun by hand under the fuel line for quick removal of the fuel line nut.

## Application

- Any kind of fuel system repair on Ford's 6.7L diesel in the company's super duty trucks.
- Special design ensures no damage to the injector during service.

## Origin

Technicians came to SP Tools because they had issues accessing the injector fuel line with conventional wrenches. In some cases, when they were able to access the injector with conventional tools, the plastic plug connector was damaged, costing the technician out-of-pocket for replacement.

## Specs

- This tool is made from heat-treated, 4140 chromoly steel and features the company's high-tech black finish.
- SP Tools has torque-tested these sockets to over 200 ft/lbs without failure.
- The socket set ships in a custom-made, clear clam shell with an informative insert card.

- SP Tools suggests hanging the set from a peg board.

## Suggested retail price

\$69.95

## For more information

www.SPTool.com  
(714) 693-7666 ■

Enter 98 at "e-inquiry" on VehicleServicePros.com

*This tool helps remove injectors without damaging electrical connections.*



**Attn: PDR** Now you can quickly pull glue tabs with the **STECK StudLever™**

- **FAST!!!!**
- **ACCURATE**
- **EASY!!**

Part #20013



**Tab-It™**  
Glue Tab Kit for Steck StudLever



**Tab-It with StudLever shown pulling glue tab**

ANOTHER GREAT TOOL BY...

See your local tool distributor

or visit [www.steckmfg.com](http://www.steckmfg.com)



Enter 99 at "e-inquiry" on VehicleServicePros.com **Visit us at ISN booth # 1234**

# SNEAK PEEK

**W**elcome to Sneak Peek! This product section features exclusive, recently introduced automotive tool and equipment products. In Sneak Peek, we'll show you new tools even before automotive technicians get to read about them in *Professional Tool & Equipment News* magazine. Sneak Peek products will help you stock your truck with the latest and greatest tools on the market.



## BALANCE WHEELS MORE QUICKLY

**Ranger Products' DST64T wheel balancer** comes equipped with revolutionary DataWand and an inner data set arm allowing operators to quickly and automatically enter wheel parameter settings in less than three seconds for exact balancing every time. A soft-touch key pad and display panel provides dynamic, static and variable alloy settings and features dynamic tire and wheel graphics to help guide technicians through balancing procedures. The weight optimization feature automatically calculates the minimum amount of weight needed to achieve an optimal balance so shops use less weight and increase profits.

Enter 100 at "e-inquiry" on [VehicleServicePros.com](http://VehicleServicePros.com)

## SERVICE BMW FUEL INJECTORS

**SP Tools' BMW Injector Puller, No. 11800**, allows for easy removal of injectors on all BMWs with direct injection. On in-line, 6-cylinder engines, the tool allows the user to simply screw the tool on to the top of the injector, and after tapping the slider, the injector comes out easily. It also helps ease the removal of injectors on V8s as well. The tool benefits the user by being quicker than using the factory tool, according to the manufacturer.

Enter 101 at "e-inquiry" on [VehicleServicePros.com](http://VehicleServicePros.com)



## Every Toolbox Needs...

### WALTON™ Tap Extractors & Tap Extensions



Available as sets or individual pieces



• Professionals in a wide variety of industries have depended on high-quality Walton tools since 1908.

• **Tap Extractors** will remove broken taps simply and safely, without drilling, lasers, damaged threads, scrapped parts or repair inserts. Available in every tap size, both inch and metric.

• **Tap Extensions** will extend the reach of regular-length taps and allow tapping in deep holes and awkward locations. Square and round sockets conform to leading tap sizes, and these tools are suitable for both machine- and hand-tapping.

Tapping into good ideas for over 100 years

MADE IN THE U. S. A. SINCE 1908



600 New Park Avenue, West Hartford, CT 06110  
Tel: (860) 523-5231 • Fax: (860) 236-9968

email: [sales@waltontools.com](mailto:sales@waltontools.com) • [www.waltontools.com](http://www.waltontools.com)

Enter 104 at "e-inquiry" on [VehicleServicePros.com](http://VehicleServicePros.com)

## TOOLS Koken®

Specializing in the worlds highest quality Sockets, Ratchets, and Automotive aftermarket tools for over 65 years.

OVER 8,000 STANDARD ITEMS!



[www.kokenusa.com](http://www.kokenusa.com)  
(978) 455-0672

10 Kidder Road Unit 4 Chelmsford, MA 01824

Enter 111 at "e-inquiry" on [VehicleServicePros.com](http://VehicleServicePros.com)



**REMOVE HARLEY FILTERS WITH NO MESS**

Ernst introduces the **Greg's Drip-Free Oil Filter Funnel** for use on all Harley Davidson Evo and Twin Cam motorcycles 1985 to present, with a forward-mounted oil filter. This funnel keeps oil from damaging the Harley's rubber engine mount. The tool's U-shaped design fits the filter like no other funnel can and fits in tight places when refilling oil, transmission and primary fluids. The tool boasts American-construction with a lifetime guarantee.

Enter 105 at "e-inquiry" on VehicleServicePros.com



**KEEP AIR RATCHET ACCESSORIES ORGANIZED**

King Tony America's **Mighty-Seven 57 Piece Hybrid 3/8" Drive Air Ratchet Set**, No. NE-0357, comes as an almost five dozen air ratchet set that acts as a 3/8" drive and a 1/4" drive ratchet. The set also includes a built-in, bit holder head for 1/4" bits. The set totals 57 pieces - one air ratchet, seven 1/4" drive sockets, six 3/8" drive sockets, 40 1/4" bits, one 3/8" extension bar, one 1/4" hex size shank driver and one 1/4" NPT air adapter. This entire set is encased in a portable and rugged hard plastic case.

Enter 106 at "e-inquiry" on VehicleServicePros.com

**TEST ANTIFREEZE**

Clore Automotive's **Automotive Refractometer**, No. 5026, from Viper features a variety of enhancements to make antifreeze/coolant assessment faster and easier, including an adjustable viewfinder with separate scales per fluid, easy-to-read graphics and a high-contrast lens for clear, accurate viewing. It features separate scales for ethylene glycol, propylene glycol and battery acid specific gravity. The tool also features automatic temperature compensation, which enables a quick, accurate reading regardless of ambient temperature. The automotive refractometer remains the only OEM-approved method for testing the freeze point of antifreeze and coolant, according to the company.

Enter 103 at "e-inquiry" on VehicleServicePros.com

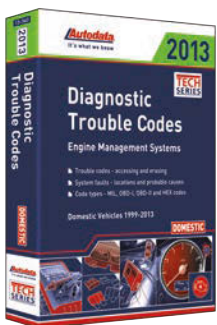

**LOOK UP DTCS**

The **Autodata 2013 Domestic Diagnostic Trouble Codes Manual**, No. 13-340, provides concise text and clear illustrations for domestic vehicles, for code retrieval techniques in separate sections for each model. It includes trouble code, fault locations and probable causes researched from OEM diagnostic flowcharts for vehicles from 1999 to 2013. The book also covers how to delete DTCs on different modules and DLC locations.

Enter 102 at "e-inquiry" on VehicleServicePros.com

**CLASSIFIED ADVERTISING**

**Use All the Tools of the Trade!**

Professional Distributor offers a wide variety of classified opportunities just waiting for you!

Contact Michael Braun for more information:  
Toll Free: 1-800-547-7377, ext. 1396  
E-Mail: Michael.Braun@cygnus.com

**K&E TOOL**

- Assembly
- Industrial
- Heavy Duty
- Automotive

**Come check out what's new with K&E at ISN Tool Dealer Expo!**

Booth 304

New for 2013, K&E will be introducing new air tool products and our new K&E Gear Professional LED flashlights, spotlights & headlights!

KE-275EXT KE-FL89 KE-WL500 KE-7302 KE-1650EXT KE-2175/2176

**www.ketools.com • 1-800-235-1782**

# NOTHING PREPARED US For The Boston Marathon Bombing



### BY GLEN FOSBERG

Glen Fosberg is a Mac Tools distributor based in Ashland, Mass. who covers the greater Boston area. He has been a mobile distributor for Mac Tools for more than 30 years.

**A**pril 15th is a day those of us in Boston will remember. I was finishing my last stop of the day when I got a text message from my daughter about the bombings at the Boston Marathon. I had started the day early as I always do on that day because if I don't, the roads will be closed. I live in Ashland, Mass., which is 20 miles west of Boston, and a lot of the roads that I normally take to my stops get closed for the marathon.

When my daughter texted me, I clicked on the news on my mobile phone and learned about the tragic bombing. It was my last stop of the day, so I just headed home.

When I got home, I put on the TV and watched the news. People were killed and injured. I felt sad for the victims and hoped that my own friends and acquaintances were not among them.

*Boston, Massachusetts, USA - April 28, 2013: People gather around the second bomb site one week after the Boston Marathon bombing. They are gathered to lend support and place flowers and trinkets on the location where three people died.*



On Tuesday, I went to work and soon learned that two of my customers had run in the race. Fortunately, both had finished the race before the bombing occurred and they escaped injury.

For the next couple of days, police were everywhere. I drove my truck to my usual stops throughout greater Boston. The bombings were all people were talking about. No one had ever had anything like this happen before.

### Customer knew the suspect

When the images of the suspects were flashed across the TV screens, one of my customers told me he recognized one of the two men. And when the suspects' identities were announced, my customer said he was correct that the face he recognized was in fact a guy he knew in high school. He was pretty shocked because he had no idea this guy would be involved in something like this.

The bombings and the whereabouts of the suspects were on everybody's mind Tuesday, Wednesday and Thursday.

A lot of people wondered how this horrible event could have been prevented. But in such an open space as where the bombing occurred, I don't know what you can do to prevent it.

Friday was the day that the surviving suspect was caught. I got in my truck as usual that morning and headed to Newton, a western suburb of Boston.

In retrospect, I realize that I was lucky that it wasn't the day that I normally go to Watertown, where the surviving suspect was caught. I normally go to Watertown on Monday.

I noticed the streets were deserted. There weren't any buses or taxis on the streets. I knew something was going on, but I didn't know what. I had heard nothing on the news when I left my house in the morning.

When I got to my first stop, I noticed there was no one inside. Then someone opened the door and told me there was a police lockdown in effect for the day and that I should go home. I went to a couple more stops and realized that no one was open for business, so I went home.

I kept the TV on at home and watched the drama unfold. On Thursday, the suspects had killed a security guard at the Massachusetts Institute of Technology in Cambridge and hijacked a car. On Friday, the police killed one of the suspects and captured the other one in Watertown.

Fortunately for me, Friday is my least busy day. I schedule it that way. So losing the sales on Friday did not affect me as much as it would have on another day.

In my 30 years working as a Mac Tools distributor, I have never witnessed an event like this.

On the following Monday, everything was back to normal. There were still a lot of police cars on the streets, but businesses were open and people were back to their regular routines.

By the media coverage of the bombings, it's obvious the whole country shares in our loss. But for those of us in Boston, the loss is more personal. ■

Have an interesting experience to share with your fellow mobile distributors? Contact Editor Elliot Maras by phone at 800-547-7377 ext. 1963 or by email at [elliott.maras@cygnus.com](mailto:elliott.maras@cygnus.com).



# TOOL FAIR

# 2013

# THANK YOU!

On behalf of Neu Tool we can't thank you enough! The weekend was filled with excitement.

Nothing was more rewarding than welcoming all the distributors. We hope you enjoyed your time.



Check out all the Tool Fair photos on our Facebook page



**Neu Tool & Supply Corp.**  
Premier Warehouse Distributor

P: 855-NEU-TOOL F: 262-432-1281  
[www.neutool.com](http://www.neutool.com) [www.toolmarket.com](http://www.toolmarket.com) [sales@neutool.com](mailto:sales@neutool.com)



Enter 109 at "e-inquiry" on [VehicleServicePros.com](http://VehicleServicePros.com)

# FUTURE SUCCESS STARTS TODAY



## DF-505/220v

THE ULTIMATE DENT PULLING STATION

Handles light to heavy pulls

Can do pins, wiggle wire, pull rods and shrink

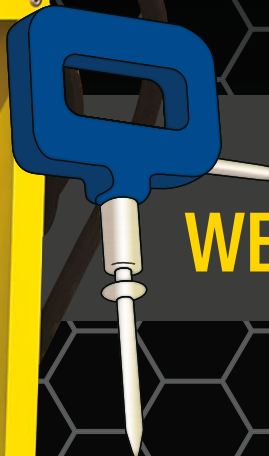
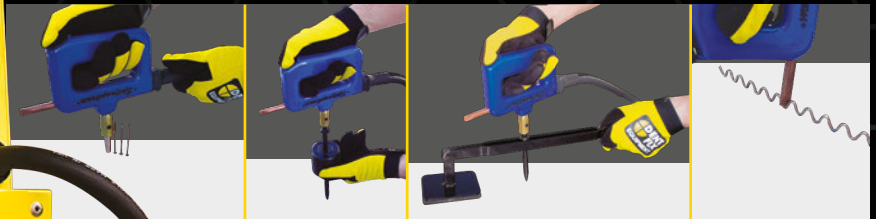

Its all in the handle  
**WELD • PULL • TWIST**



Optional  
Storage  
Stand  
DF-509

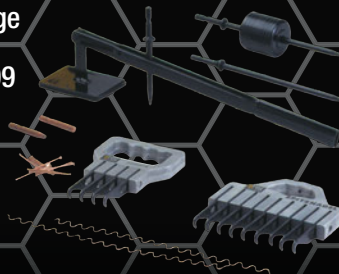

VINTAGE  
MAXI VIDEO



Phone **800.523.1751**  
Web **DENTFIX.COM**  
Twitter **@DENTFIXEQIP**  
Facebook **/DENTFIXEQUIPMENT**  
Visit us at ISN booth # 1244

Enter 110 at "e-inquiry" on vehicleservicepros.com

# DF-TRG1314

The logo for DENT FIX EQUIPMENT is centered in the upper half of the page. It features a stylized yellow and white circular icon on the left, composed of two semi-circles. To the right of the icon, the words "DENT", "FIX", and "EQUIPMENT" are stacked vertically in a bold, white, sans-serif font. The entire logo is set against a dark grey rounded square background with a subtle glow and a yellow arc with a starburst effect on the right side.

**DENT  
FIX  
EQUIPMENT**

Technical  
Reference Guide **13-14**

# FUTURE SUCCESS STARTS TODAY



## DF-505

MAXI MULTIPLE PULL DENT STATION

The ultimate dent pulling station

Can do pins, wiggle wire, pull rods and shrink

Its all in the handle: **WELD • PULL • TWIST**



**NEW**

Mini Venturi Gun



**DF-BG601**

**NEW**

Venturi Blow Gun



**DF-BG600**

Maxi Stand



**DF-509**

Surge Protector



**DF-601A**

**NEW**

Mini Blow Gun



**DF-BG602**

Spot Weld Drill



**DF-15DX**

**NEW**

Micro Weld Clamps



**DF-MC201**

**NEW**

Butt Weld Clamps



**DF-BC200**



Phone **800.523.1751**  
 Web **DENTFIX.COM**  
 Twitter **@DENTFIXEQIP**  
 Facebook **/DENTFIXEQUIPMENT**



**VINTAGE  
MAXI VIDEO**

## Where do I find?

---

<b>Panel Removal</b>	<b>4-5</b>
<b>Dent Removal: Steel</b>	<b>6-7</b>
<b>Welding - Clamps, Pliers &amp; Surge</b>	<b>8-9</b>
<b>Dent Removal: Aluminum</b>	<b>10-13</b>
<b>Hole Punching</b>	<b>14</b>
<b>Grinding &amp; Cutting</b>	<b>15</b>
<b>Measuring</b>	<b>16-17</b>
<b>Undercoating, Decal &amp; Sanding</b>	<b>18-19</b>
<b>Plastic Repair</b>	<b>20-21</b>
<b>PDR - Paint Less Dent Repair</b>	<b>22</b>
<b>Shop Tools</b>	<b>23-24</b>
<b>Wedge &amp; Scraper</b>	<b>25</b>
<b>Detail &amp; Polishing</b>	<b>26</b>

## More Information

SUBSCRIBE TO OUR  
**NEWSLETTER**  
[WWW.DENTFIX.COM](http://WWW.DENTFIX.COM)

<b>WEB</b>	<b><a href="http://www.DentFix.com">www.DentFix.com</a></b>
<b>BLOG</b>	<b><a href="http://www.DentFixGold.com">www.DentFixGold.com</a></b>
<b>YOUTUBE</b>	<b><a href="#">/DentFixEquipment</a></b>
<b>FACEBOOK</b>	<b><a href="#">/DentFixEquipment</a></b>
<b>TWITTER</b>	<b><a href="#">@DentFixEquip</a></b>
<b>PHONE</b>	<b>800.523.1751</b>
<b>INTERNATIONAL</b>	<b>310.349.1940</b>
<b>EMAIL</b>	<b><a href="mailto:info@dentfix.com">info@dentfix.com</a></b>
<b>FAX</b>	<b>310.349.1191</b>
<b>MAIL</b>	<b>1611 W. 135th St. Gardena, CA • 90249</b>

# PANEL REMOVAL



## Spot Annihilator Deluxe Kit DF-15DX

- No slam soft approach
- Applies proper cutting pressure
- Quick c-clamp disconnect

### Kit Includes

- x4 - Drill Bits
- x1 - Inline Oiler & Oil
- x1 - Allen Wrench
- x1 - Blow Molded Case



## Spot Annihilator Drill Bits

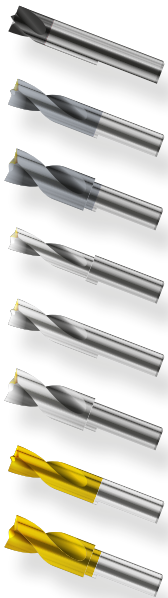

Part #	Type	Coated	Size	Feature	Speed
DF-1690	Tungsten-Carbide	Friction-Free Multi-layered	8mm x 45mm	For Boron Steel, UHSS & Usibor / Triple Fluted	1000 rpm
DF-1680TC	High Speed Cobalt (HSCo)	Titanium Carbon Nitride	8mm x 45mm	Harder Edge / Lower Friction	High Speed
DF-1610TC	High Speed Cobalt (HSCo)	Titanium Carbon Nitride	10mm x 45mm	Harder Edge / Lower Friction	High Speed
DF-1465	High Speed Cobalt (HSCo)	n/a	6.5mm x 45mm	Heat Resistant / Centering Nib	High Speed
DF-1480	High Speed Cobalt (HSCo)	n/a	8mm x 45mm	Heat Resistant / Centering Nib	High Speed
DF-1610	High Speed Cobalt (HSCo)	n/a	10mm x 45mm	Heat Resistant / Centering Nib	High Speed
DF-1680T	High Speed Cobalt (HSCo)	Titanium Nitride (TiN)	8mm x 45mm	Lower Friction / Heat Resistant	High Speed
DF-1610T	High Speed Cobalt (HSCo)	Titanium Nitride (TiN)	10mm x 45mm	Lower Friction / Heat Resistant	High Speed

PANEL REMOVAL

### Cup & Screw



DF-SPD66A

### 6" Mega C-Clamp



DF-SPD48M

### Weld Breaker



DF-17 Hammer not included

## Spot Weld Drill Bits for 3/8" Drill Chuck

Part #	Type	Coated	Size	Feature	Speed
<b>DF-1780</b>	High Speed Colbolt (HSCo)	n/a	8mm x 80mm	Heat Resistant / Centering Nib	High Speed
<b>DF-1780T</b>	High Speed Colbolt (HSCo)	Titanium Nitride	8mm x 80mm	Lower Friction / Heat Resistant	High Speed
<b>DF-1667</b>	Tungsten-Carbide	Friction-Free Multi-layered	6.7mm x 80mm	For Boron Steel, UHSS & Usibor / Triple Fluted	1000 rpm

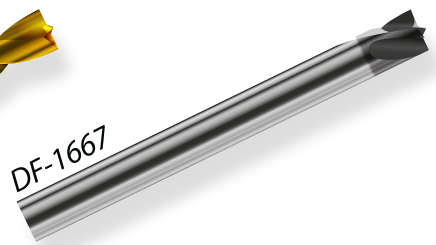
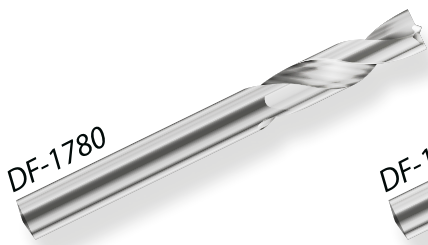

Extend Reach 6.5"

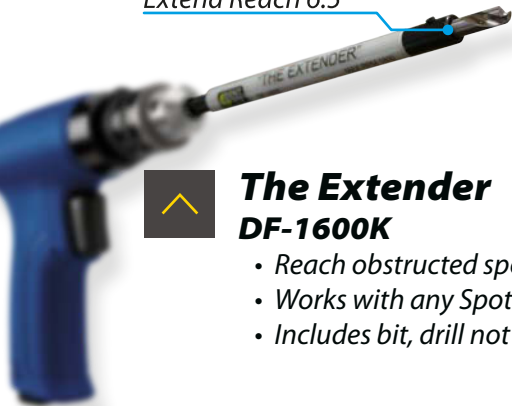

### The Extender DF-1600K

- Reach obstructed spot welds
- Works with any Spot Annihilator bit
- Includes bit, drill not included



### Laser Weld Cutter



### Laser Weld Cutter DF-i9209

- Remove long linear laser welds
- Depth adjustable
- Distance guide



### Rivet Drill DF-5125P

- TYX coated 6.8 (DF-51268) & 4.3mm (DF-51243) bits
- Centers on the rivet
- Specialized for BMW rivet as well as other types

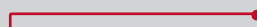

### Laser Weld Spurs (included)



**DF-i9209CB**  
Steel



**DF-i9209CBA**  
Aluminum

# DENT REMOVAL

# STEEL



**Made In USA**  
**WARRANTY 5 YEAR**

## < The Maxi DF-505/220V

- The ultimate dent pulling station
- Can do pins, wiggle wire, pull rods & shrink
- Its all in the handle: WELD • PULL • TWIST



**THE MAXI**  
Multiple Pull Dent Station

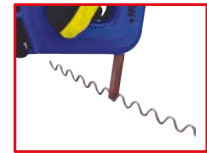
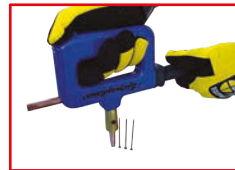

## < Stand DF-509

- Available separately

## TOTALSTIK

Conical designed heads  
weld 37% STRONGER



## < Stud Weld Pins TotalStik

- Flexible steel core
- Copper coated
- 2.0mm rated to 400lbs
- 2.6mm rated to 600lbs

## ✓ Wiggle Wire 1/2 lb

- DF-508 - Thin Wire
- DF-508TK - Thick Wire

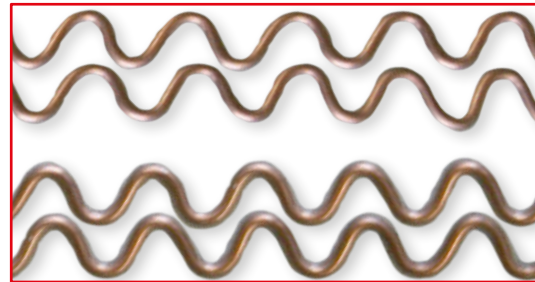

## ✓ Wiggle Wire 1 lb

- DF-507 - Thin Wire
- DF-507TK - Thick Wire

**STEEL**



TotalStik	2.0 mm	2.6mm
x1000	DF-20	DF-26
x500	DF-20/500	DF-26/500
x250	DF-20/250	DF-26/250



### **The Shark DF-595ii**

- 110v multi-pull dent removal welder
- All the essentials for higher productivity pulls
- Available from select distributors



### **Flexible Fender Puller DF-HD0140**

- Shapes to fender curve
- Pulls 1.5 ton
- Pulls core supports

**Flexible  
FENDER  
PULLER**

*Hinged claws curve  
around the fender*



*Sold individually*



### **Ring Hammer DF-903**

- 3 hammer heads
- Fast easy to use multi-tool
- Fits to the first knuckle



### **Heavy Duty Claw DF-512**

- Heavier wiggle wire pulls
- Power post pulls
- Pull wider areas



### **Bear Claw Slide Hammer DF-545**

- Use with the frame claw
- 4.15 pound slide weight
- Quality construction



## REPLACEMENT PARTS

#### **DF-505**

*9 Finger Bear Claw*

*DF -506*

*4 Finger Bear Claw*

*DF -504*

*Bear Claw Finger*

*DF-503F*

#### **DF-512**

*Claw Finger*

*DF-512F*

**STEEL**

**7**

# WELDING

**ANCHOR BITE**  
FABRICATION PLIERS

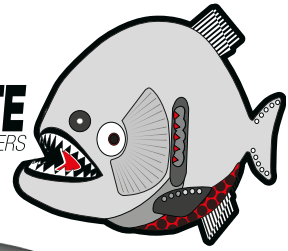

Quick Release Handle



## **Fabrication Pliers - Snub** **DF-LP22**

- Snub nose design
- 4 position instant opening adjustment
- Quick release lever



## **Fabrication Pliers - Long** **DF-LP23**

- Longer nose design
- Large gripping surface
- 4 position instant opening adjustment

4 Position Adjustment

Wide Opening



## **Fabrication Pliers - Swivel Tip** **DF-LP24**

- Widest gripping angle
- Swivel head adjusts to large openings
- 4 position instant opening adjustment



Includes 4 Pieces



### **Butt Welding Clamps** **DF-BC200**

- Holds panels together with minimal gap
- Level adjust for different metal thicknesses
- Essential for proper mig brazing



Includes 4 Pieces



### **Micro Welding Clamps** **DF-MC201**

- Generate strong clamping force relative to size
- Position and secure panels for pinch/spot weld
- Open from 0 to 7mm with flex joint tips



Back



Front



### **Ground Magnet** **DF-GM**

- Strong hold
- 350 amp rated
- Durable construction



### **Ground Vise Grip Clamp** **DF-GC**

- Will not pull off
- Use on panel edges
- Will not gather metal particles



### **Surge Protector** **DF-601A**

- Protect vehicle electronics
- Greater protection against surge
- Lifetime warranty



# WORKING WITH ALUMINUM

13

26.98

Al

Aluminum

Vehicle manufacturers are producing more models with this beneficial metal everyday. Demand for aluminum repair has increased rapidly in recent years and will

continue to do so. Already 30% of all the hoods and over 20% of the bumper beams are aluminum. Body, bumper & closure parts account for 58% of the aluminum content growth from 2009 to 2012. Shops eager to capitalize on this market need to do two things: learn how to work with aluminum and re-tool with tools specific to this type of repair. Lighter can result in better mileage, smaller engines moving less mass and greater acceleration. US Governmental initiatives have accelerated the weight loss of production vehicles by mandating the Corporate Average Fuel Economy (CAFE) standards of 54.5 mpg by 2025.

## Things to Know

Aluminum behaves differently than steel. Change the shape of a steel part; it remembers the form it used to be in. The opposite is true when working with aluminum. Once it is reshaped, it forgets its original form and will take on a new shape.

It is a work hardened material. When aluminum is stamped into shape it becomes stronger. After the panel is bent in a collision it becomes stronger still. Flex it too much and it breaks or cracks like a bent spoon. In order to repair and pull the damaged area, the panel must be heated to 400°F to allow the metal to soften. Aluminum dissipates heat very quickly, but can become permanently changed if heated past a certain point, approximately 570°F. The heated panel can now be pulled and while pulling the material it is being work hardened to set the new memory.

A thin coating of aluminum oxide forms after being exposed to the air in as little as 15 minutes. This oxidation has a much higher melting temperature than the original aluminum material and a stud will not fuse correctly to the panel. Aluminum's melting point is 1,200°F and aluminum oxide is 3,725°F. The oxide can be removed using a stainless steel brush.

Galvanic corrosion (left) will occur when a less "noble" metal like aluminum, comes in contact with a more "noble" metal like steel, in the presence of an electrolyte such as water. The aluminum will corrode around the steel contamination, ruining the paint finish. In order to avoid contamination a separate set of working tools and dedicated work area must be maintained. Steel bolts, screws or rivets should not be used when in direct contact with aluminum unless properly coated.



## Identification of Aluminum

A quick method is to use a magnet, it will not be attracted to an aluminum panel. There are alloys and different manufacturing methods that determine the series of aluminum. It is a good idea to refer to the manufacturer literature for series identification of cast and panel pieces. In all cases manufacturer methods and guidelines on whether to repair or replace should be always followed. However, not all companies make this information available. Another great resource to utilize is the internet, but only use reliable sources. Once it is determined that the damaged part is made of aluminum and repairable, the next step is to understand what the 4 digit series means.

## Four Digit Series

Aluminum alloys are designated into 4 digit series based upon the main element used in combination of the aluminum. The most common use for automotive applications are 5000 and 6000 series which mostly contain Magnesium and Silicon. Any number that follows the first digit identifies the percentage of alloying agent used. These alloys are further classified as Heat-Treated and Non-Heat-Treated. This means that during the manufacturing process they have the ability to gain strength from being exposed to elevated temperatures or from being stamped or bent. Please refer to the Four Digit Series Chart on the next page.

## Selecting the Appropriate Tools

First thing you will need is an abrasive grinding disc, inline removal tool and stainless steel brushes to remove the paint and oxide coating. To shape the metal it must be softened. Heat to the to the appropriate temperature with a digital temperature set heat gun for heat control. Aluminum has a high thermal conductivity and heat travels throughout the panel rather than in a concentrated spot. It is critical to maintain a temperature range of 400-500°F. Some technicians use the aid of coworker to heat the area while the other uses the dent pulling



## Four Digit Series Chart

### Aluminum Alloys

Alloy	Main Element
1000 Series	99% Pure Aluminum
2000 Series	Copper
3000 Series	Manganese
4000 Series	Silicon
5000 Series	Magnesium
6000 Series	Magnesium/Silicon
7000 Series	Zinc

5000 & 6000 are the most common automotive applications.

#### Strengthening Methods:

- ▶ **Heat-Treatable**  
Exposed to elevated temperature, stamped and/or bent
- ▶ **Non-Heat-Treatable**  
Stamped or bent

# 6061-T4

## T4- Solution Heat-Treated And Naturally Aged

Many vehicle makers use 6000 series aluminum that is T4 for initial stamping of vehicle exterior parts. T4 is obtained by heating aluminum up to 480°C (900°F), quenching, and then aging at room temperature for 16-24 hours.

### Temper Designations

Used to identify how aluminum is strengthened during the manufacturing process.

"T" = Thermally Hardened (Heat-Treated Alloys)  
2000, 6000 & 7000 Series

"H" = Strain Hardened (Non-Heat-Treated Alloys)  
1000, 3000, 4000 & 5000 Series

Bake Hardening process further increases temper and requires elevated temperatures for a specific amount of time. For example, Aluminum alloy 6016 is increased to T6 by bake-hardening for 30 minutes at 205°C (400°F).

tool. If you go above 570°F the structural rigidity of the part could be permanently annealed. A good tool to monitor temperature is an infrared thermometer that determines surface temperature without having to touch anything to the aluminum. Infrared has difficulty with reflective surfaces so measurements must be taken off a nearby painted surface or use a permanent marker. Heat indicating crayons can also be used if an accurate reading is not being obtained. Visual cues like color change in the metal are non-existent when aluminum is heated.

Once you have prepped the damaged area by heating to the appropriate temperature, repair techniques are similar but differ subtly from steel. Weld on dent pulling can still be performed as long as you have the appropriate tools. A Capacitor Discharge Welder (CDW) is needed to overcome the high thermal conductivity property of the aluminum and fuse the stud to the surface. It must produce a higher level of power and deliver it more rapidly than a traditional stud welder. An important factor to consider when selecting a CDW is to look at how the unit is grounded. When working on a dent at the center of an aluminum hood, less desirable units with wire grounds require two exposed metal areas near the edge as ground points. More work is now needed to prepare and later properly blend the repair in three separate locations with the rest of the hood and fenders. Look for the grounds to be on the front of the gun on both sides of the electrode. This eliminates extra areas to blend and less work in general; a benefit everyone can appreciate.



Once the studs are attached a T-Puller, Bridge Puller and Squeeze Puller offer a wide range of pulling options. The puller used is determined by the location and depth of the repair area, but in general the squeeze puller is the most commonly used. Squeeze pullers allow for a massaging mo-

tion to work the damage out and this puts work hardening back into the panel. If necessary the puller can be locked in position and the panel reheated then massaged back to hardness. The repair can be further smoothed by using a hammer and off dolly technique. Dollies best suited for this include rubber, POM (polyoxymethylene) Nylon, highly polished steel and metal bearing filled "beanbags". Body files can be used to remove any residual stud stumps.

It is critical to prevent galvanic corrosion when working with this unique metal. The best method of prevention against contamination is to keep tools that are used for aluminum work separate from tools used on steel. A separate enclosed storage cart should be used. Besides contaminated tools, another factor to consider is accidental airborne contamination. Metal is often kicked into the air by sanders, grinders and cutters from other locations in the repair facility. Curtain walls, at a minimum, are needed to separate the work area. The enclosed tool kits keep the particles and debris out of the station and away from the tools. A mobile cart allows every tool needed for the job to be transported to the desired location in one trip.

A well thought out system organizes all the tools needed. Foam drawer cutouts eliminate misplaced tools. Each tool has its own place and can be easily identified when it is missing. This system locks away to maintain the integrity of the repair process.

### Conclusion

Aluminum repair is not new but is becoming much more prevalent. It used to be higher end manufacturers who used aluminum; not true today. The thing to remember is that lightweight is the name of the game and more aluminum panels and components are showing up on an increasing number of mass produced models from all over the world. Shops can either ignore the increase demand, at their own peril, or capitalize on the repairs most other shops cannot do.



## Aluspot : Aluminum Repair Station DF-900A & DF-900DX

- Everything you need for aluminum repair
- Repair rates are up to 3x that of steel
- Lockable system keeps tools organized, clean and safe



Organized Drawers



## Rubberized Dolly Set DF-AB711

- Steel core dolly with a dense rubber covering absorbs the impact
- Less bounce back than steel dollies
- Perfect for aluminum work



## 12 Piece POM Dolly Set DF-AB712

- Made of polyoxymethylene (POM)
- Rigid yet non-marking touch on metal
- High abrasion resistance & non-corrosive interaction with aluminum



## Laser Weld Cutter DF-i9209

- Remove long linear laser welds
- Depth adjustable
- Distance guide



## Stainless Steel - Fine DF-702SF

- Best suited for aluminum & fiberglass
- More aggressive DF-702SM
- Use with DF-700T



## DF-900A

**Capacitor Discharge Welder  
DF-900W**



**Alu-Magnesium Stud Pins  
DF-900PM**



**Hand T-Puller  
DF-900TP**



**Squeeze Puller  
DF-900SP**



**Lever Puller  
DF-900LP**



**Body File + 350m Blade  
DF-900BFH + DF-900BFB**



**Infrared Temperature Gauge  
DF-900IT**



**Digital Temp Heat Gun  
DF-900HG**



**Pick and Finishing Hammer  
DF-900PFH**



**Curved Pein & Finishing  
DF-900CPH**



**22mm Soft Face Hammer  
DF-900SFH**



**Reverse Curve Hammer  
DF-900RCH**



**35mm Dead Blow Hammer  
DF-900DBH**



**Bolster Head Nylon Chisel  
DF-900BHND**



**Round Head Nylon Chisel  
DF-900RHND**



**Double End Nylon Dolly  
DF-900DEND**



**Utility Dolly  
DF-900UTD**



**Double End Dolly  
DF-900DED**



**Thin Toe Dolly  
DF-900TTD**



**Heel Dolly  
DF-900HLD**



**Curved Dolly  
DF-900CVD**

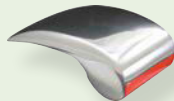

**Inline Paint Remover  
DF-700T**



**Stainless Steel Shoe Handle Brush  
DF-900SSB**



**Stainless Steel Tooth Brush  
DF-900SSBS**



## DF-900DX Everything from DF-900A plus:

**Bridge Puller  
DF-900BP**



**3rd Drawer  
DF-900BD**



**Dust Cover  
DF-900DC**



# HOLE PUNCHING

## ✓ **Punch and Flange Pliers** **DF-516PF**

- Swivel head for flanging
- Cuts up to 18 gauge steel
- Produces a 8.0mm hole
- Available in 4.5mm hole (DF-316PF)



## ✓ **5/16" Hole Punch Pliers** **DF-516**

- Heavy duty depth adjustable pliers
- Cuts up to 18 gauge steel
- Produces a 8.0mm hole

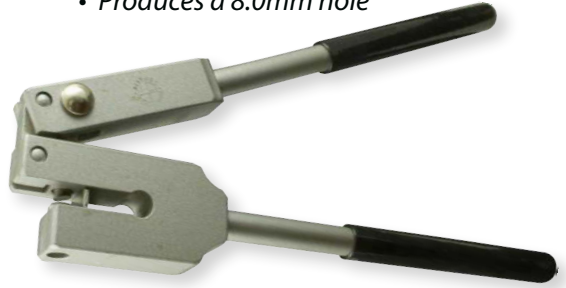

## ✓ **1/4" Hole Punch** **DF-8**

- Deep Throat
- Hole size leaves room on panel edge
- Easily cuts up to 18 gauge steel
- Produces a 6.5mm hole

## ✓ **6-in-1 Pneumatic Punch/Flange Kit** **DF-MP050K**

- Interchangeable heads
- 4.0, 5.5, 6.5, & 8.0mm punch heads
- Flange head and deep 8.0mm punch head



## REPLACEMENT PARTS

**DF-516PF**  
5/16" (8.0mm) Die  
DF-516PFDS

**DF-316PF**  
3/16" (4.5mm) Die  
DF-316PFDS

**DF-516**  
5/16" (8.0mm) Die  
DF-516DS

**DF-8**  
1/4" (6.5mm) Die  
DF-8DS

**DF-MP050K**  
8.0mm Deep Punch  
DF-MP050DT

# GRINDING & CUTTING



## ✓ Reversible Air Cut-Off Wheel DF-i9314

- Reversible motor & shield
- Flip tool in tight spots
- 15,000 RPM, 6.3 bar, 90 PSI Max



## ✓ Long Corner Grinder DF-i9315CR

- Small face for tight corners
- Long reach handle allows two handed use
- 15,00 RPM, 6.3 bar, 90 PSI

# MEASURING

## ✓ **Digital Measuring Tram** **DF-3DX**

- Easy read digital display
- Long measuring range
- Measures from 1'4" to 11'11"



**TRAM**  
**GAUGES**  
"Measure Up to Be The Best"



- x2 - 350 mm Pointers
- x3 - 110 mm Pointers
- x2 - Cone Pointers
- x2 - Bullet Pointers
- x2 - Pointer Holders
- x4 - AA Batteries
- x1 - Blow Molded Case



- x2 - 350 mm Pointers
- x2 - Cone Pointers
- x2 - Right Angle Pointer
- x2 - Bullet Pointers
- x1 - Nylon Storage bag



DF-121



DF-120

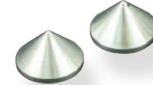

DF-1180

## ✓ **Telescoping Tram Gauge** **DF-3**

- Accurate to +/- 1.0mm
- Storage bag for tool and accessories
- Extends from 3' to 10'6"

## < **Tram Shortener** **DF-311**

- Creates new measuring point
- Takes shorter measurements
- Fits the DF-3



## ✓ **Mini Tram Gauge** **DF-3S**

- Accurate to +/- 1.0mm
- Short to access small areas
- Measures from 16.5" to 3'3"



- x2 - 350 mm Pointers
- x2 - Cone Pointers
- x2 - Right Angle Pointer
- x2 - Bullet Pointers
- x1 - Nylon Storage bag

✓ **5 Meter Tram Gauge**  
**DF-3TC5A**

- Read the internal tape through the display
- Extruded aluminum frame is lightweight
- Measures from 3'6" to 15'4"

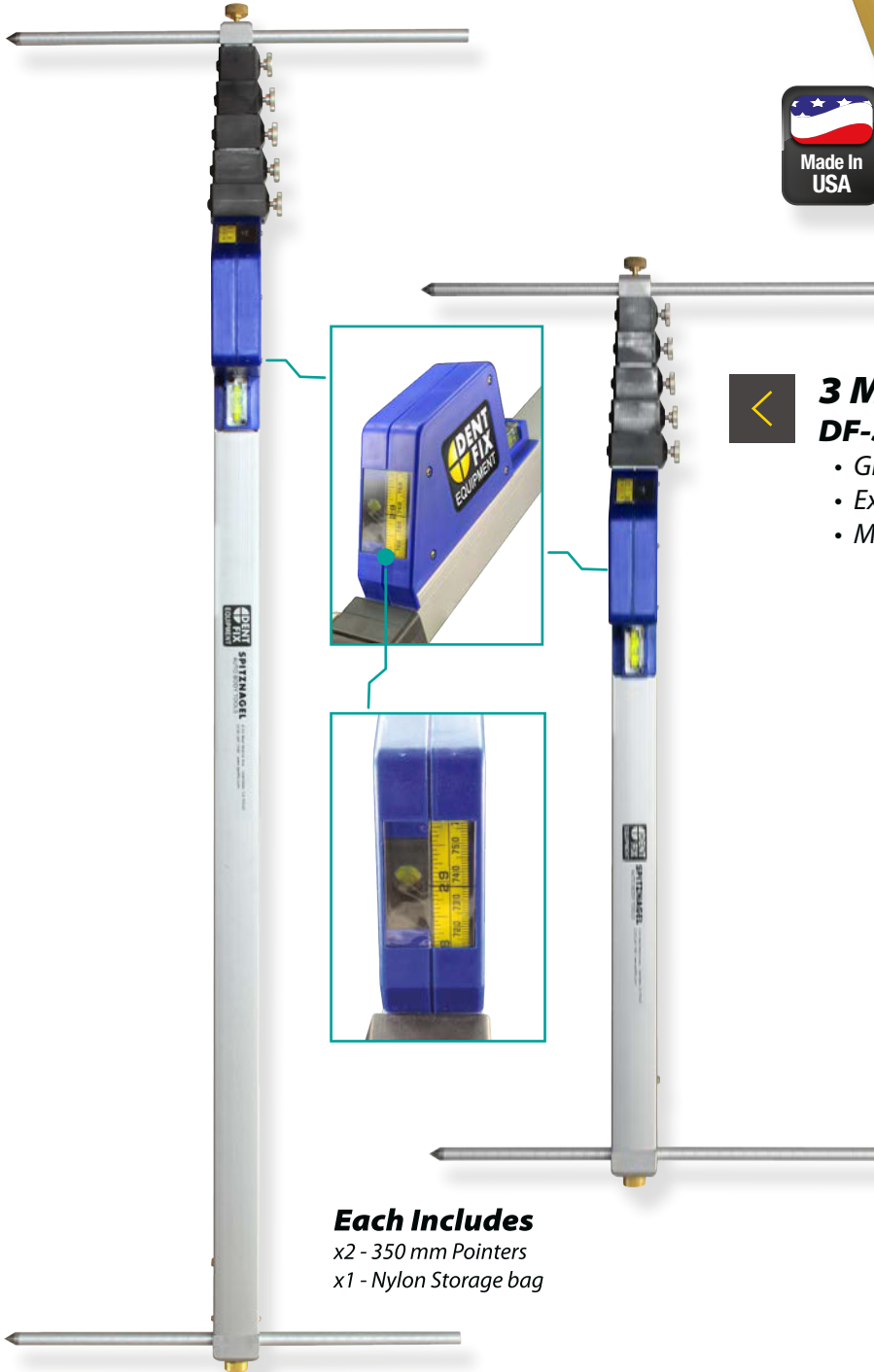

**Each Includes**  
x2 - 350 mm Pointers  
x1 - Nylon Storage bag

✓ **Body Line Tool**  
**DF-BL10A**

- Re-create fender curve line
- Accurate measurements
- Quick and easy



✗ **3 Meter Tram Gauge**  
**DF-3TC3A**

- Great for writing estimates
- Extend out only as much as needed
- Measures from 2'6" to 9'2"

## REPLACEMENT PARTS

**DF-3 & DF-3S**

350mm Pointer

DF-118

280mm Pointer

DF-118A

Cone Pointer

DF-1180

Bullet Pointer

DF-120

Short Angle Pointer

DF-121

**DF-3DX**

700mm Pointer

DF-309

350mm Pointer

DF-301

110mm Pointer

DF-302

# UNDERCOATING



**ELIMINATOR**  
INLINE UNDERCOAT AND DECAL REMOVER

## Eliminator Kit DF-700DX

- Inline undercoat and decal remover
- Also strips rust, paint, seam sealer or gaskets
- Easy, fast way to get the job done
- Available tool & hub only set (DF-700T)



## Decal Eraser DF-705

- Softest touch for decal removal
- The original style



## Offset Decal Eraser DF-705D

- Heavy duty decal remover
- Last longer without burning the paint



## Coarse Brush DF-702C

- Used for removing undercoating
- 11mm also available DF-702C11

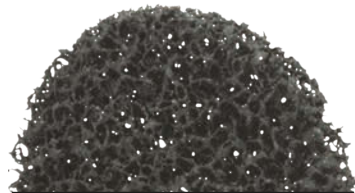

## Fiber Discs DF-710BW

- Large area paint removal
- Pack of 6 discs



**Stainless Steel - Fine  
DF-702SF**

- Best suited for aluminum & fiberglass
- More aggressive DF-702SM



**Right Angle Undercoat Remover  
DF-701**

- Popular alternative to inline version
- Variable speed control for erasers & brushes
- Includes x3 DF-702C & x1 DF-705



**Sand Box  
DF-SB100**

- Protects adhesive paper from dust & moisture
- Streamline inventory control
- Includes handle or can be wall mounted



**Kool-Cut Sander  
DF-C3812**

- Clear view of work area
- Scoops air to cool panel
- Prevents heat warping while sanding

**REPLACEMENT  
PARTS**

**DF-700DX**

23mm Hub  
DF-702H23



**11mm Hub**

DF-702H11

**Single Disk Hub**

DF-710BHS



**Double Disc Hub**

DF-710BHD

**Drive Belt (Orange Ring)**

DF-700/34

**Drive Belt (Red Ring)**

DF-MBXPT51R

**Drive Belt (Blue Ring)**

DF-MBXPT51B

Sold Individually

# HOT STAPLERS



## < Deluxe 110v Kit DF-800BR

Repair thermoplastic parts instead of replacing. Taylor crafted to be compact, light-weight and ergonomic. This easy to use plastic repair tool can pay for itself in one use.

Also Includes:

- x1 Case,
- x1 Finishing Iron
- x5 Filler Tubes
- x350 StapleClips (7 Styles, 50 each)



## ▲ Premium NiMh Cordless Kit DF-850CL

- Up to 350 staples on a full charge
- Perfect fit for the tech on the move
- 7 styles, 350 StapleClips included



## ▲ Basic Kit DF-400BR

- 3 Heat Seatings
- 1 Year Warranty
- 4 styles, 250 StapleClips

## Replacement Plastic Fill Rods

**Fiber Flex Rods: DF-800FF**

**Fill Rods: DF-800FR**

PLASTIC

20

# HOW TO USE A HOT STAPLER

Save thermoplastic bumpers, motorcycle fairings, headlight assemblies, plastic interior components, hanging and mounting clips under hood or any other part by stitching them together with the Hot Stapler Kit. These tools add a structural element to cosmetic repairs. The StapleClips put the original strength back into the part, so now you save parts that would have been thrown away before. Breakaway StapleClips save you the time and hassle of grinding. No more cracking or breaking a part you spent time repairing. Last minute fixes are no longer a headache. This tool makes you money from day one.

READ MORE AT [DENTFIXGOLD.COM](http://DENTFIXGOLD.COM)

Insert StapleClip leads into Hot Stapler prongs

Hold down the trigger and the StapleClip heats up rapidly. Do not sink too deep.

Bridge the gap of the repair and provide a twist, if needed.

The Breakaway StapleClip leads are notched allowing them to be removed by hand

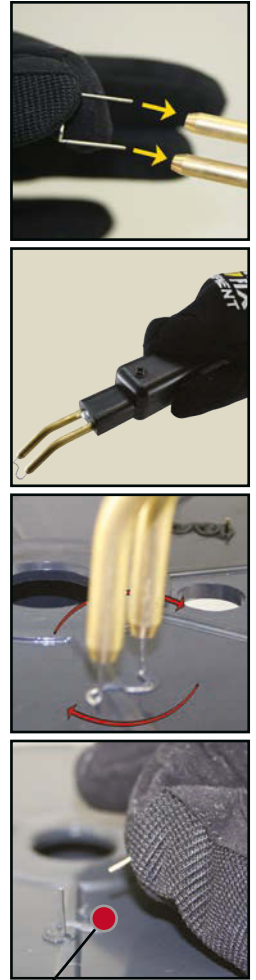

HOW TO USE

## BREAKAWAY<sup>®</sup> STAPLECLIPS<sup>®</sup>

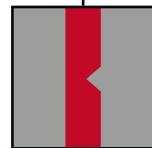

Notched leads

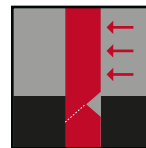

Remove lead

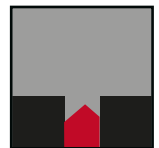

No need to grind the stump

**M-Clip:**  
Outside Corner

**S-Clip:**  
Outside Tears

**Z-Clip:**  
Stitch Tabs

**U-Clip:**  
Rounded Corner

**W-Clip:**  
Grip Corner

**V-Clip:**  
Inside Corner

**N-Clip:**  
High Vibration

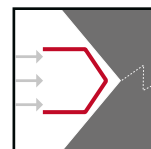
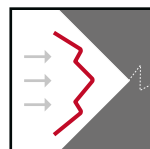
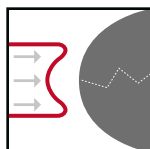
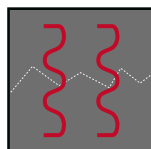
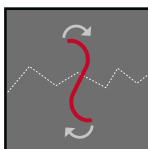
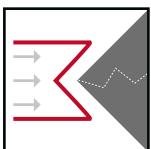

DF-800MC/50



DF-800SC/50



DF-800ZC/50



DF-800UC/50



DF-800WC/50



DF-800VC/50



DF-800NC/50

PLASTIC

# PAINTLESS DENT REPAIR



## **Ding Messenger Deluxe** **DF-DM550DX**

- Repair dings, dents, hail and damage
- Glue pullers are the easiest means of PDR
- The most complete kit on the market

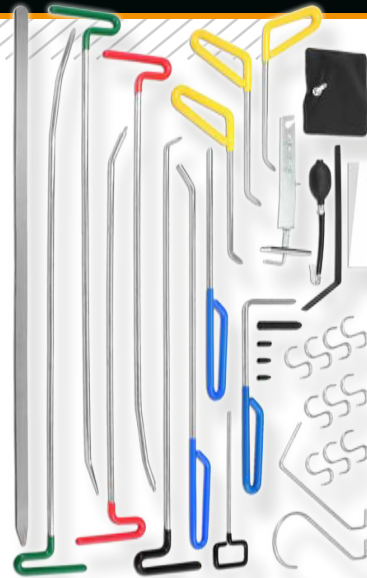

## **33 Piece PDR Kit** **DF-PDRKIT33**

- Massage out dings, dents & creases
- Stainless steel rods
- Interchangeable plastic tips

## REPLACEMENT PARTS

### **DF-DM550DX**

Glue Sticks

DF-DM520GS (Amber)

DF-HS10 (Yellow)

DF-PG10 (Red)

Plastic Nibs

DF-DM520DT (Variety)

DF-DM521/ONS (34x22mm)

DF-DM521/ONM (40x27mm)

DF-DM521/ONL (48x32mm)

DF-DM521/RNS (30mm)

DF-DM521/RNM (35mm)

DF-DM521/RNL (40mm)

DF-DM521/CNS (15mm)

DF-DM521/CNM (20mm)

DF-DM521/CNL (25mm)

T-Bar Slide Hammer

DF-530SH

Squeeze Puller

DF-540SP

## **Sweet Spot PDR Kit** **DF-PDRSP**

- Magnetic roller tip with guide ball
- Follow the ball to know where you are
- 3 bars, 3 tips, guide balls & accessories
- Helps novices progress to experts



## **Plastic Nibs**



Oval

Round

Convex

## **Ding Boards** **Two Styles**

- Yellow: DF-DM510DBY
- White: DF-DM510DBW
- High visibility/contrast



# SHOP TOOLS



## **Slimline Plastic Riveter**

**DF-CT887**

- Easily installs plastic rivets in a snap
- Short 1" pliers head is perfect for narrow openings
- Only needs 2" clearance to fully apply rivets



## **Turbo Venturi Blow Gun**

**DF-BG600**

- Pistol grip handle
- Venturi tip is more powerful & safer
- Large trigger for comfortable operation



## **Mini Blow Gun - Rubber**

**DF-BG602**

- Provides a concentrated stream of air
- Compact design can fit in a pocket
- Includes carabineer for belt loop



## **Mini Blow Gun - Venturi**

**DF-BG601**

- Compact design is highly portable
- Venturi tip is more powerful & safer
- Includes carabineer for belt loop

## THINGS TO KNOW **VENTURI TIP**

The Venturi Tip speeds up the main air flow by drawing ambient air from the side ports, thus increasing velocity and volume thus boosting the available thrust up to 250%. If the tip is blocked the blow back is released through side

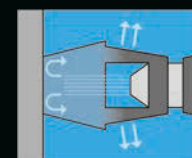
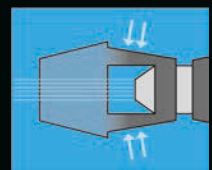

ports and static pressure is held to less than 30 psi; which satisfies OSHA safety standards.



DF-DPS1 in use



**Door Prop Stick  
DF-DPS1**

- Lock door, hatch or hood in one position
- Three adjustment settings
- Works great for PDR and broken hinges



Shown with optional DF-613RH

**Multi-Handle Driver  
DF-615**

- T, Pistol or Angled grip
- Reach past tight areas
- S2 quality 98 piece bit set



DF-WK20 in use



**Windshield Scraper  
DF-WK20**

- Perfect for glass
- Door wedge & molding removal
- Non marring, high quality nylon



**Rotational Finger Brush  
DF-FB100**

- Thoroughly cleans hands after a dirty job
- Removable brush unfolds for large areas
- Comfortably fits in the hand



Sold individually

**Finger Ratchet Adapter  
DF-613RH**

- Compact & fits into tight spaces
- Can be used with DF-615
- 1/4" drive

# WEDGE & SCRAPER



## Trim Panel Scraper Set DF-620TPS

- 12 piece panel removers & scrapers
- Easily & safely remove trim pieces
- Organized in a rugged canvas pouch



## Trim Panel Popper Set DF-621TPS

- 12 piece panel & clip removers
- Includes mini dead blow hammer
- Stored in a blow molded case



## 27 pc Deluxe Trim Scraper Set DF-623TPS

- Versatile collection of trim panel removers
- Easily remove pieces clipped to a panel
- Kit includes sturdy canvas pouch



## Razor Scraper DF-608

- Versatile set of blade widths and angles
- Two handles ensures efficient service
- Ergonomic design



## Utility Wedge Set DF-609

- Door wedge & molding removal
- High quality, non marring nylon
- 30 & 60mm wedge and clip tool

# DETAIL & POLISH

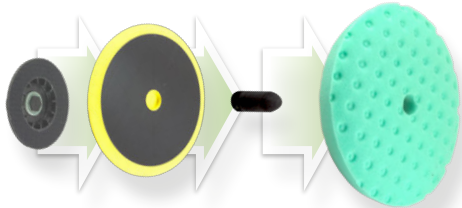

Polishing pad not included

## Polishing Pad Storage System DF-2200

- Magnetized backing sticks pad to metal surface
- Quickly change polishing pads
- Keep pads out of the way & protected



## Tornador Pulse Cleaning Gun - Reservoir DF-Z010

- Excellent soft surface cleaning
- Pulse action efficiently delivers additives in a fine mist
- Available with a brush cone nozzle, instead of cone DF-Z010B



## Tornador Pulse Cleaning Gun DF-Z014

- Excellent soft surface cleaning
- Pulse action efficiently delivers additives in a fine mist
- Also available with a brush cone nozzle DF-Z014B



## REPLACEMENT PARTS

**Tornador**  
Weighted Tube  
DF-SPZ01003

Cone  
DF-SPZ010002A

Cone with Brush  
DF-SPZ010002B

Stainless Steel Insert Cone  
DF-SPZ010002S



## Instant Foam & Snow Gun DF-Z011

- Generates suds for gentle application
- Apply to high profile vehicles
- Complete coverage with no waste

# BORON KILLERS

Spot Welds Beware



**PREDATOR APPROACH**

No More Bit Slamming

## DF-15DX\*

SPOT WELD DRILL KIT

The depth adjustable drill will not damage underlying panels

Only approved drill to be used with DF-1690



## DF-1690

STC TUNGSTEN CARBIDE

Intended for Boron Steel and Ultra High Strength Steel

x1000 RPM maximum



Triple Flute

8.0x45mm

Boron Killer  
Made in Germany

### REPLACEMENT DRILL BITS

DF-1480	8.0 MM HSCO
DF-1465	6.5 MM HSCO
DF-1610	10 MM HSCO
DF-1610T	10 MM Titanium
DF-1680T	8.0 MM Titanium
DF-1680TC	8.0 MM Titan./Carbo

### ACCESSORIES PARTS

DF-SPD48M	Mega Clamp
DF-SPD66A	Cup & Screw

\* DF-15DX Kit Includes: x2 DF-1680T, DF-1610T, DF-1480, DF-150IL & DF-15INOIL. The DF-1690 is sold separately.

**DENT  
FIX**  
EQUIPMENT

Phone **800.523.1751**  
Web **DENTFIX.COM**  
Twitter **@DENTFIXEQUIP**  
Facebook / **DENTFIXEQUIPMENT**



**SPITZNAGEL**  
SPECIALTY TOOLS

Dent Fix Equipment  
1611 W. 135th • Gardena • CA  
800.523.1751  
info@dentfix.com  
www.dentfix.com